



Barovier & Toso

VENEZIA 1295

# INTERIORS





Barovier&Toso

VENEZIA 1295

**INTERIORS**





Vivere Barovier&Toso è sempre un'emozione, originata da settecento anni di storia sapientemente valorizzati in un processo di reinvenzione continua. Una storia affascinante, che prende avvio nel 1295 – quando un Barovier appare per la prima volta nei documenti storici dell'epoca che parlano della “materia vetro” – e che prosegue di generazione in generazione, superando indenne guerre, epoche, stili e gusti con una capacità di trasformazione e rinnovamento che solo passione e dedizione possono dare.

Experiencing Barovier&Toso is a continuous emotion which originates from seven hundred years of history that are skilfully nurtured in an ongoing reinventive process.

This charming story started in 1295 – the first time a Barovier appeared in the historical documents of the period which discussed “glass material” – and has continued from generation to generation, overcoming wars, eras, styles and tastes unscathed, with an ability for transformation and innovation that only passion and dedication can instil.



Angelo il Grande e il suo “cristallo”,

Ercole e le sue invenzioni e il suo design: separati da cinque secoli eppure così simili nella loro genialità e nella sensibilità, per cogliere il cambiamento che le loro rispettive epoche imponeva per tramandare un'arte fino ai giorni nostri.

Barovier&Toso ancora oggi interpreta il gusto dei tempi, coniugando la tradizione vetraria degli avi con tendenze e innovazioni negli stili e nelle tecnologie, e arricchisce la vita e le emozioni di

Angelo the Great and his “crystal”,

Ercole and his inventions and design:

separated by five centuries, and yet so similar in their brilliance and sensitivity as to understand the change that their respective periods imposed in order to pass on an art to this day and age.

Even today, Barovier&Toso interprets the tastes of the period by combining the glass tradition of its forefathers with trends and innovations in style and technology.

chi sa cogliere le sfumature del “bello”.

Per meglio raccontare queste emozioni, abbiamo raccolto in un libro le suggestioni che un lampadario Barovier&Toso accende quando viene inserito nel contesto di un'abitazione: tre stili abitativi diversi, molte case ma uno stesso ed inimitabile stile Barovier&Toso.

A dimostrazione della versatilità di una creazione che è fatta per essere ammirata, non solo per fare luce.

In doing so, it enhances the life and the emotions of those who know how to capture the nuances of “beauty”.

To better describe these emotions, we have gathered in a book the splendour that a Barovier&Toso chandelier ignites when it's included in a home: three diverse residential styles.

Many homes, but the same inimitable Barovier&Toso style.

A demonstration of the versatility of a creation which is made to be admired, and not just to give light.



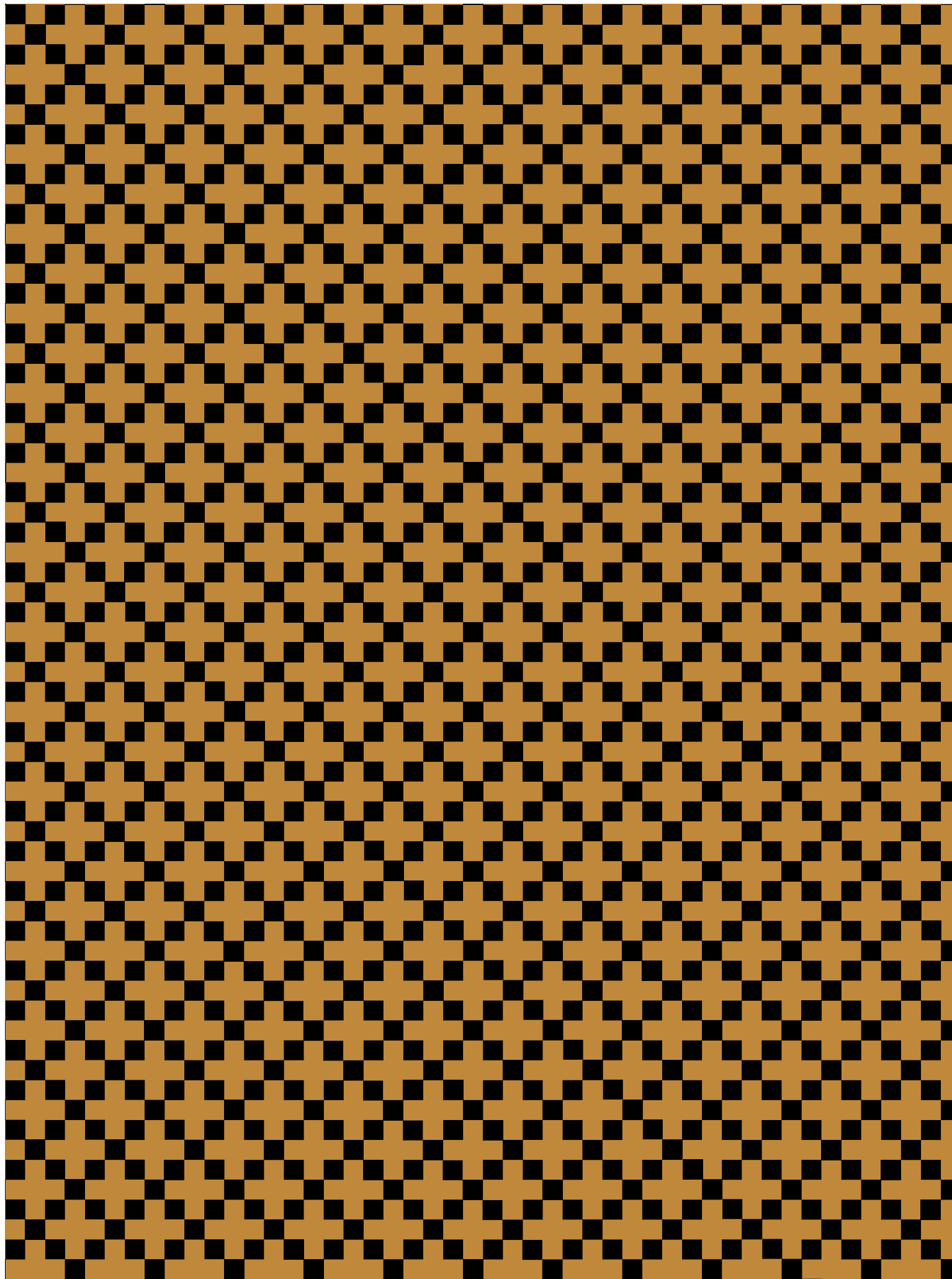









Angel  
AI Design 2015













Pandora  
Barovier&Toso 2013











Venezia 1295  
Barovier&Toso 2018



























Taif  
Barovier&Toso 1980

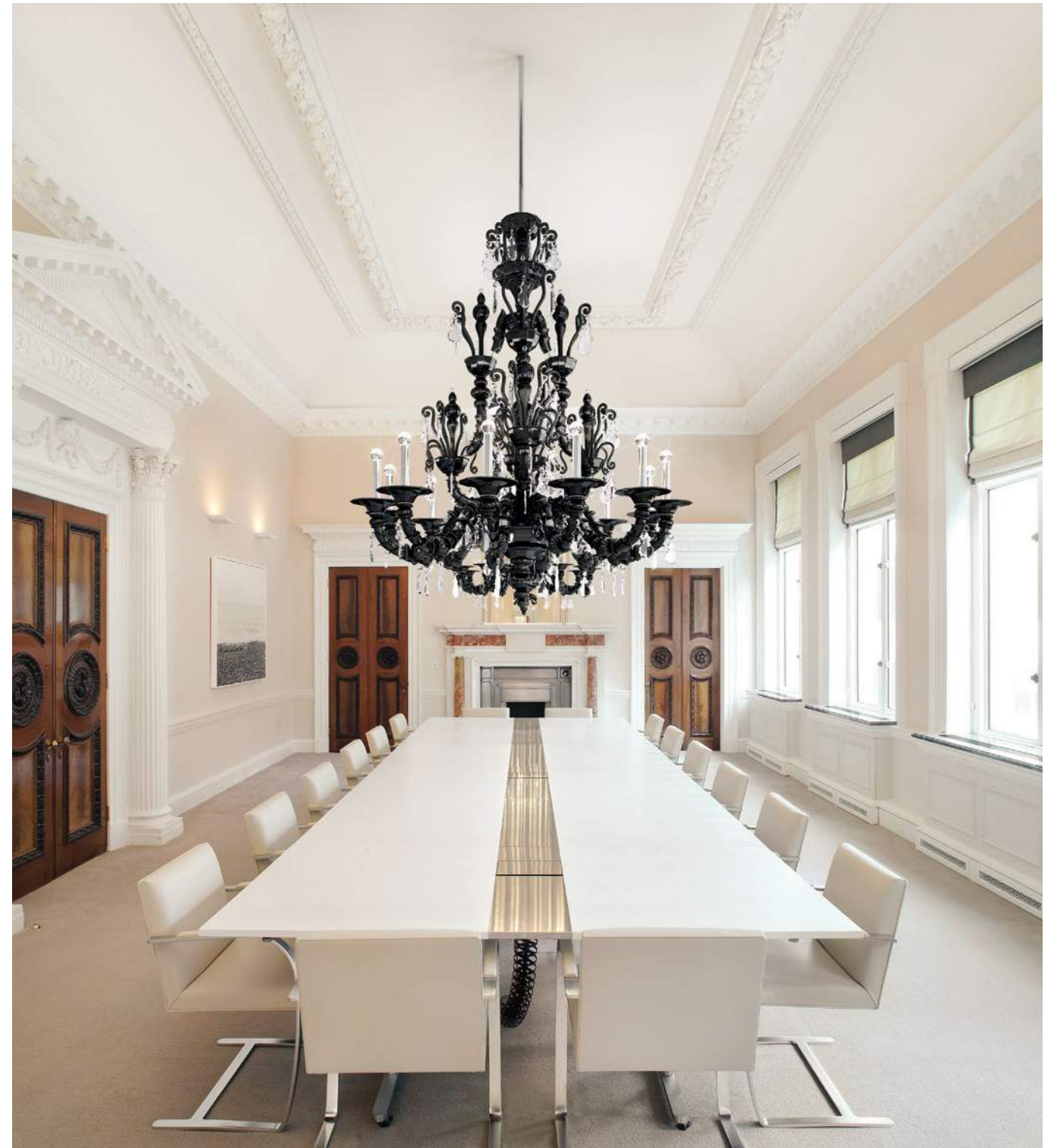













Exagon  
Barovier&Toso 2010















Samurai  
Angelo Barovier 1966/2008











MODERN  
HOUSE









Rosati  
Barovier&Toso 2018





Perseus  
Marcel Wanders 2015































Florian  
Barovier&Toso 2018















Quadri  
Barovier&Toso 2018





Optical  
Barovier&Toso 2007



Amsterdam  
Barovier&Toso 2006











Samurai  
Barovier&Toso 1966/2008

Alexandria  
Barovier&Toso 2008

Twins  
Barovier&Toso 2013









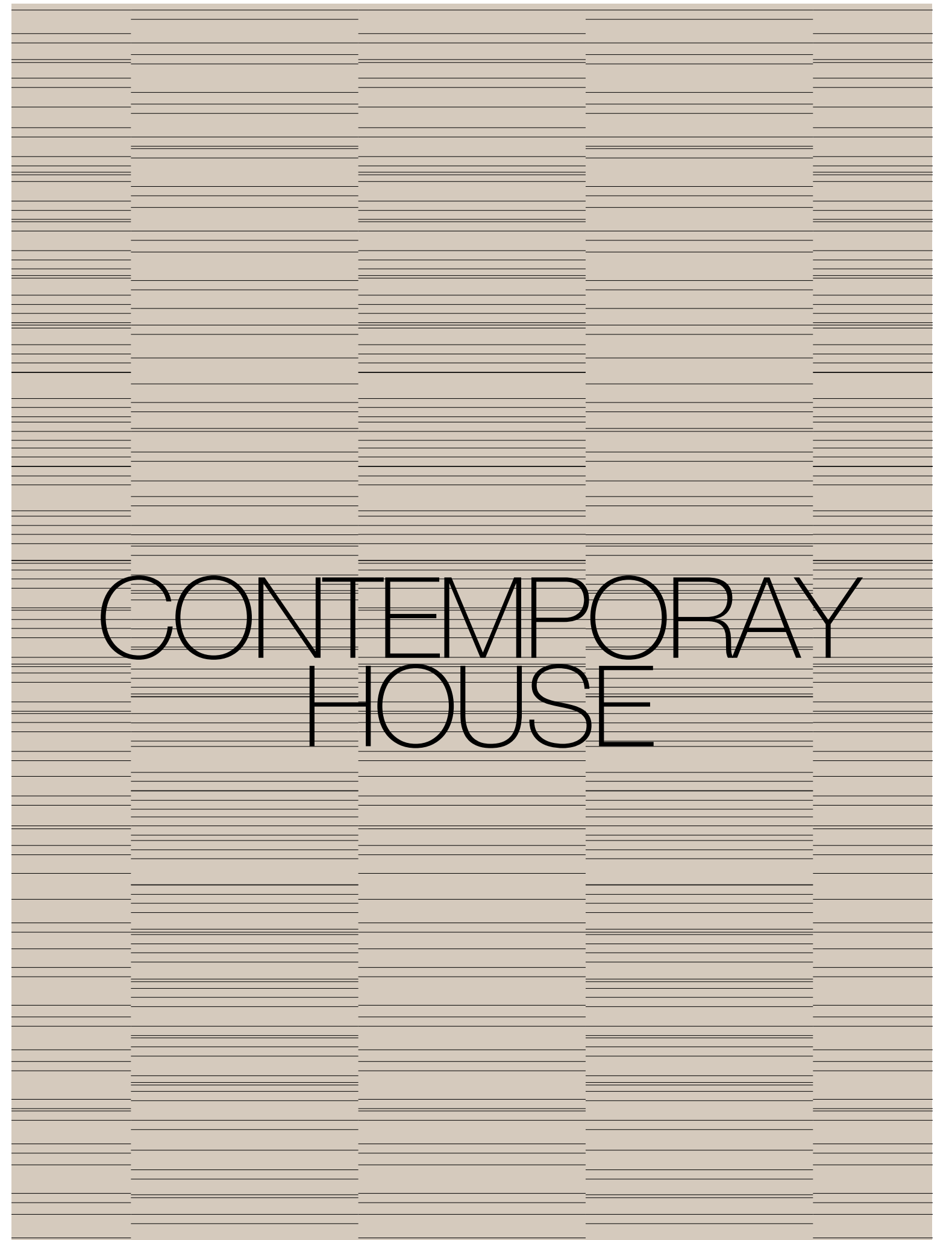
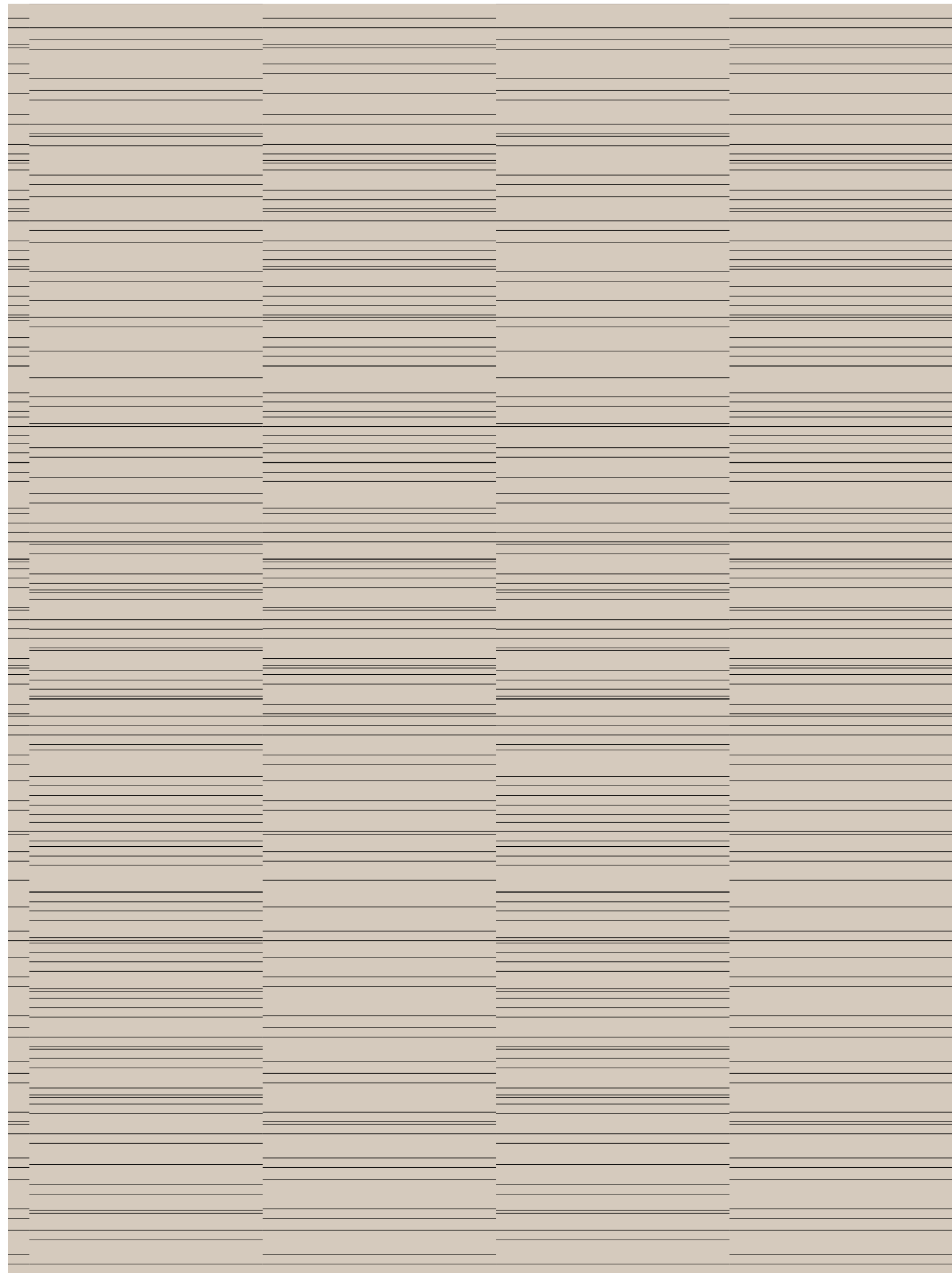









New Eden  
Daniela Puppa  
Francesca Martelli  
2017





















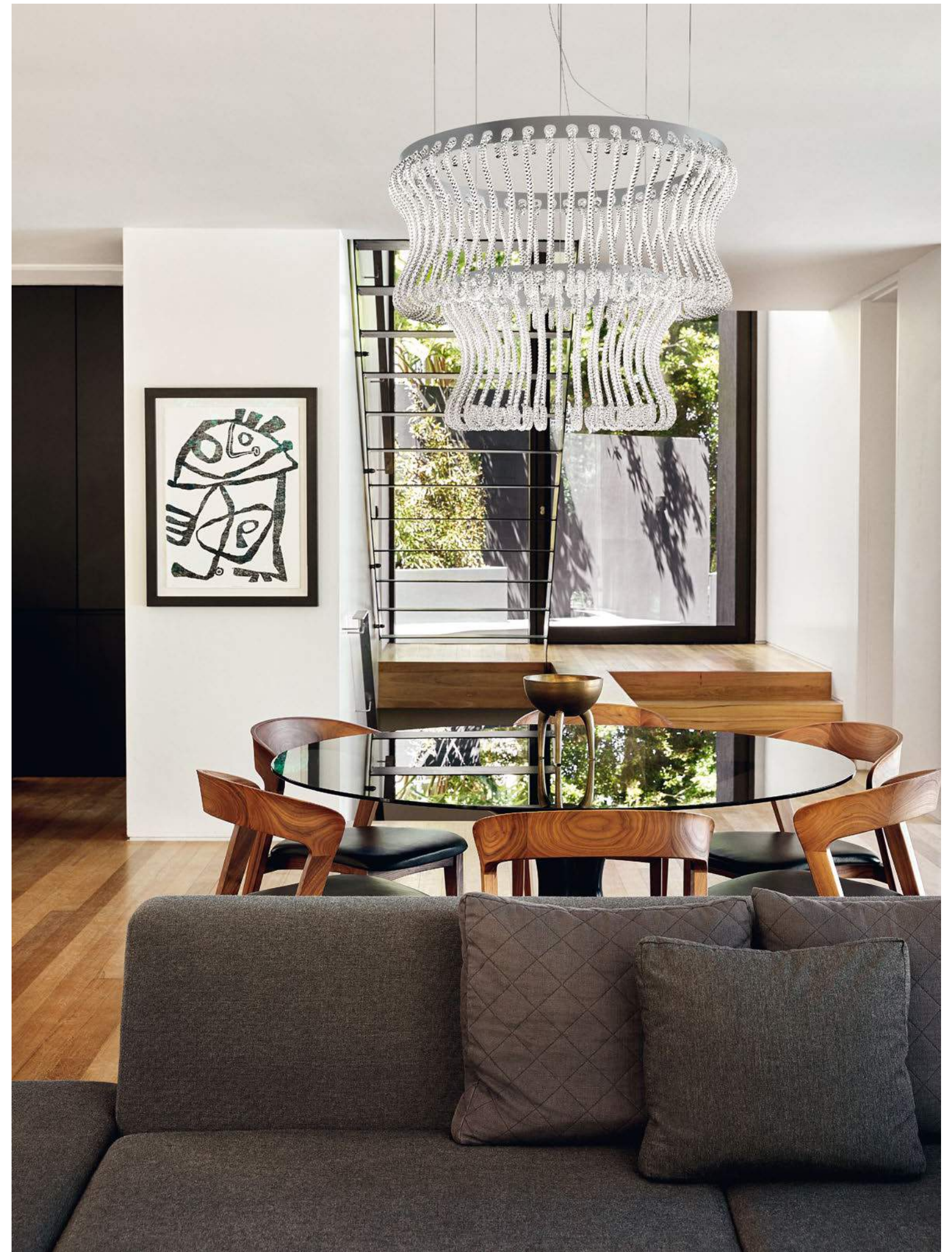





Hermitage  
Barovier&Toso 2019































Marrakech  
Barovier&Toso 2019

Camparino  
Barovier&Toso 2018







Palmyra  
Fabio Calvi Paolo Brambilla 2015



















Taif Barovier&Toso 1980

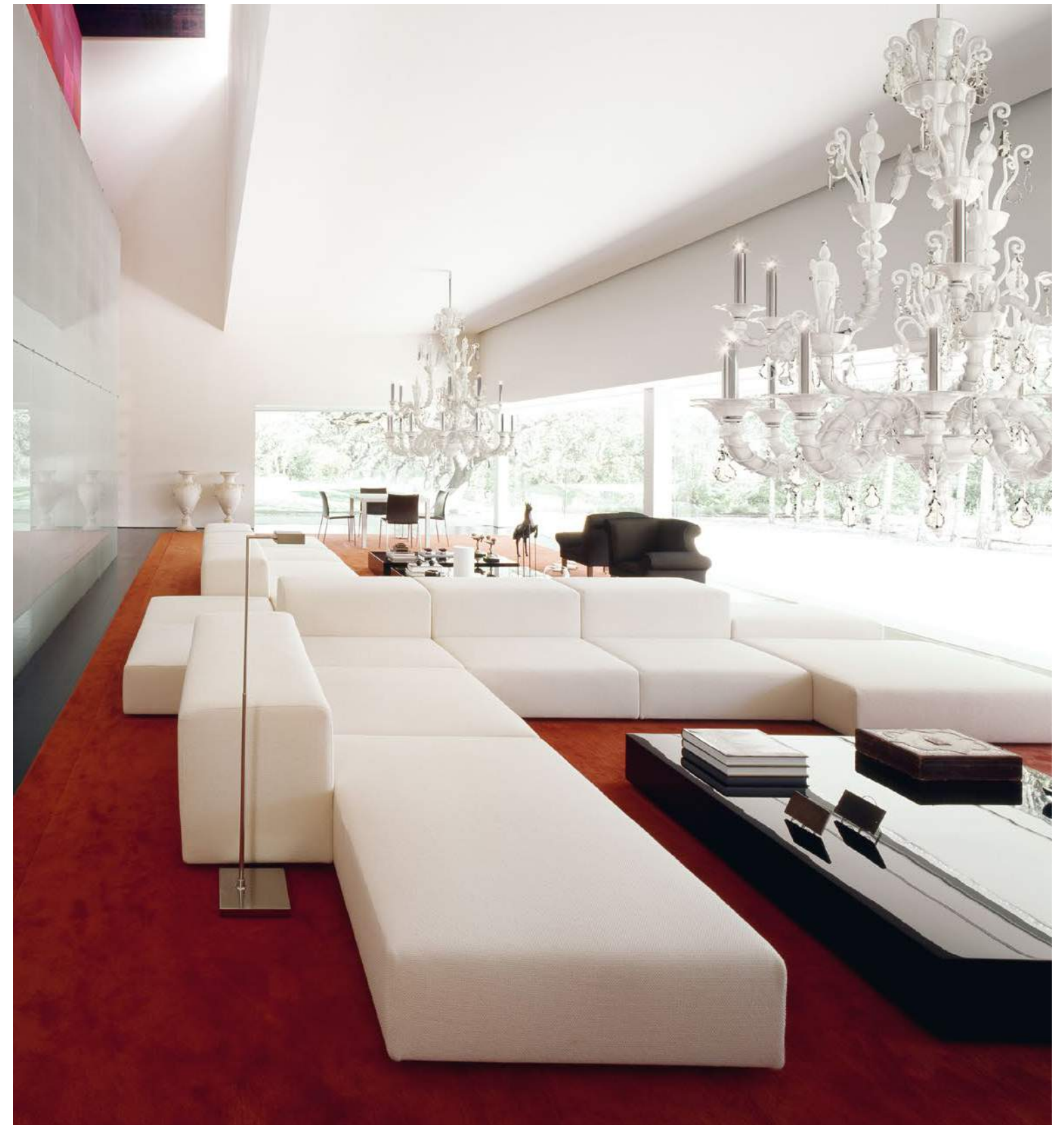













Torpedo Amsterdam  
Barovier&Toso 2010

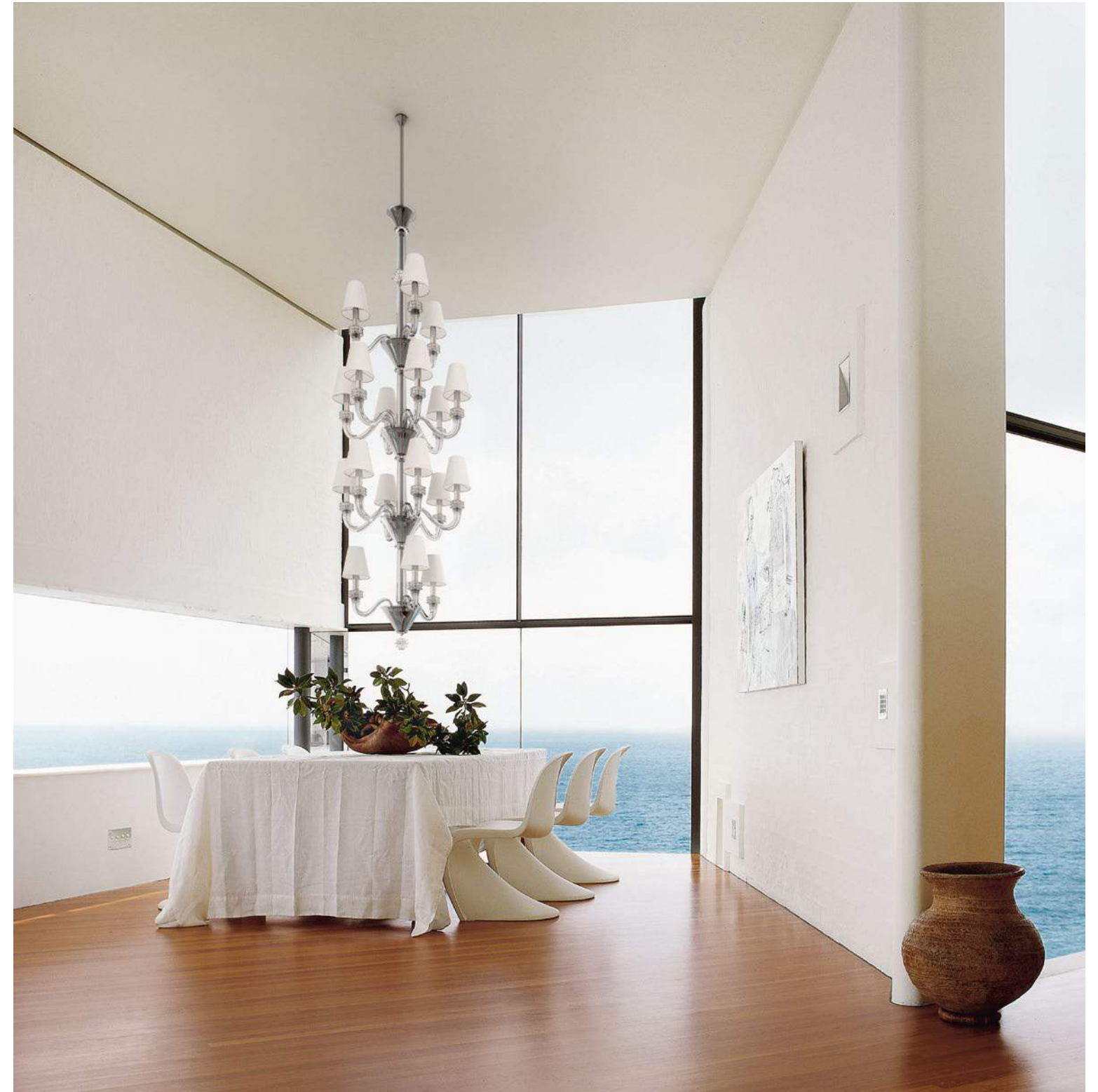







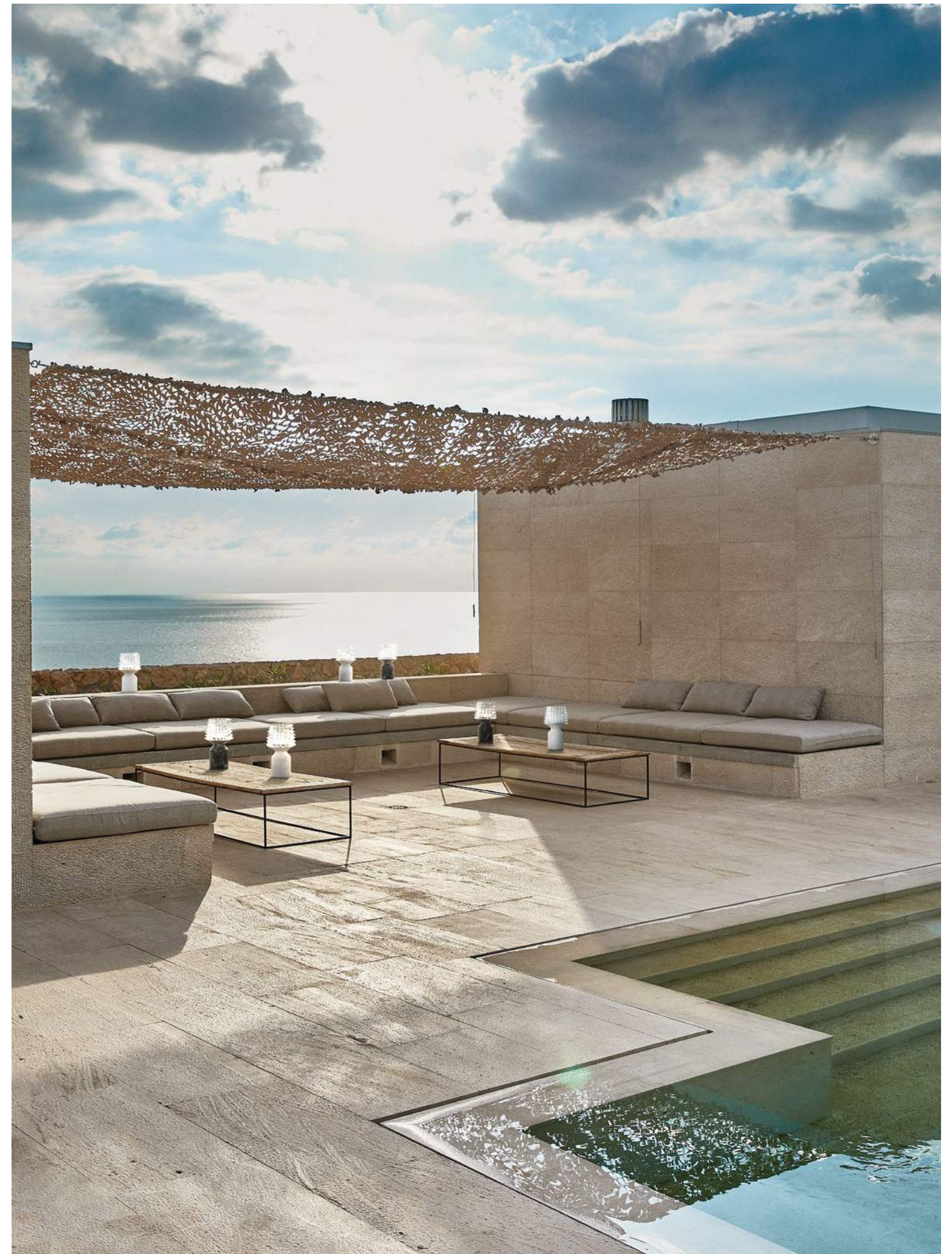







Alumina  
Alessandro Piva 2016

Camparino  
Barovier&Toso 2018















Bissa Boba  
Angelo Barovier 1992/2004

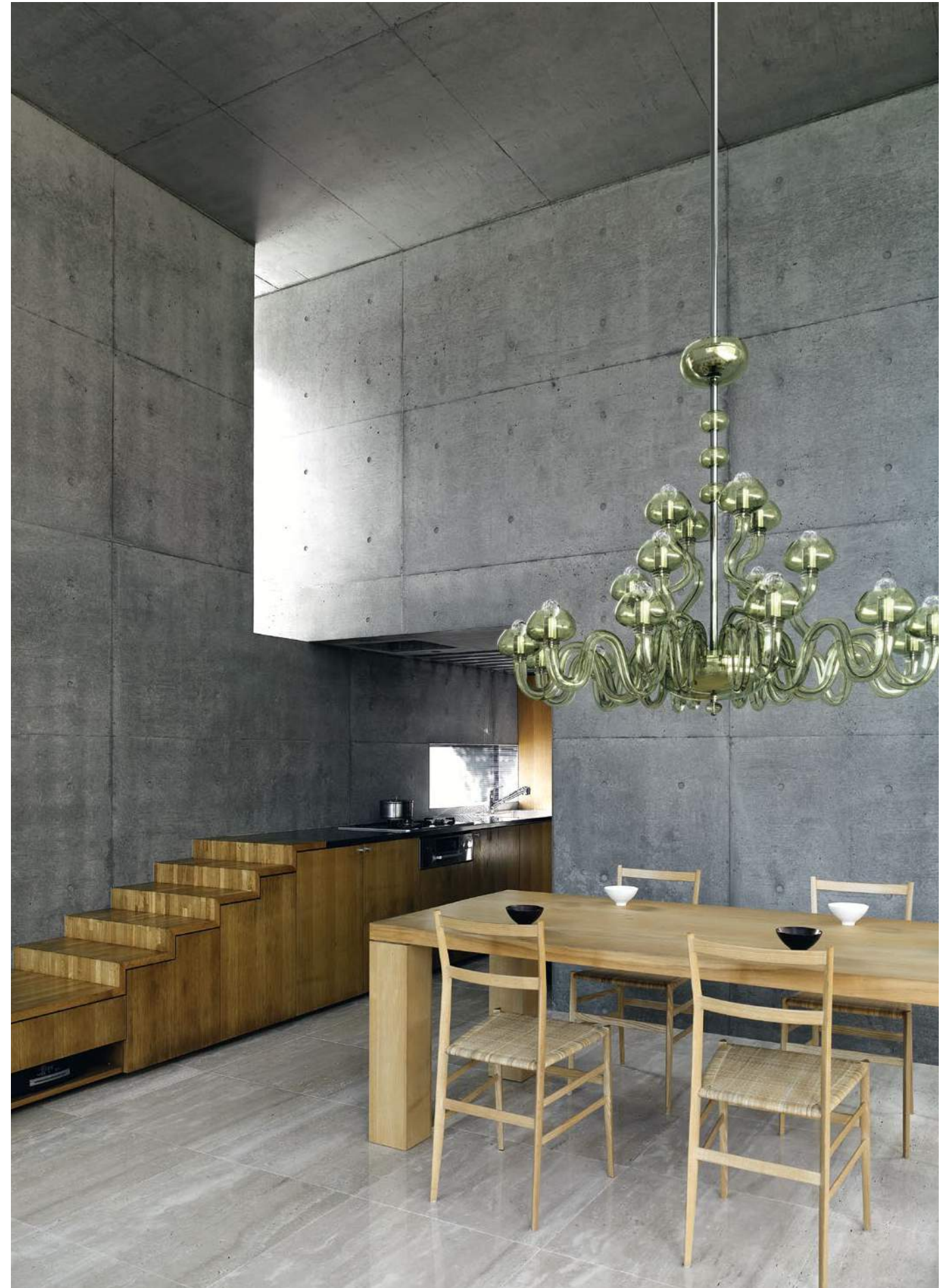



















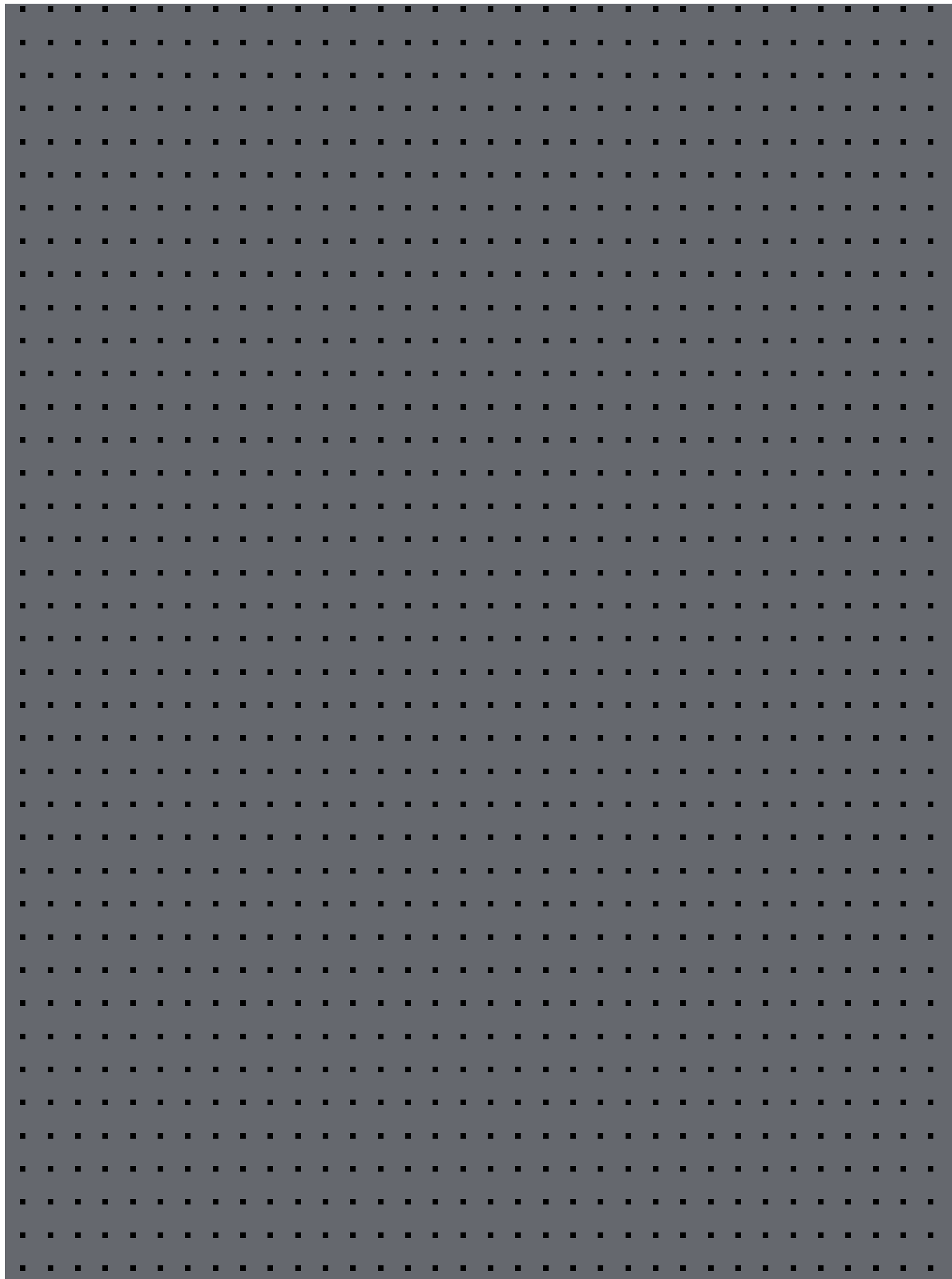

# PUBLIC SPACES











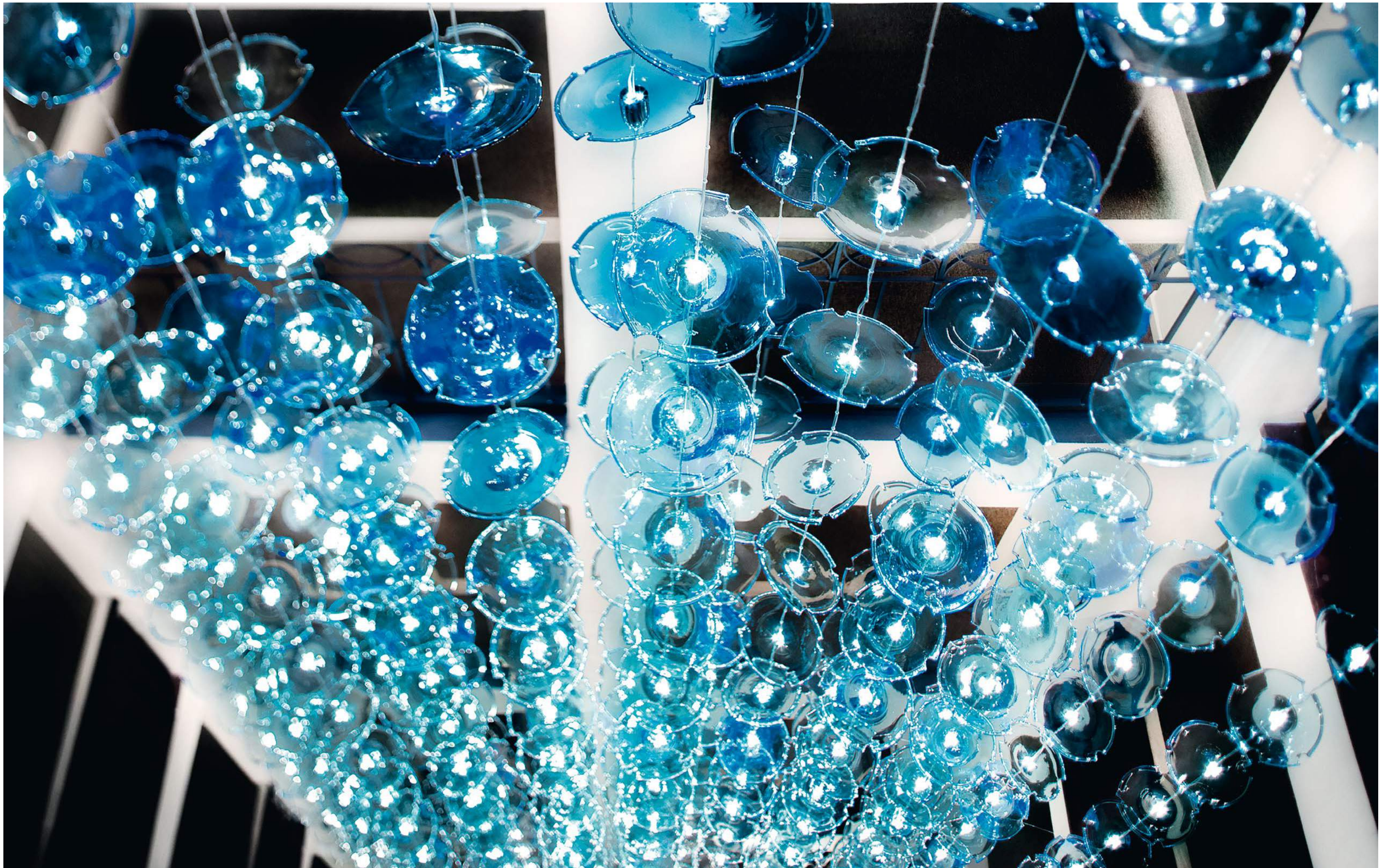











Taif  
Barovier&Toso 1980

Saint Germain  
Giorgia Brusemini 2008

















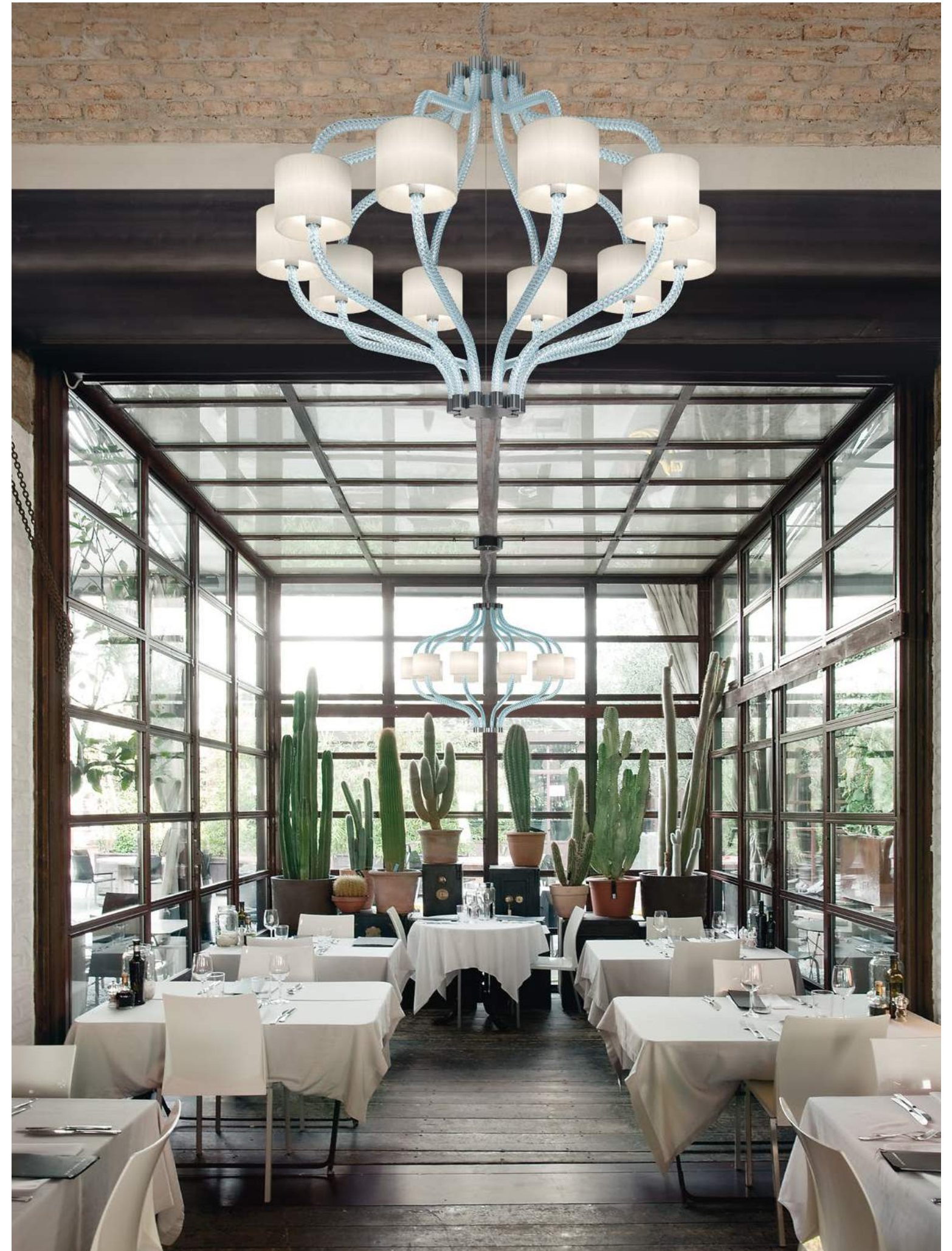



















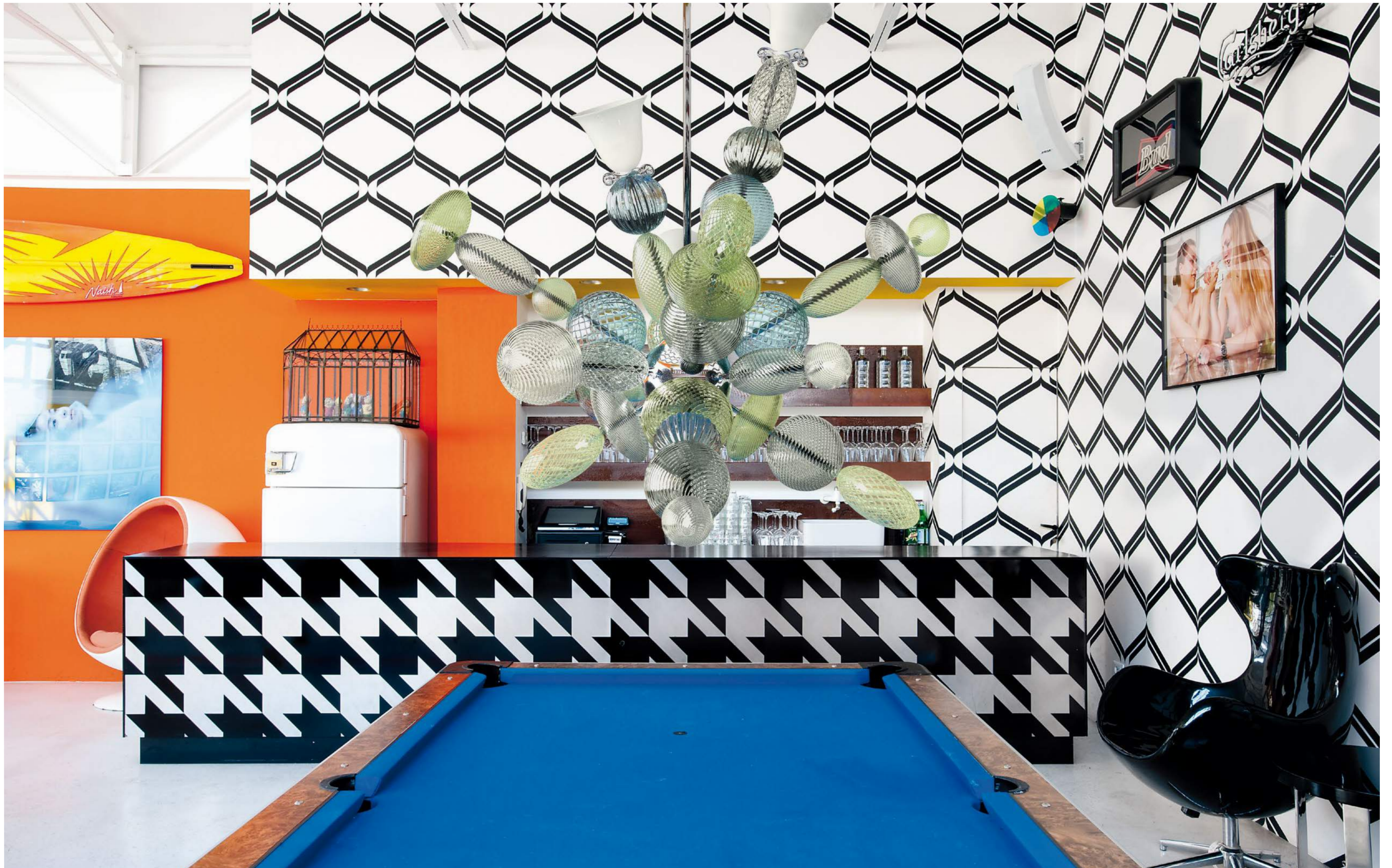







## References



**Izmir**  
pag 156-157

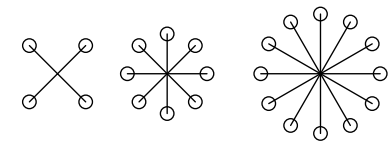
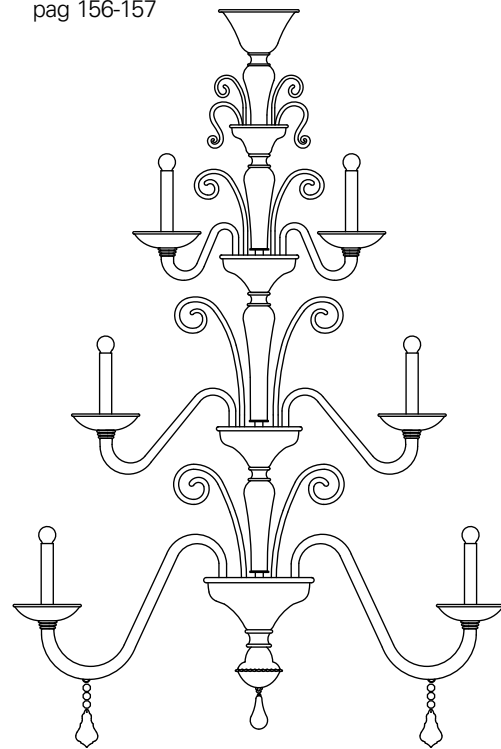

**Taif**  
pag 32-33

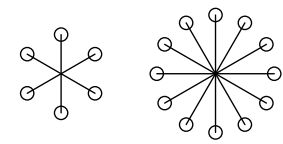
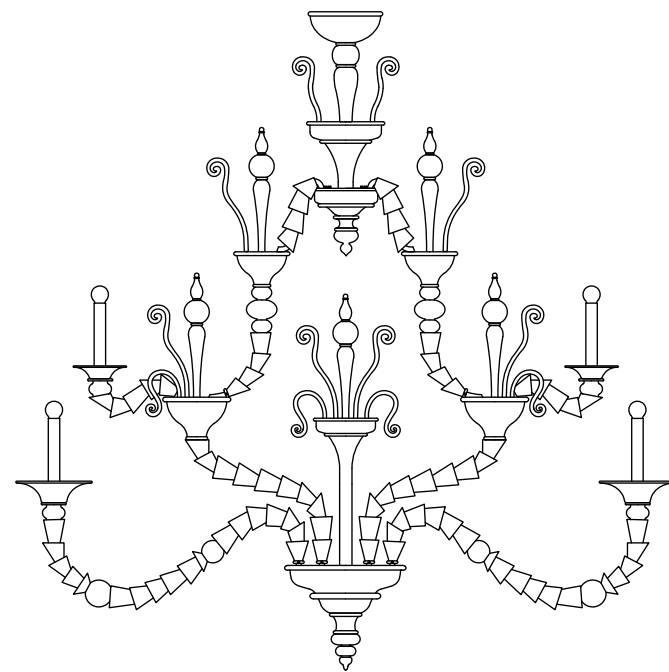

**Windsor**  
pag 112-113

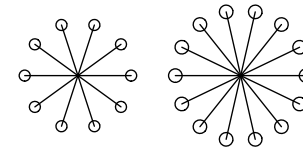
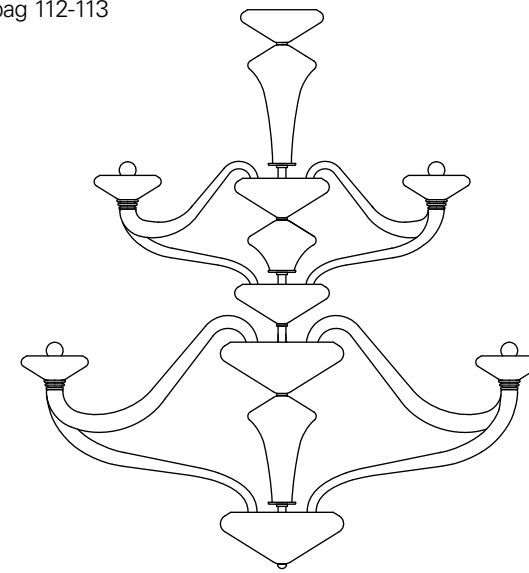

**Bissa Boba**  
pag 149-151

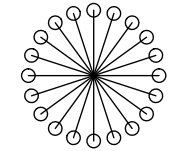
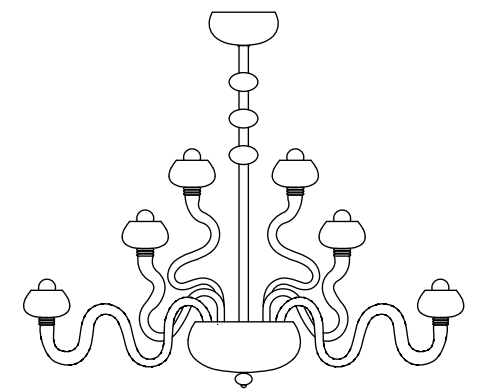

**Saint Germain**  
pag 14-15

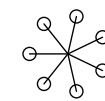
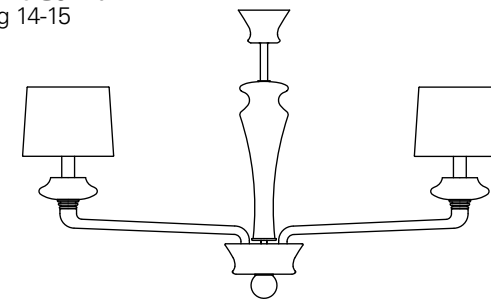

**Palladiano**  
pag 152-155

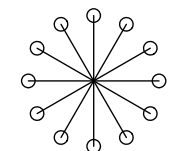
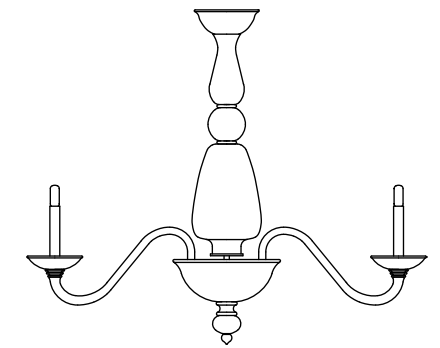

**Tangeri**  
pag 30-31

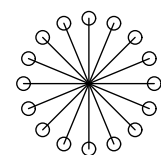
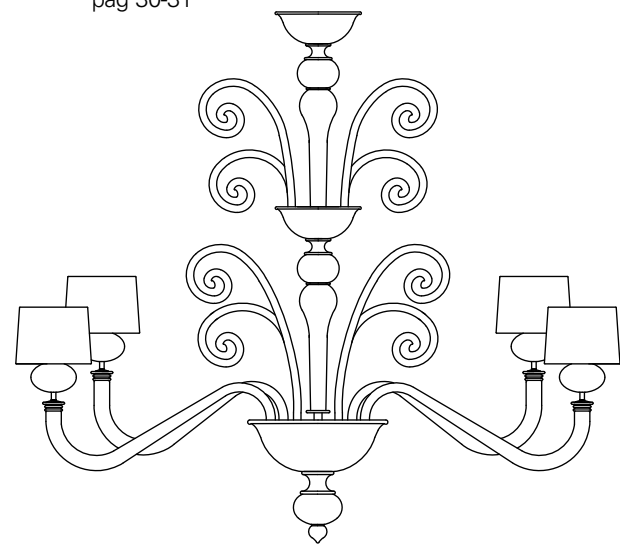

**Venezia 1295**  
pag 20-21

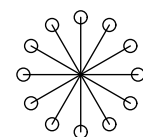
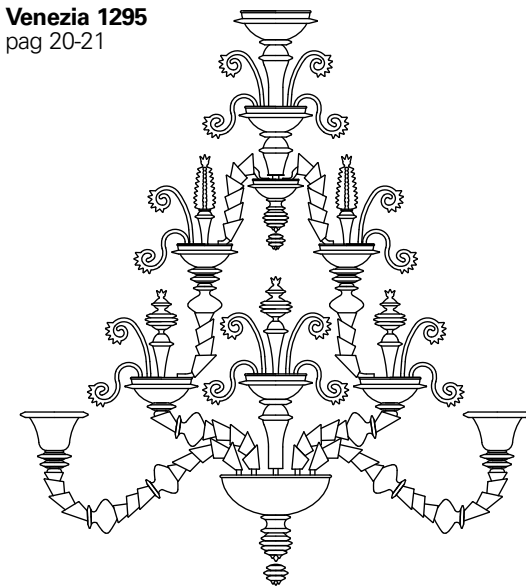

**Adonis**  
pag 22-23

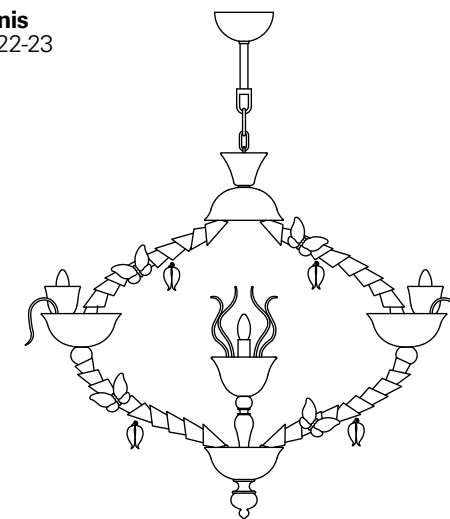

**Fauve**  
pag 42-45

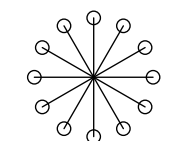
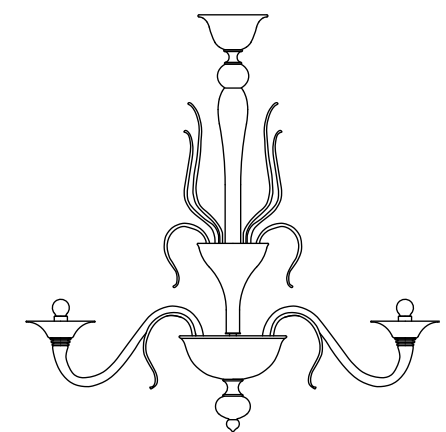



**Rotterdam**  
pag 66-68

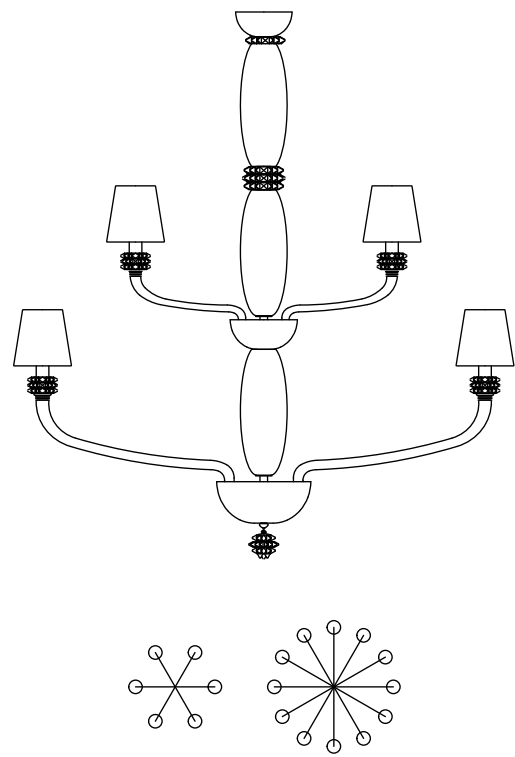

**Rosati**  
pag 52-54

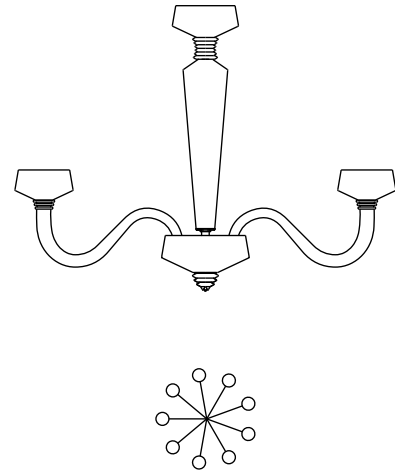

**Torpedo Taif**  
pag 96-97

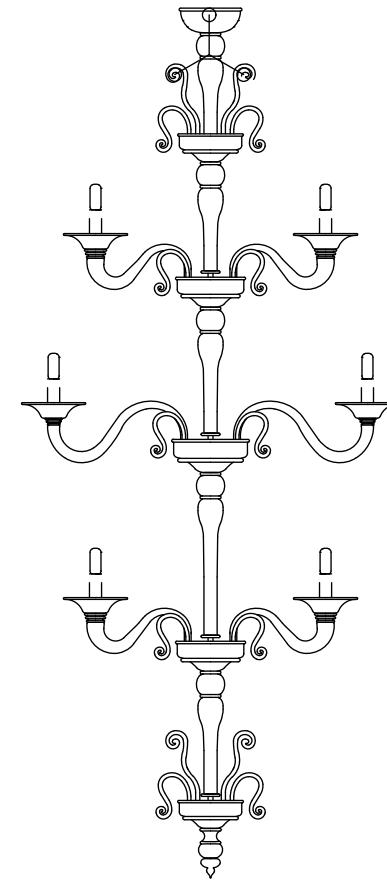

**Torpedo Amsterdam**  
pag 134-135

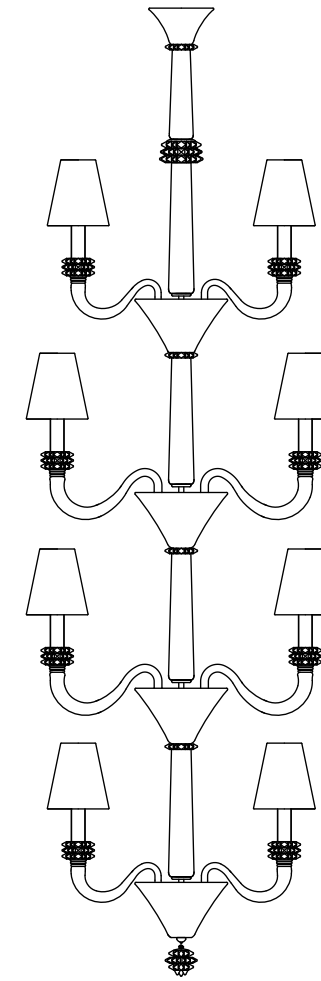

**Colimaçon**  
pag 69

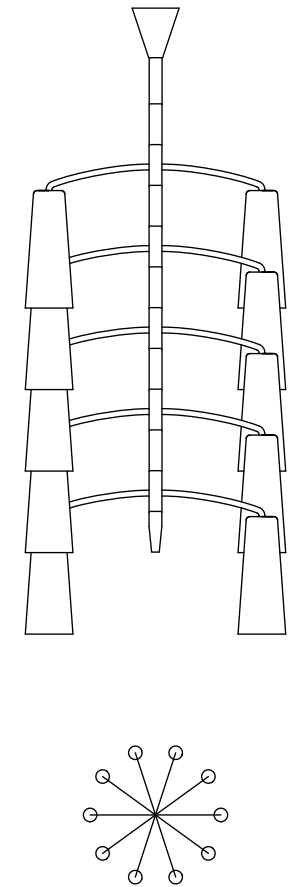

**Alexandria**  
pag 28-29, 82

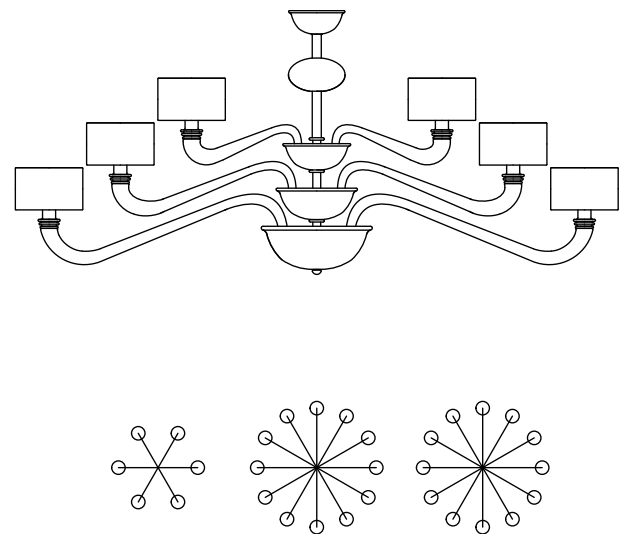

**Nevada**  
pag 63-65

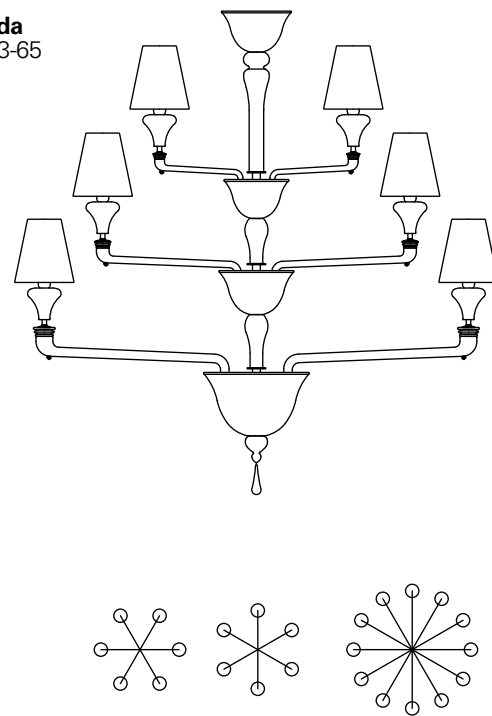

**Amsterdam**  
pag 78-81

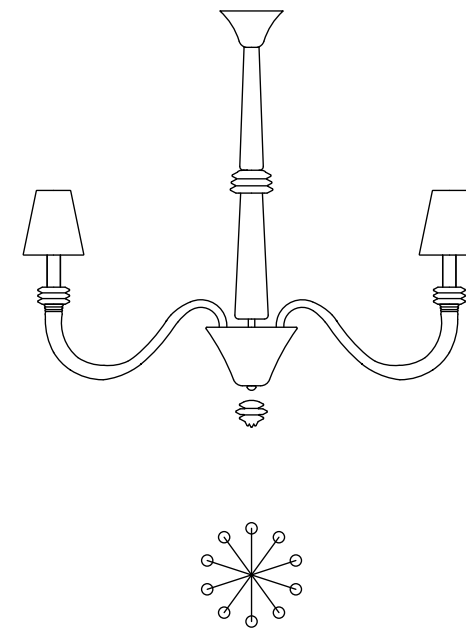

**Colimaçon**  
pag 136-137

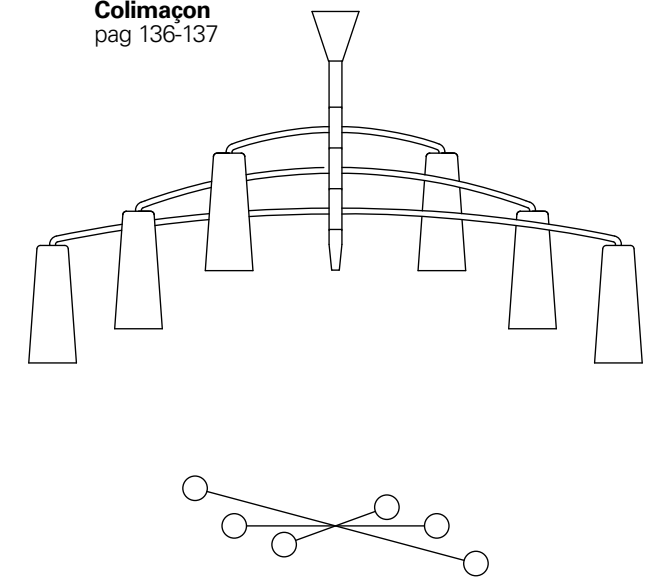



**Florian**  
pag 70-71

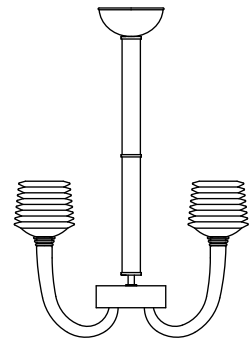
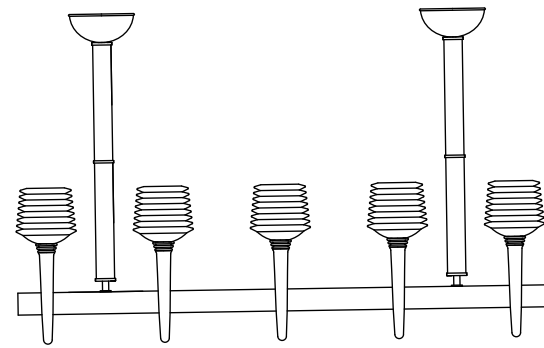

**Quadri**  
pag 22-23, 110-111

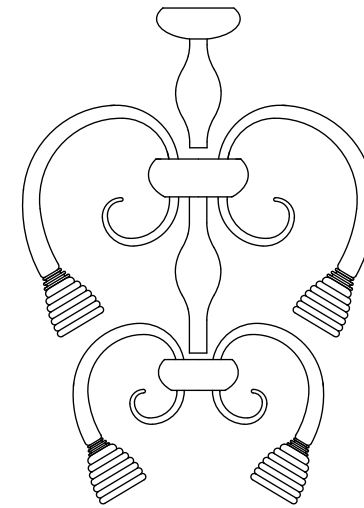

**Quadri**  
pag 76-77

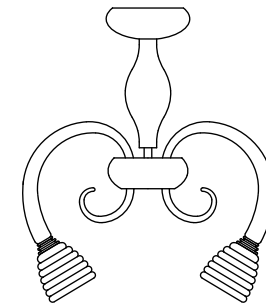

**Domo Nevada**  
pag 144-147

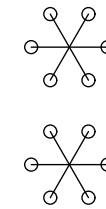
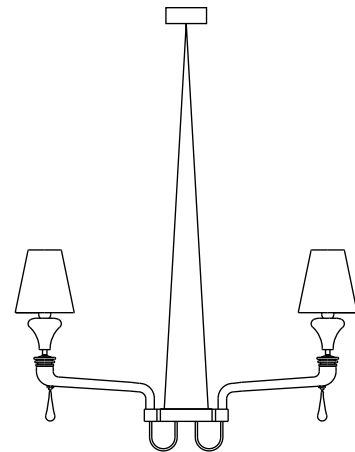
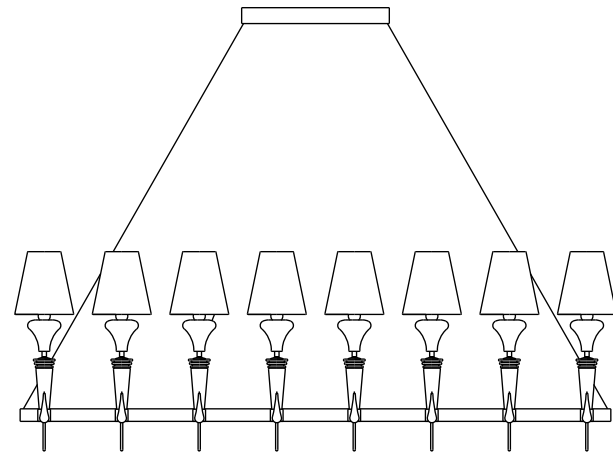

**Alumina**  
pag 140-143

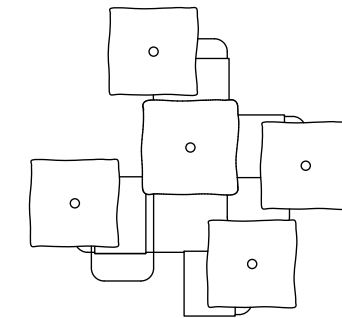

**Matrioska**  
pag 130-133

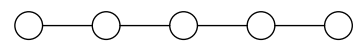
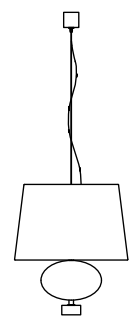
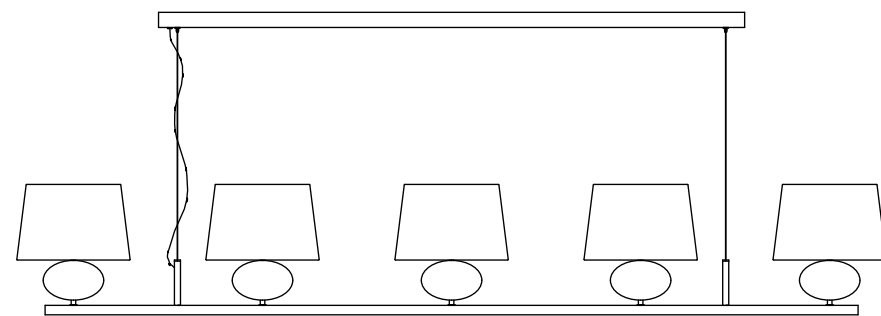

**Shadow Taif**  
pag 35-37, 48-49

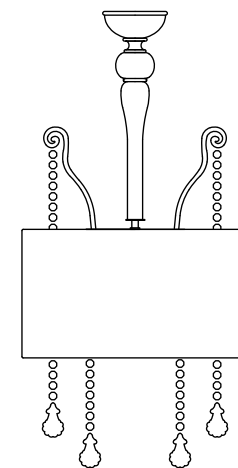

**Pandora**  
pag 16-17, 168-170

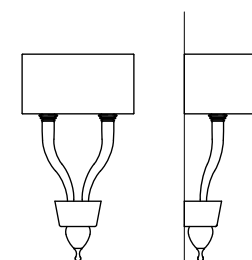
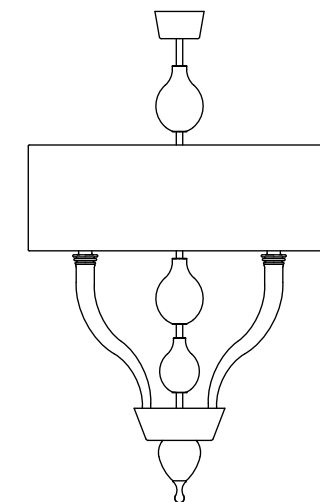

**Twins**  
pag 106-108

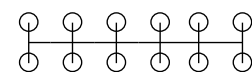
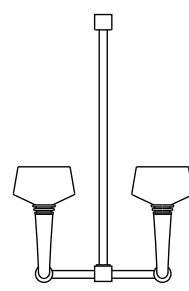
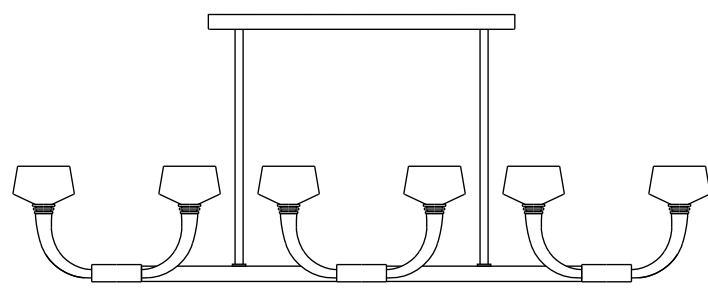



**Tuileries**  
pag 114-115

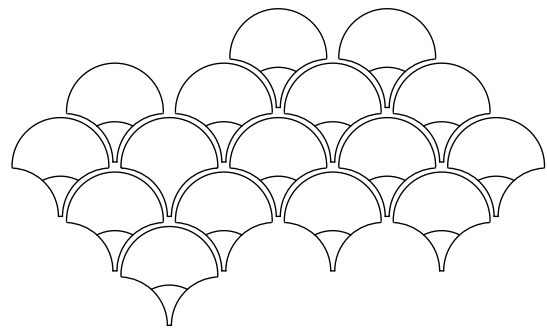

**Marrakech**  
pag 93-94, 118-119, 122-125

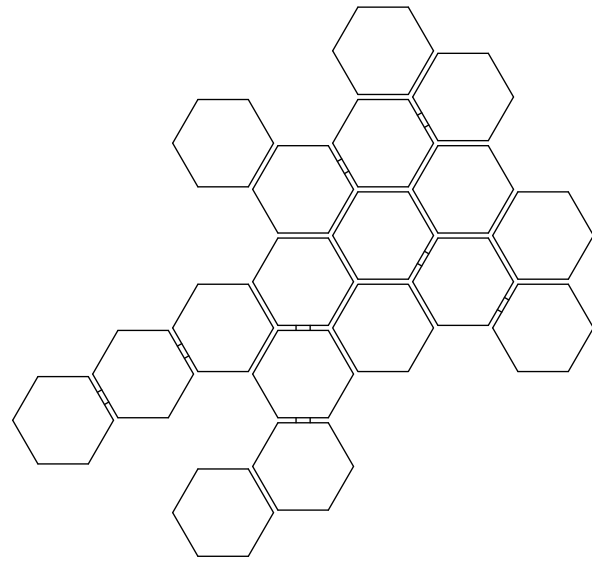

**Hanami**  
pag 116-117

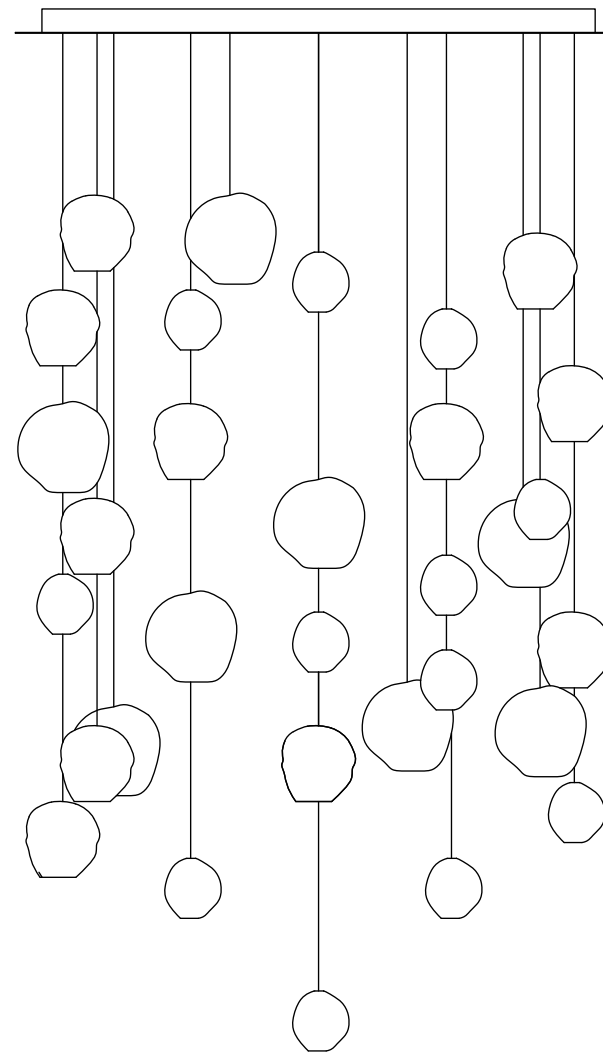

**Spinn**  
pag 160-163, 172-175

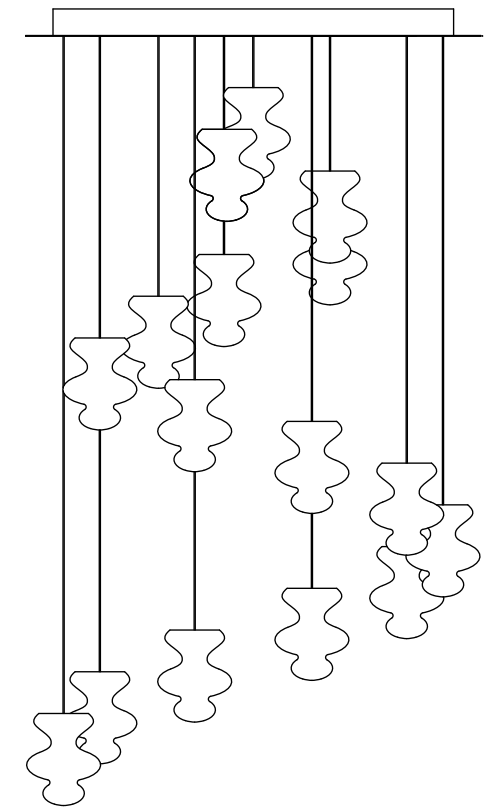

**Trim**  
pag 72-74

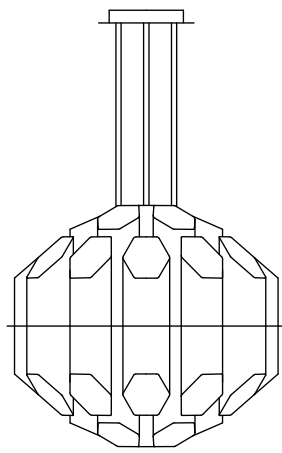

**Trim**  
pag 176-177

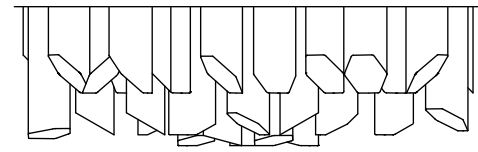

**Optical**  
pag 78

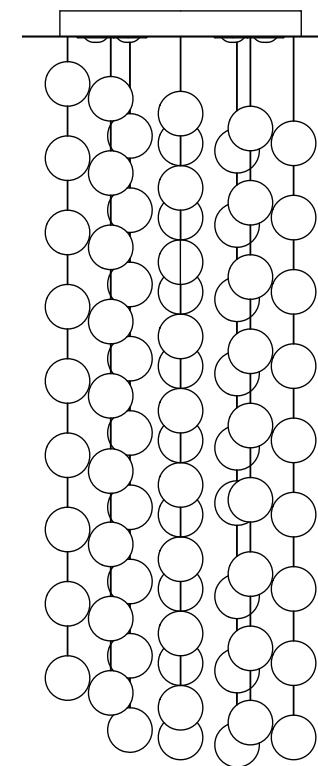

**Hermitage**  
pag 102-105

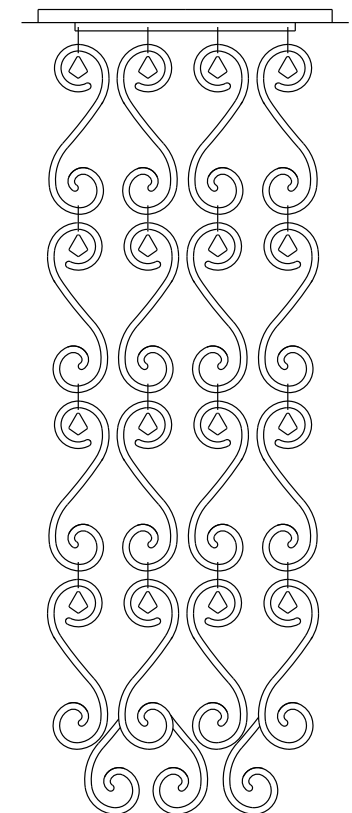

**New eden**  
pag 90-91

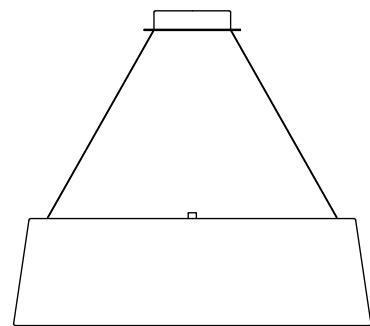

**Exagon**  
pag 38-41, 84-85, 164-167

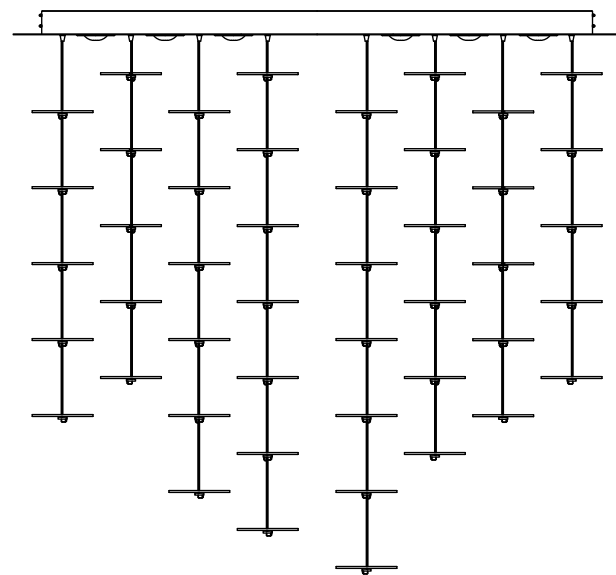



**Crown**  
pag 98-101

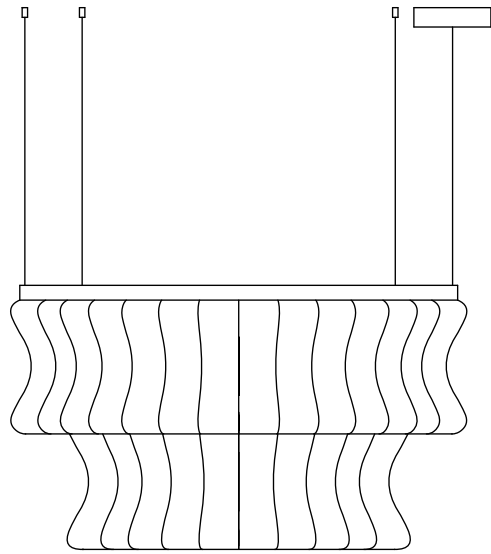

**Palmyra**  
pag 120-121, 186-187

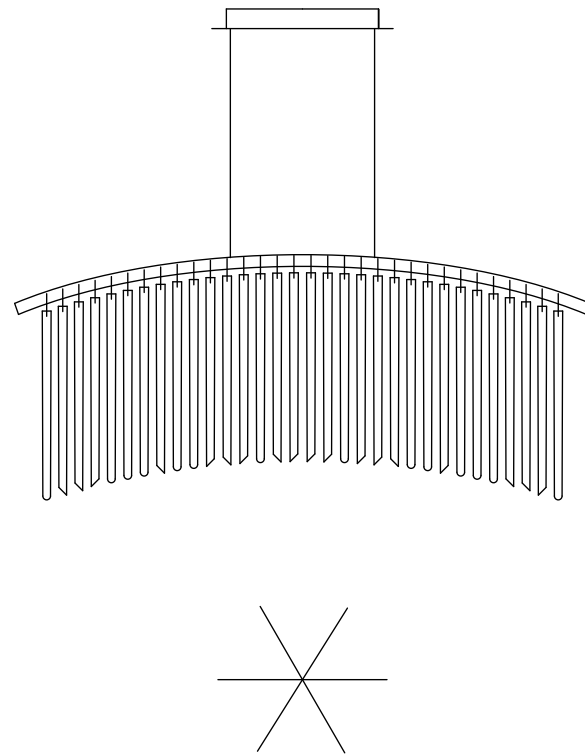

**Lincoln**  
pag 184-185

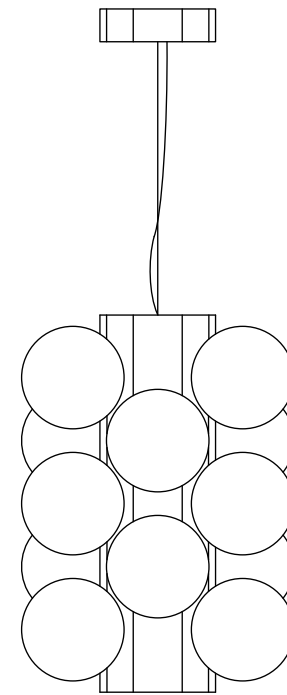

**Hastings**  
pag 179-181

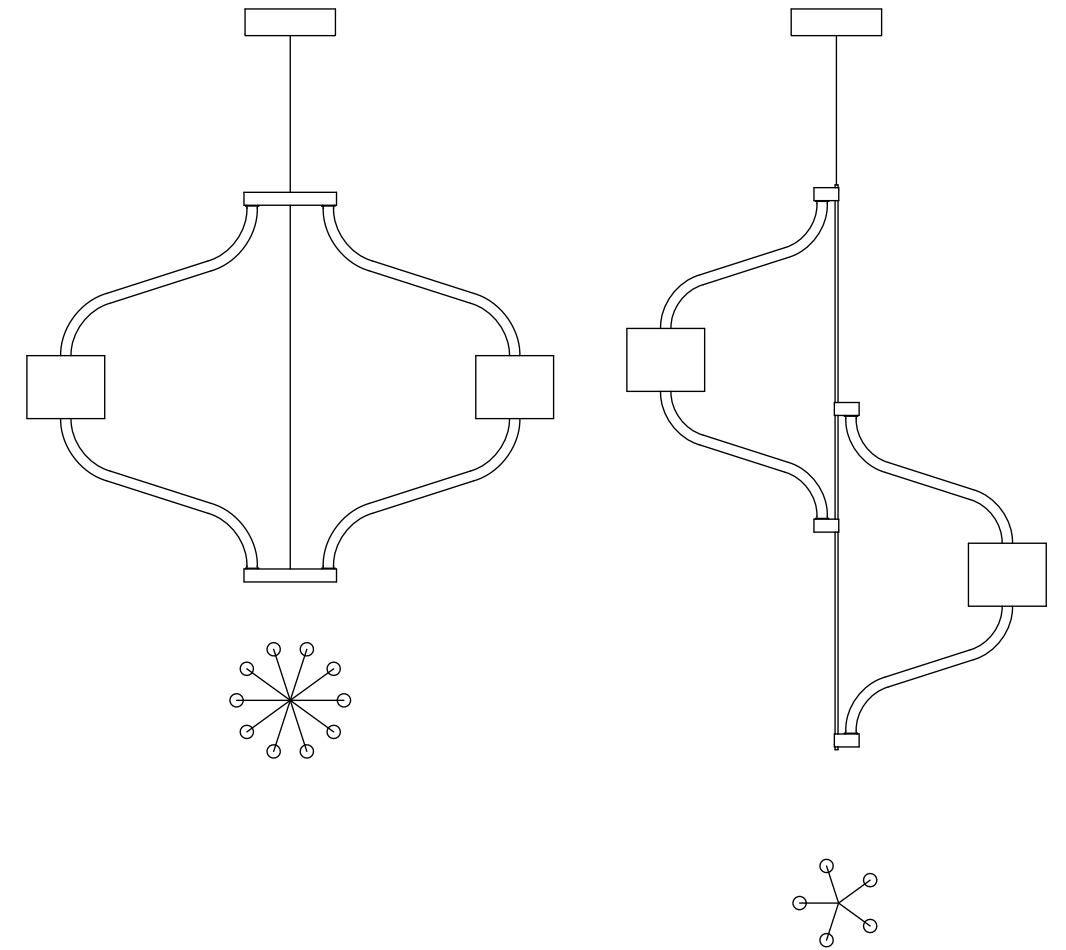

**Perseus**  
pag 18-19, 56-57, 188-191

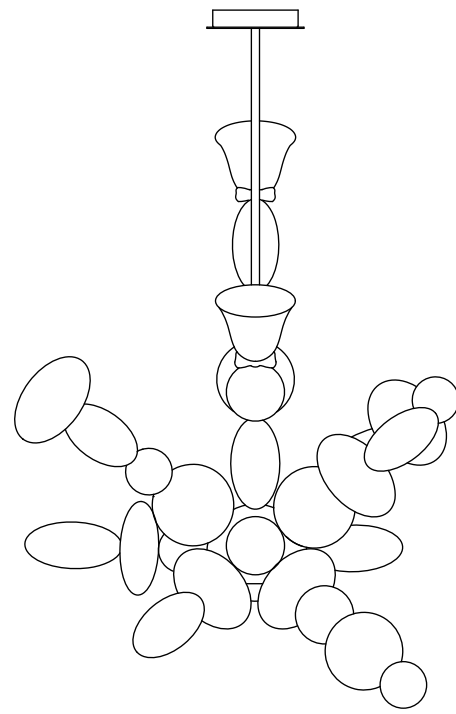

**Angel**  
pag 8-10

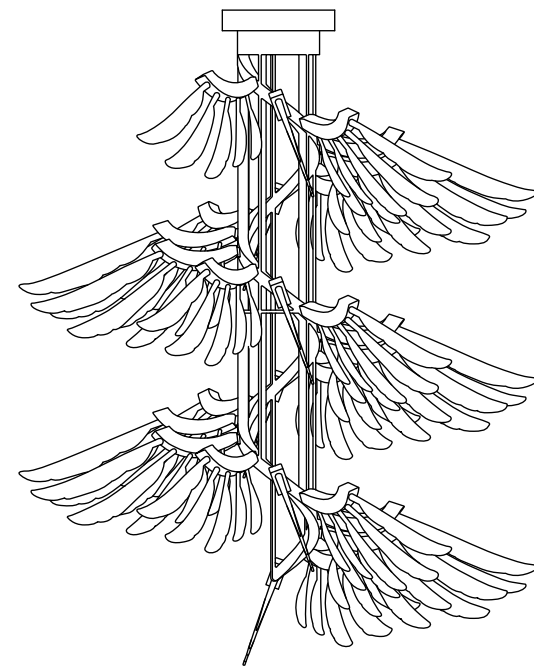

**Lincoln**  
pag 182-183

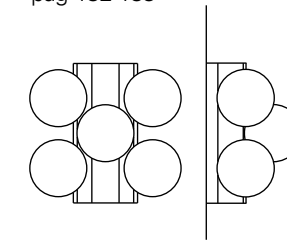

**Samurai**  
pag 46-47, 83

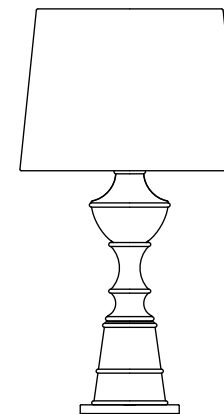

**Saint Germain**  
pag 14-15, 171

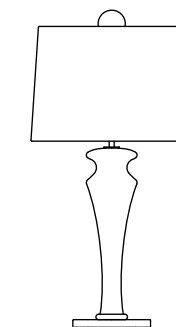

**Camparino**  
pag 118-119, 138-143

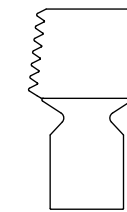

**Pigalle**  
pag 88-89

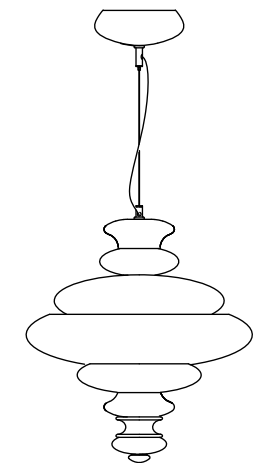

**Robin**  
pag 56-61

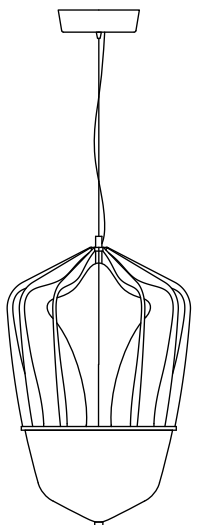



#### **Concept and graphic**

Marco Strina

#### **Project manager**

Massimo Bovi

#### **Photo credit**

Filippo Bamberghi 116, 117

Edmund Barr 164, 165, 167, 174, 170, 171

Gianni Basso /Vega MG 84, 85, 179, 180, 181, 188, 189, 191

Denise Bonenti /Vega MG 28, 29

Franco Chimenti 42, 43, 44, 45, 152, 153, 154, 155

Greg Cox/Bureaux agency/Living Inside 70, 71, 76, 77,93, 94, 98, 99, 101, 102, 104, 105, 110, 111, 114, 115, 118, 119, 122, 123, 125, 138, 139, 176, 177

Catalin Cucu 168, 169

Gianni Franchellucci / Living Inside 8, 9, 10, 12, 13, 14, 15, 16, 17, 18, 19, 59, 60, 61, 88, 89, 96, 97, 106, 107, 108,120, 121

Chris Gascogne /VIEW 182, 183

Tessa Jol/Taverne agency/Living Inside 22, 23

Jansje Klazinga/Taverne agency /Living Inside 76, 77

Natalie Krag / Living Inside 140, 141, 143

Gaëlle Le Boulicat 56, 57, 63, 64, 65, 112, 113, 134, 135, 136, 137, 144, 145, 146, 147

Davide Lovatti /Vega MG 66, 67, 68, 69

Davide Lovatti / Living Inside 20, 21, 52, 53, 54, 72, 73, 74, 90, 91

Lorenzo Nencioni /Vega MG 35, 36, 37, 148, 149, 150, 151

James Newton /VIEW 186, 187

Eugeni Pons /Vega MG 126, 127, 128, 129, 130, 131, 132, 133

Giorgio Possenti /Vega MG 156, 157

Chris White 78, 79, 80, 81, 82, 83

National Trust 184, 185

Ego 24, 25, 26, 27, 30, 31, 38, 39, 40, 41, 46, 47, 78, 49

Turri 160, 161, 162, 163

Bulgari Hotels & Resorts 172, 173, 174, 175

#### **Compositing 3D**

Reality Studio, Modena – [www.realitystudio.it](http://www.realitystudio.it)

8, 9, 10, 11, 12, 13, 14, 15, 16, 17, 18, 19, 20, 21, 22, 23, 24, 25, 26, 27, 28, 29, 46, 47, 52, 53, 54, 56, 57, 59, 60, 61, 63, 64, 65, 66, 67, 68, 69, 70, 71, 72, 73, 74, 76, 77, 88, 89, 90, 91, 93, 94, 96, 97, 98, 99, 101, 102, 104, 105, 106, 107, 108, 110, 111, 112, 113, 114, 115, 116, 117, 118, 119, 120, 121, 122, 123, 125, 134, 135, 136, 137, 138, 139, 140, 141, 143, 144, 145, 146, 147, 149, 150, 151, 156, 160, 161, 162, 163, 176, 177, 179, 180, 181, 182, 183, 184, 185, 186, 187, 188, 189, 191

Bluemotion, Padova – [www.bluemotion.it](http://www.bluemotion.it) –

30, 31, 32, 33, 35, 36, 37, 38, 39, 40, 41, 42, 43, 44, 45, 48, 49, 84, 85, 126, 127, 128, 129, 130, 131, 132, 133, 152, 153, 154, 155

#### **Press Office**

Keywords Design Relations

#### **PrePress**

UpStudio Milano

#### **Print**

G&G srl

#### **Thanks to**

Ego – [www.egozeroventiquattro.it](http://www.egozeroventiquattro.it)

Turri – [www.turri.it](http://www.turri.it)

Hotel Stein, Salzburg - [www.hotelstein.at](http://www.hotelstein.at)

Bulgari Hotels & Resorts – [www.bulgarihotels.com](http://www.bulgarihotels.com)

#### **Barovier&Toso**

Vetriere Artistiche Riunite srl

Fondamenta Vetrai 28 30141 Murano Venezia

T (+39) 041739049 info@barovier.com

Showroom

Murano Palazzo Barovier&Toso, Fondamenta Manin 1/D

Milano, via Durini 5





---

[barovier.com](http://barovier.com)