



PINTINOX

PINTI INOX S.p.A.
Via Antonini, 87
25068 Sarezzo (BS) Italia
Tel. +39 030 89351
Fax +39 030 8935250
+39 030 8901163
www.pinti.it
pintinox@pinti.it

PINTI INOX GMBH
DEUTSCHLAND
Römerstraße 91
73066 Uhingen
Tel +49 07161 93343-0
Fax +49 07161 352789
www.pinti.de
muehlmeier@pinti.de
info@pinti.de

0001	Cucchiaio tavola - Table spoon - Cuiller de table - Tafelöffel - Cuchara mesa
0002	Forchetta tavola -Table fork - Fourchette de table - Tafelgabel - Tenedor mesa
0003	Colt. tavola -Table knife - Couteau de table - Tafelmesser - Cuchillo mesa
000C	Colt. tav. m.v. lama forg. -Table knife H.H and forg. blade - Cout. de table à m.c. et lame forg. - Tafelhohelhtm. mit geschm. Klinge - Cuch. mesa con m.h. y hoja forj.
000A	Colt. tav. senza bilancio - Special table knife - Couteau de table spécial - Tafelmesser spezial - Cuchillo mesa
00L3	Colt. tav. stamp. - Stamp. table knife - Cout. de table estampé - Tafelmesser - Gestanzt Cuc. mesa estampado
0067	Cottello bistecca - Steak knife - Couteau à steak - Steakmesser - Cuchillo chuleta
0004	Cucchiaio frutta -Dessert spoon - Cuiller dessert - Dessertlöffel - Cuchara postre
0005	Forchetta frutta - Dessert fork - Fourchette dessert - Dessertgabel - Tenedor postre
0006	Cottello frutta - Dessert knife - Couteau dessert - Dessertmesser - Cuchillo postre
00L6	Colt. frutta stamp. - Stamp. dessert knife - Cout. dess. estampé - Dessertmess. gestanzt - Cuc. postre estamp.
00CD	Colt. frutta m.v. lama forg. - Dess. knife H.H and forg. blade - Cout. diss. à m.c. et lame forg. - Dessertrohheftm. mit geschm. Klinge - Cuch. postre con m.h. y hoja forj.
00CB	Colt. frut. senza bilancio - Special dessert knife - Cout. dessert spécial - Dessertmess. spezial - Cuc. postre
0007	Cucchiaino caffè - Tea-coffee spoon - Cuiller à café - Kaffeelöffel - Cuchara café
0008	Cucchiaino moka - Moka spoon - Cuiller à moka - Mokkalöffel - Cuchara moka
0010	Mestolo - Soup ladle - Louche - Suppenschöpfer - Cazo sopa
0011	Cucchiaione - Serving spoon - Cuiller de service - Gemüselöffel - Cuchara servir
0012	Forchettone - Serving fork - Fourchette de service - Serviergabel - Tenedor servir
0013	Mestolo salsa - Sauce ladle - Louche à sauce - Saucenlöffel - Cacillo salsa
0014	Cucchiaio insalata - Salad spoon - Cuiller à salade - Salatöffel - Cuchara ensalada
0015	Forchetta insalata - Salad fork - Fourchette à salade - Salatgabel - Tenedor ensalada
0016	Forchettina dolce 4 spine - Pastry fork - Fourchette à gateau - Kuchengabel 4 Zinken - Tenedor postre 4 púas
0059	Cucchiaione risotto - Rice spoon - Cuiller à "risotto" - Reislöffel - Cuchara de arroz
00AW	Mestolo Zakouski - Zakouski ladle - Louche Zakouski - Zakouski schöpfer - Cacillo Zakouski
0017	Forchettina dolce 3 spine - Pastry fork - Fourchette à gateau - Kuchengabel 3 Zinken - Tenedor postre 3 púas
0018	Cucchiaino dolce - Tea-cake spoon - Cuiller à gateau - Kuchenlöffel - Cuchara postre
00L9	Cottellino stamp. - Stamp. cake knife - Cout. à gateau estampé - Kuchenmess. gestanzt - Cuch. estampado
0019	Cottellino dolce - Pastry knife - Couteau à gateau - Kuchenmesser - Cachillo postre
0020	Pala torta - Cake server - Pelle à tarte - Tortenheber - Pala pastel
0052	Cucchiaino bebè - Baby spoon - Cuiller à bébé - Babyloeffel - Cucharita bebé
00CR	Cucchiaio crema - Cream spoon - Cuiller à crème - Sahnelöffel - Cuchara crema
0009	Forchetta carne - Meat fork - Fourchette à viande - Vorlegegabel - Tenedor carne
0022	Paletta gelato - Ice cream spoon - Cuiller à glace - Eislöffel - Cuchara para helado
0023	Cucchiaio formaggio - Grated-cheese spoon - Cuiller à parmesan - Käselöffel - Cuchara para queso
0025	Spalma burro - Butter spreader - Couteau à beurre - Buttermesser - Pala mantequilla
00CS	Colt. burro m.v. lama forg. - Butter spr. H.H. & forg blade - Cout. à beurre à m.c. et lame forg. - Hohlheft-Butter messer mit geschm. Klinge - Pala manteq. m.h. y hoja forj.
0026	Forchetta lumache - Snail fork - Fourchette à escargots - Schneck kengabel - Tenedor caracoles
0027	Forchetta ostriche - Oyster fork - Fourchette à huîtres - Austerngabel - Tenedor ostras
00FM	Forchetta molluschi - Shellfish fork - Fourchette à crustacés - Austerngabel - Tenedor marisco
0035	Sessola zucchero - Sugar spoon - Cuiller à sucre - Zuckerlöffel - Cuchara para azucarera
0036	Cucchiaino bibita - Long drink spoon - Cuiller à drink - Limolöffel - Cuchara refresco
0038	Cucchiaio gourmet/salsa - Gourmet spoon - Cuiller gourmet - Gourmetlöffel - Cuchara gourmet/salsa
0039	Cucchiaio brodo - Soup spoon - Cuiller à soupe - Fleischbrühelöffel - Cuchara caldo
00AT	Cucchiaio Zakouski - Zakouski spoon - Cuiller Zakouski - Zakouskilöffel - Cuchara Zakouski
0028	Forchetta pesce - Fish fork - Fourchette à poisson - Fischgabel - Tenedor pescado
0029	Cottello pesce - Fish knife - Couteau à poisson - Fischmesser - Cuchillo pescado
0030	Forc. pesce servire - Fish serving fork - Fourc. à servir poisson - Fischserviergabel - Tenedor servir pescado
0031	Colt. pesce servire - Fish serving knife - Cout. à servir poisson - Fischserviermesser - Cuchillo servir pescado

Cucchiaio tavola - Table spoon - Cuiler de table - Tafelöffel - Cuchara mesa	0001
Forchetta tavola -Table fork - Fourchette de table - Tafelgabel - Tenedor mesa	0002
Colt. tavola -Table knife - Couteau de table - Tafelmesser - Cuchilo mesa	0003
Colt. tav. m.v. lama forg. -Table knife H.H and forg. blade - Cout. de table à m.c. et lame forg. - Tafelhohelhtm. mit geschm. Klinge - Cuch. mesa con m.h. y hoja forj.	000C
Colt. tav. senza bilancio - Special table knife - Couteau de table spécial - Tafelmesser spezial - Cuchillo mesa	000A
Colt. tav. stamp. - Stamp. table knife - Cout. de table estampé - Tafelmesser - Gestanzt Cuc. mesa estampado	00L3
Cottello bistecca - Steak knife - Couteau à steak - Steakmesser - Cuchillo chuleta	0067
Cucchiaio fruta -Dessert spoon - Cuiller dessert - Dessertlöffel - Cuchara postre	0004
Forchetta frutta - Dessert fork - Fourchette dessert - Dessertgabel - Tenedor postre	0005
Cottello frutta - Dessert knife - Couteau dessert - Dessertmesser - Cuchillo postre	0006
Colt. frutta stamp. - Stamp. dessert knife - Cout. dess. estampé - Dessertmess. gestanzt - Cuc. postre estamp	00L6
Colt. frutta m.v. lama forg. - Diss. knife H.H and forg. blade - Cout. diss. à m.c. et lame forg. - Dessertrohheftm. mit geschm. Klinge - Cuch. postre con m.h. y hoja forj.	00CD
Colt. frut. senza bilancio - Special dessert knife - Cout. dessert spécial - Dessertmess. spezial - Cuc. postre	00CB
Cucchiaino caffè - Tea-coffee spoon - Cuiller à café - Kaffeelöffel - Cuchara café	0007
Cucchiaino moka - Moka spoon - Cuiller à moka - Mokkalöffel - Cuchara moka	0008
Mestolo - Soup ladle - Louche - Suppenschöpfer - Cazo sopa	0010
Cucchiaione - Serving spoon - Cuiller de service - Gemüselöffel - Cuchara servir	0011
Forchettone - Serving fork - Fourchette de service - Serviergabel - Tenedor servir	0012
Mestolo salsa - Sauce ladle - Louche à sauce - Saucenlöffel - Cacillo salsa	0013
Cucchiaio insalata - Salad spoon - Cuiller à salade - Salatöffel - Cuchara ensalada	0014
Forchetta insalata - Salad fork - Fourchette à salade - Salatgabel - Tenedor ensalada	0015
Forchettina dolce 4 spine - Pastry fork - Fourchette à gateau - Kuchengabel 4 Zinken - Tenedor postre 4 púas	0016
Cucchiaione risotto - Rice spoon - Cuiller à "risotto" - Reislöffel - Cuchara de arroz	0059
Mestolo Zakouski - Zakouski ladle - Louche Zakouski - Zakouski schöpfer - Cacillo Zakouski	00AW
Forchettina dolce 3 spine - Pastry fork - Fourchette à gateau - Kuchengabel 3 Zinken - Tenedor postre 3 púas	0017
Cucchiaino dolce - Tea-cake spoon - Cuiller à gateau - Kuchenlöffel - Cuchara postre	0018
Cottellino stamp. - Stamp. cake knife - Cout. à gateau estampé - Kuchenmess. gestanzt - Cuch. estampado	00L9
Cottellino dolce - Pastry knife - Couteau à gateau - Kuchenmesser - Cachillo postre	0019
Pala torta - Cake server - Pelle à tarte - Tortenheber - Pala pastel	0020
Cucchiaino bebè - Baby spoon - Cuiler à bébé - Babyloeffel - Cucharita bebé	0052
Cucchiaio crema - Cream spoon - Cuiller à crème - Sahnelöffel - Cuchara crema	00CR
Forchetta carne - Meat fork - Fourchette à viande - Vorlegegabel - Tenedor carne	0009
Paletta gelato - Ice cream spoon - Cuiller à glace - Eislöffel - Cuchara para helado	0022
Cucchiaio formaggio - Grated-cheese spoon - Cuiller à parmesan - Käselöffel - Cuchara para queso	0023
Spalma burro - Butter spreader - Couteau à beurre - Buttermesser - Pala mantequilla	0025
Colt. burro m.v. lama forg. - Butter spr. H.H. & forg blade - Cout. à beurre à m.c. et lame forg. - Hohlheft-Butter messer mit geschm. Klinge - Pala manteq. m.h. y hoja forj.	00CS
Forchetta lumache - Snail fork - Fourchette à escargots - Schneck kengabel - Tenedor caracoles	0026
Forchetta ostriche - Oyster fork - Fourchette à huîtres - Austerngabel - Tenedor ostras	0027
Forchetta molluschi - Shellfish fork - Fourchette à crustacés - Austerngabel - Tenedor marisco	00FM
Sessola zucchero - Sugar spoon - Cuiller à sucre - Zuckerlöffel - Cuchara para azucarera	0035
Cucchiaino bibita - Long drink spoon - Cuiller à drink - Limolöffel - Cuchara refresco	0036
Cucchiaio gourmet/salsa - Gourmet spoon - Cuiller gourmet - Gourmetlöffel - Cuchara gourmet/salsa	0038
Cucchiaio brodo - Soup spoon - Cuiller à soupe - Fleischbrühelöffel - Cuchara caldo	0039
Cucchiaio Zakouski - Zakouski spoon - Cuiller Zakouski - Zakouskilöffel - Cuchara Zakouski	00AT
Forchetta pesce - Fish fork - Fourchette à poisson - Fischgabel - Tenedor pescado	0028
Cottello pesce - Fish knife - Couteau à poisson - Fischmesser - Cuchillo pescado	0029
Forc. pesce servire - Fish serving fork - Fourc. à servir poisson - Fischserviergabel - Tenedor servir pescado	0030
Colt. pesce servire - Fish serving knife - Cout. à servir poisson - Fischserviermesser - Cuchillo servir pescado	0031

Cod. 98900463

Graphic Design **Elena Maccabiani**
Ph **Claudio Sambinelli**

HORECA 2018

PINTINOX

MADE IN ITALY

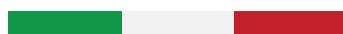

HORECA
2018



HOtellerie REstaurant CAtering

Il catalogo HO.RE.CA. è la raccolta più esauriente di prodotti in acciaio inossidabile destinati alla moderna ristorazione. Il capitolo posate offre l'immagine in scala 1/1 dei pezzi per un'immediata visualizzazione. Lo sviluppo in cucina segue rigorosamente il percorso del cibo dalla preparazione al trasporto sino alla presentazione.

The HO.RE.CA. catalogue is the most exhaustive collection of stainless steel products for today's catering. The catalogue dedicated to cutlery shows a 1/1 scale reproduction of the pieces for quick view. The kitchen development follows the food journey from preparation to transport and packaging.

Le catalogue HO.RE.CA. est la collection la plus complète de produits en acier inox destinés à la restauration moderne. Le chapitre "Couverts" présente l'image des pièces à l'échelle 1/1 pour une visualisation immédiate. Le développement à la cuisine suit rigoureusement le parcours des aliments, de la préparation à la présentation en passant par le transport.

Der HO.RE.CA.-Katalog ist die ausführlichste Sammlung an Produkten aus nichtrostendem Stahl, bestimmt für das moderne Gaststättengewerbe. Das Kapitel Besteck zeigt die massstabgetreue Abbildung der Teile für eine sofortige Darstellung. Die Entwicklung in der Küche verfolgt rigoros den Weg der Speisen von der Vorbereitung über den Transport bis zum Servieren.

El catálogo HO.RE.CA. es la recopilación más completa de los productos de acero inoxidable dirigidos a la restauración moderna. El capítulo "Cubiertos" presenta la imagen de las piezas a escala 1/1 para una visualización inmediata. El desarrollo en la cocina sigue rigurosamente el recorrido de los alimentos, de la preparación a la presentación pasando por el transporte.



INDICE

Index

POSATE	23
<i>Cutlery</i> - <i>Couverts</i> - <i>Bestecke</i> - <i>Cubiertos</i>	
COTTURA	169
<i>Cooking</i> - <i>Cuisson</i> - <i>Küchen</i> - <i>Cocción</i>	
GASTRONORM	229
<i>Gastronorm</i> - <i>Gastronorm</i> - <i>Gastronorm</i> - <i>Gastronorm</i>	
PREPARAZIONE	261
<i>Preparation</i> - <i>La préparation</i> - <i>Vorbereitung</i> - <i>Preparaciòn</i>	
PRESENTAZIONE	271
<i>Presentation</i> - <i>Présentation</i> - <i>Präsentation</i> - <i>Presentaciòn</i>	
UTENSILI	285
<i>Tools</i> - <i>Utensiles</i> - <i>Zubehör</i> - <i>Uensilos</i>	
BAR/GELATERIA	321
<i>Bar/Icecream</i> - <i>Bar/Crème glacée</i> - <i>Bar/Eis</i> - <i>Bar/Helado</i>	
BUFFET	349
<i>Buffet</i> - <i>Buffet</i> - <i>Buffet</i> - <i>Buffet</i>	
RICAMBI	367
<i>Spare parts</i> - <i>Pièces de rechanges</i> - <i>Ersatzteile</i> - <i>Piezas de repuesto</i>	
ESPOSITORI	378
<i>Display</i> - <i>Présentoir</i> - <i>Wandaussteller</i> - <i>Expositor</i>	
SEZIONE ESPLICATIVA	389
<i>Technical Information</i> - <i>Information Technique</i> - <i>Technische Informationen</i> - <i>Información Técnica</i>	
FINITURE SPECIALI	400
<i>Technical Information</i> - <i>Finitions Spéciales</i> - <i>Sonderausführungen</i> - <i>Acabados Especiales</i>	
INDICE GENERALE	415
<i>Index</i> - <i>Index</i> - <i>Inhaltsverzeichnis</i> - <i>Índice</i>	

LA STORIA

History

L'azienda **Pinti Inox S.p.A.** è localizzata in un'area "la Valtrompia" che da sempre è stata dedicata alla lavorazione dei metalli. Dai tempi degli antichi Romani, le miniere di ferro, i monti boscosi per la produzione di carbone di legna, e la forza motrice dell'acqua dei torrenti hanno favorito l'industria metallurgica. Già dal Medio Evo la zona era conosciuta come centro di produzione di armi e lame. Nel 1929, dopo la grande crisi, Giacomo Pinti decide di mettersi in proprio e costruire la sua prima officina in Lumezzane per la lavorazione di posate in ottone cromato e coltelleria. Successivamente l'azienda è cresciuta fino a diventare un'importante entità industriale. In questi anni di storia l'azienda si è evoluta ed è diventata leader nel settore della posateria. Oggi siamo alla terza generazione, con ogni membro della famiglia a presiedere un ruolo chiave nell'azienda. Lo sforzo di modernizzazione ha portato la società a dotarsi di automatismi industriali ed al rinnovamento delle gamme di prodotti. È dal 1929 che la nostra azienda è leader nella posateria ed offre numerose linee complete (classiche, moderne, di tendenza). Le gamme si abbinano perfettamente a tutti gli stili delle porcellane esistenti per creare un insieme armonioso sulle tavole eleganti. Le linee sono sempre complete di tutte le pezzature necessarie ed alcune versioni hanno anche il coltello manico cavo, lama forgiata.

***Pinti Inox S.p.A.** is situated in an area known as "Valtrompia" which has always been linked strongly with the metal-working sector. Since the days of the Ancient Romans, the iron mines and tree-covered mountains for the production of coal, joined by the driving force of the water flowing along the rivers, have favoured the metallurgy industry. The area was well known for the production of weapons and blades as early as the Middle Ages. In 1929, after the great recession, Giacomo Pinti decided to set up his own business, opening his first workshop in Lumezzane, where he produced chrome-plated brass cutlery and knives. The company subsequently grew and developed into an important industrial concern. Nowadays the third generation of the family runs the company. Each member oversees a key role in the company. Considerable modernisation has led the company to acquire industrial automated systems and fully renew the product ranges. Our company has been a leader in the cutlery market since 1929. We offer a variety of complete ranges in classic, modern and fashionable styles that make a perfect match with all styles of tableware and go together to create a harmonious ensemble for elegant tabletop. Our lines offer all the accessories you may require to beautifully set your table and some of them have hollow handle knives with forged blades.*



L'AZIENDA

The company

Oggi l'azienda vanta un'entità produttive e due unità distributive:

- 1.SAREZZO (ITALY): Pintinox S.p.A. con lo stabilimento di Sarezzo che occupa 15.000 m² coperti, in cui vi sono le produzioni di: tutti gli stampi ed attrezzature del gruppo, posateria con cicli completi, posateria forgiata, coltelleria, vasellame e accessori, pentolame professionale, linee buffet ed articoli professionali.
- 2.GERMANY: In Germania la società Pinti inox GmbH si occupa della distribuzione sul territorio tedesco.

Today the company has two production units and three distribution units:

- 1.SAREZZO (ITALY): *Pintinox S.p.A. with the Sarezzo plant, occupying an indoor area of 15,000 m², housing production of: all the group's moulds and equipment, complete cycle cutlery, forged cutlery, knives, tableware and accessories, professional pans, buffet line and professional articles.*
- 2.GERMANY: *In Germany, Pinti inox GmbH handles distribution throughout German territory.*



DNV

Quality Certificate

MANAGEMENT SYSTEM CERTIFICATE

Certificato no./Certificate No.:
CERT-07553-2000-AQ-MIL-SINCERT

Data prima emissione/Initial date:
14 dicembre 2000

Validità:/Valid:
04 marzo 2018 - 04 marzo 2021

Si certifica che il sistema di gestione di/This is to certify that the management system of

PINTI INOX S.p.A. Sede Legale ed Operativa

Via Antonini, 87 - 25068 Sarezzo (BS) - Italy

È conforme ai requisiti della norma per il Sistema di Gestione Qualità/
has been found to conform to the Quality Management System standard:
ISO 9001:2015

Questa certificazione è valida
per il seguente campo applicativo:

**Progettazione e produzione di: posateria,
pentolame per uso domestico, alberghiero e
catering ed oggetti in acciaio inox per la
tavola e la cucina (EA 17)**

This certificate is valid
for the following scope:

**Design and manufacture of: cutlery, cookware
for domestic, hotels and catering uses,
stainless steel tableware and kitchen
accessories (EA 17)**

Luogo e Data/Place and date:
Vimercate (MB), 01 marzo 2018



SGQ N° 003 A
SGA N° 003 D
SSE N° 007 F
SCL N° 004 F

ENAS N° 009 P
IRG N° 003 B
PRG N° 004 C
SRI N° 002 G

Membro di MSA EA per gli schemi di accreditamento
SGQ, SGA, PRO, PRL, SRF, GHG, LAB e LAT di MSA IAF
per gli schemi di accreditamento SGQ, SGA, SRS, PSM
e PRO e di MSA UK per gli schemi di accreditamento
LAB, MRO, LAT e TSP

Per l'Organismo di Certificazione/
For the Certification Body
DNV GL - Business Assurance
Via Energy Park, 14 - 20871 Vimercate
(MB) - Italy

Zeno Beltrami
Management Representative

La validità del presente Certificato è subordinata al rispetto delle condizioni contenute nel Contratto di Certificazione/
Lack of fulfilment of conditions as set out in the Certification Agreement may render this Certificate invalid.
DNV GL Business Assurance Italia S.r.l., Via Energy Park, 14 - 20871 Vimercate (MB) - Italy. TEL: 039 68 99 905. www.dnvgl.it

PINTI1929

MADE IN ITALY

E' la linea più prestigiosa che racchiude quasi 90 anni di storia. Identifica la gamma più importante della ns. produzione. In cui qualità, ricerca e innovazione si fondono in prodotti unici ed esemplari.

It is the most prestigious line that includes nearly 90 years of history. *This brand identifies the most important range of our production: quality, design, research and innovation come together in unique products.*



PINTINOX

MADE IN ITALY

E' il nostro Marchio, la nostra identità.

I prodotti raggruppati sotto questo marchio sono tutti i prodotti di uso quotidiano, strumenti e accessori che caratterizzano maggiormente la nostra azienda che ottimizzano il rapporto qualità prezzo nella vita di tutti i giorni.

This is our brand , our identity.

The products grouped under this brand are for a daily use. Tools and accessories that most characterize our company willing to produce value for money products for everyday life.





Marchio storico del mercato spagnolo identificato con prodotti di ottima qualità e finiture superiori. Prodotti ispirati da un design raffinato e ricercato, dedicati ad un mercato esigente.

Historical brand of the Spanish market known for high quality products and superior finishes. Products inspired by a refined and sophisticated design , dedicated to a demanding market.



Marchio storico Spagnolo, ma ormai riconosciuto a livello europeo, che definisce prodotti dedicati ad un mercato di largo consumo che si prefissa l'obiettivo di fornire ai propri clienti, prodotti con fasce prezzo estremamente accessibili, ma senza mai rinunciare alla qualità che contraddistingue e che ha sempre contraddistinto l'intero ventaglio di proposte del Gruppo Pinti.

Historical Spanish brand, it is nowadays widely recognized in Europe. The brand Monix defines products dedicated to a large consumer market. In recognition of the continued need for value options this collection offers items at affordable price whilst ensuring good quality, meeting the consumer market requirements.



EFFICIENT pag.218



MINERAL





FINITURE SPECIALI

Special finished

ON
DEMAND

TREASURE - GOLD, BRONZE, TITANIUM, TOTAL BLACK

Titanio, bronzo e oro: le nostre posate diventano dei pezzi unici, inimitabili e indimenticabili. Grazie a sofisticate tecnologie all'avanguardia, trasformiamo le nostre più belle posate classiche e di design in veri e propri tesori per la tavola. Le posate Treasure sono rivestite in PVD (acronimo di Physical Vapour Deposition), depositi metallici superficiali, sotto forma di film molto sottili, ottenuti con tecnologie altamente innovative che permettono di ottenere durezza superficiali molto elevate. A ciò si aggiunge la possibilità di ottenere diversi tipi di colorazioni senza alterare la lucentezza tipica dell'acciaio né l'atocissità del prodotto, che può quindi entrare in contatto con gli alimenti. Ordine minimo 240 pz assortiti per colore. In ogni caso non si accettano ordini inferiori ai 36 pz per pezzatura e a 6 pz per i servire.

Titanium, bronze, gold: our cutlery comes alive and becomes unique and unforgettable. Thanks to our sophisticated and avant-garde technologies, our most beautiful and classic cutlery becomes design cutlery and a real treasure for the table. The Treasure cutlery describes a variety of vacuum deposition methods used to deposit this films by the condensation of vaporized form of the desired film material onto various workpiece surfaces. The result is a higher hardness surface and the possibility to obtain different colors without altering the polished steel. Minimum order quantity 240 pcs mixed per colour. In any case orders under 36 pcs assorted and 6 pcs serving cutlery will be not accepted.

STONE WASHED

La Collezione Stone Washed nasce dal desiderio di esaltare la propria tavola in perfetto stile retrò con articoli ricercati e di ottima fattura. I prodotti, attentamente selezionati nelle gamme Pintinox e Pinti 1929, sono antichizzati con uno speciale processo detto Stone Wash: il risultato è un prodotto unico nell'aspetto e qualitativamente perfetto. Per garantire un elevato standard di qualità, tutti i coltelli sono stati riaffilati dopo avere subito il trattamento Stone Wash. Tutte le serie proposte sono complete di tutte le pezzature e già disponibili per la vendita. Ordine minimo 120 pz per pezzatura.

The Stone Washed Collection is a selection from Pintinox cutlery assortment. The aim is to offer quality cutlery to the customers willing to create a retro atmosphere when laying their tables. This cutlery has been stone washed to create a vintage effect on the stainless steel, intentionally creating a finish with a non-uniform appearance; each piece is therefore unique. All our knives have been resharpened after the Stone Wash process to ensure the usual high quality standard. Minimum order quantity 120 pcs per item.

ALCHIMIQUE - GOLD, BRONZE, TITANIUM

Alchimique una preziosa finitura PVD che conferisce tre tonalità esclusive e pregiate alle posate della Collezione Stone Washed: Gold, gioielli sulla tavola; Bronze, metallo naturale; Titanium, la forza unita allo stile. Ordine minimo 240 pz assortiti per colore. In ogni caso non si accettano ordini inferiori ai 36 pz per pezzatura e a 6 pz per i servire.

Alchimique is a precious PVD coating made in 3 different special colors for an astonish Stone Washed Cutlery Collection. Gold, jewellery on the table. Bronze, pure metal. Titanium, power and style. Minimum order quantity 240 pcs mixed per colour. In any case orders under 36 pcs assorted and 6 pcs serving cutlery will be not accepted.

MYSTIQUE

Finitura raffinata ed elegante, delicatamente ruvida al tatto. Grazie a un processo di sabbiatura profonda ogni articolo è resistente ad urti e abrasioni ed è adatto all'utilizzo anche nella ristorazione professionale. Ordine minimo 60 pz per pezzatura.

Sandblasted stainless steel for an elegant mat finishing. Thanks to a deep sandblasting process, every item is strike and abrasion resistant and suitable for using in Horeca. Minimum order quantity 60 pcs per item.

ARGENTATURA - SILVER PLATED EN1=10 MIC.

L'argentatura della nostra posateria si basa su 50 anni di esperienza e su una tecnologia avanzata. Il materiale base è l'acciaio al 18/10, sul quale viene applicato uno strato di argento spesso 10 micron tramite processo galvanico. Sulle parti esposte ad un'usura maggiore, come le punte della forchetta ed i punti di appoggio, viene apportato un doppio strato al fine di garantire all'argentatura una durata omogenea nel tempo. Sebbene possibile si sconsiglia il lavaggio in lavastoviglie. Ordine minimo 240 pz assortiti per pezzatura. In ogni caso non si accettano ordini inferiori ai 36 pz per pezzatura e a 6 pz per i servire.

Our silver plating process for cutlery is based on 50 years of experience and state-of-art technology. The basic material is stainless steel 18/10 to which a 10-micron layer of silver is applied by galvanisation. The parts most exposed to wear, such as the tips and resting points are given a double layer to guarantee long-lasting plating. Thick plate silverware can't be washed in the dishwasher. Minimum order quantity 240 pcs per item. In any case orders under 36 pcs assorted and 6 pcs serving cutlery will be not accepted.

ARGENTATURA 30 MICRON SU RICHIESTA - SILVER PLATING 30 MICRON ON REQUEST

Ordine minimo 240 pz assortiti per colore. In ogni caso non si accettano ordini inferiori ai 36 pz per pezzatura e a 6 pz per i servire. - *Minimum order quantity 240 pcs per item. In any case orders under 36 pcs assorted and 6 pcs serving cutlery will be not accepted.*

Aggiungere al prezzo dello sfuso - Add to the price of the unpacked item - Ajouter au prix des pièces en vrac - Dem Preis des nicht verpackten Artikels - Adicionar al precio del artículo no acondicionado

Per griglie Finiture Speciali vedi pag 400 / For Special Finished tables see page 400

LISTINO FINITURE SPECIALI PER VARIANTI ON DEMAND

Special Finished on demand price list

Cod.	Descrizione - Description	Treasure Gold Euro	Treasure Bronze Titanium Euro	Treasure Total Black Euro	Stone Washed Euro	Alchimique Gold Euro	Alchimique Bronze Titanium Euro	Mystique Euro	Argentatura Silver Plated (10 µ) Euro
01	Cucch. tavola - Table spoon - Cuiller de table - Tafelöffel - Cuchara mesa	5,20	8,30	4,90	0,64	5,84	8,94	1,10	7,00
02	Forch. tavola - Table fork - Fourchette de table - Tafelgabel - Tenedor mesa	5,20	8,30	4,90	0,64	5,84	8,94	1,10	5,90
03	Colt. tavola - Table knife - Couteau de table - Tafelmesser - Cuchillo mesa	5,20	8,30	4,90	0,74	5,94	9,04	1,10	7,00
CC	Colt. tavola m.v. lama forg. - Table knife H.H and forged blade - Couteau de table à m.c. et lame forgée - Tafelhohlheftmesser mit geschmiedeter Klinge - Cuchillo mesa con m.h. y hoja forjada	-	-	-	0,74	-	-	1,10	7,80
04	Cucch. frutta - Dessert spoon - Cuiller dessert - Dessertlöffel - Cuchara postre	5,20	8,30	4,20	0,64	5,84	8,94	1,00	6,20
05	Forch. frutta - Dessert fork - Fourchette dessert - Dessertgabel - Tenedor postre	5,20	8,30	4,20	0,64	5,84	8,94	1,00	5,30
06	Colt. frutta - Dessert knife - Couteau dessert - Dessertmesser - Cuchillo postre	5,20	8,30	4,20	0,74	5,94	9,04	1,00	7,20
CD	Colt. frutta m.v. lama forg. - Dessert knife H.H and forged blade - Couteau dessert à m.c. et lame forgée - Dessert-hohlheftmesser mit geschmiedeter Klinge - Cuchillo postre con m.h. y hoja forjada	-	-	-	0,74	-	-	1,00	7,20
07	Cucch. caffè - Tea-coffee spoon - Cuiller à café - Kaffeelöffel - Cuchara café	4,30	5,70	3,30	0,54	4,84	6,24	0,92	4,00
08	Cucch. moka - Moka spoon - Cuiller à moka - Mokkalöffel - Cuchara moka	3,80	5,70	3,10	0,54	4,34	6,24	0,92	3,00
10	Mestolo - Soup ladle - Louche - Suppenschöpfer - Cazo sopa	20,90	24,90	16,60	1,70	22,60	26,60	1,40	28,90
11	Cucchiavone - Serving spoon - Cuiller de service - Gemüselöffel - Cuchara servir	8,80	11,30	8,40	0,96	9,76	12,26	1,30	8,40
12	Forchettone - Serving fork - Fourchette de service - Serviergabel - Tenedor servir	8,80	11,30	8,40	0,96	9,76	12,26	1,30	8,40
13	Mestolo salsa - Sauce ladle - Louche à sauce - Saucenlöffel - Cacillo salsa	20,90	24,90	16,60	1,70	22,60	26,60	1,40	12,00
15	Forch. insalata - Salad fork - Fourchette à salade - Salatgabel - Tenedor ensalada	8,80	11,30	8,40	0,96	9,76	12,26	1,30	8,40
16	Forch. dolce 4 spine - Pastry fork - Fourchette gateau - Kuchengabel 4 Zinken - Tenedor postre 4 p as	5,20	8,30	4,20	0,64	5,84	8,94	1,00	5,30
17	Forch. 3 spine - Pastry fork - Fourchette à gateau - Kuchengabel 3 Zinken - Tenedor postre 3 púas	5,20	8,30	3,30	0,64	5,84	8,94	0,92	3,60
18	Cucch. dolce - Tea-cake spoon - Cuiller à gateau - Kuchenlöffel - Cuchara postre	5,20	8,30	4,20	0,64	5,84	8,94	1,00	4,40
19	Colt. dolce - Pastry knife - Couteau à gateau - Kuchenmesser - Cuchillo postre	5,20	8,30	4,20	0,74	5,94	9,04	1,00	6,60
20	Pala torta - Cake server - Pelle à tarte - Tortenheber - Pala pastel	17,50	22,80	15,70	0,96	18,46	23,76	1,30	12,00
CR	Cucch. crema - Cream spoon - Cuiller à crème - Sahnelöffel - Cuchara crema	5,20	8,30	4,20	0,64	5,84	8,94	1,00	4,40
39	Cucch. brodo - Soup spoon - Cuiller à soupe - Fleischbrühelöffel - Cuchara caldo	5,20	8,30	4,20	0,64	5,84	8,94	1,10	6,30
22	Paletta gelato - Ice cream spoon - Cuiller à glace - Eislöffel - Cuchara para helado	5,20	8,30	4,20	0,64	5,84	8,94	1,10	3,70
36	Cucch. bibita - Long drink spoon - Cuiller à drink - Limolöffel - Cuchara refresco	8,80	11,30	8,40	0,96	9,76	12,26	1,10	4,70
28	Forch. pesce - Fish fork - Fourchette à poisson - Fischgabel - Tenedor pescado	5,20	8,30	4,90	0,64	5,84	8,94	1,10	5,30
29	Colt. pesce - Fish knife - Couteau à poisson - Fischmesser - Cuchillo pescado	5,20	8,30	4,90	0,64	5,84	8,94	1,10	5,30
30	Forch. pesce servire - Fish serving fork - Fourchette à servir poisson - Fischserviergabel - Tenedor servir pescado	8,80	11,30	8,40	0,96	9,76	12,26	1,30	9,00
31	Colt. pesce servire - Fish serving knife - Couteau à servir poisson - Fischserviermesser - Cuchillo servir pescado	8,80	11,30	8,40	0,96	9,76	12,26	1,30	9,00

PUNZONATURA

Marking

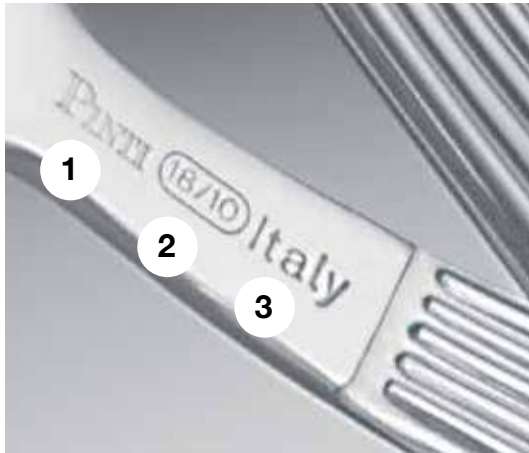

La punzonatura consiste nel simbolo di identificazione delle parti ed ha il seguente significato:

- 1.Nome del costruttore
- 2.Materiale utilizzato
- 3.Paese d'origine del costruttore

Marking is the identification mark of pieces and means:

- 1.Name of manufacturer
- 2.Material
- 3.Manufacturer's place of origin



Punzonatura Meccanica:

Cod. S0001000 - Si ottiene quando il logo viene stampato durante la produzione dell'articolo. Non vengono accettati ordini inferiori ai 1200 pz x pezzatura. Il costo per l'attrezzatura macchina e per la realizzazione dei punzoni personalizzati è di 500,00 Euro netti per pezzatura che verranno aggiunti a fondo fattura.

Mechanical Stamped:

Cod. S0001000 - This process is reached when a logo is stamped during the production of the article. The minimum order accepted is 1200 pieces for item. The net cost to equip the machine and to realize personalized punches is 500,00 Euros each item and it will be added at the end of the invoice.



Punzonatura Laser:

quando il logo viene applicato con questa tecnica non vengono accettati ordini per quantitativi inferiori ai 240 pz. per pezzatura.

Da 240 a 600 pz. Euro 0,20 netti al pezzo

Da 601 a 1.200 pz. Euro 0,15 netti al pezzo -
oltre i 1.200 pz. Euro 0,10 netti al pezzo (Spese a punzone Euro 60,00 netti).

Laser Stamping:

when laser stamping is used, we only accept orders for more than 240 pcs for each item.

From 240 to 600 pcs Euro 0,20 net per pce

From 601 to 1.200 pcs Euro 0,15 net per pce -

More than 1.200 pcs Euro 0,10 net per pce (Net tooling costs Euro 60,00).





P O S A T E

C u t l e r y

C o u v e r t s

B e s t e c k e

C u b i e r t o s

PINTI1929
MADE IN ITALY

Relais
Chateaux

PINTINOX
MADE IN ITALY

Hotel
Division



Per alimenti
Suitable for foodstuffs
Apte au contact avec les aliments
Für Lebensmittel
Apto para alimentos



Garantito per lavastoviglie
Dishwasher safe
Inalterable dans lave-vaisselle
Spelmaschinenfest
Apto para lavavajillas



POSATE 1:1

Size cutlery 1:1

Come scegliere una posata.

È la cosa più facile del mondo!

Basta definire il piatto e facilmente si trova l'abbinamento più efficace, sfogliando il catalogo. Le foto delle posate sono in scala 1/1: accostando il piatto alla fotografia della posata si può verificare immediatamente l'aspetto scenico e definire la scelta.

How to choose cutlery.

Nothing could be easier!

All you have to do is select a plate and you can then find the best match by simply flicking through our catalogue. The photos of our cutlery are on a 1/1 scale which means that by placing your plate next to the photo of the cutlery you can immediately see how well they go together and make your choice.

Comment choisir un couvert.

C'est la chose la plus simple du monde!

Il suffit de définir l'assiette et de feuilleter le catalogue pour trouver aisément l'association la plus efficace. Les photos des couverts sont à l'échelle 1/1: en associant la vaisselle à la photographie du couvert, vous pouvez vérifier immédiatement l'effet et définir votre choix.

Und so wählen Sie ein Besteck aus.

Es ist kinderleicht!

Sie brauchen nur einen Teller festzulegen und schon erscheint beim Blättern im Katalog die wirksamste Zusammenstellung. Das Besteck ist 1:1 abgebildet: Wenn Sie einen Teller neben das Bild stellen, können Sie sofort feststellen, ob dieses passt, und Ihre Wahl treffen.

Cómo elegir un cubierto.

¡Es la cosa más fácil del mundo!

Basta describir el plato y se encuentra siempre la combinación más eficaz, hojeando el catálogo. Las fotos de los cubiertos son en escala 1/1: acercando el plato a la fotografía del cubierto se puede comprobar inmediatamente el efecto y definir la elección.

Cod.	cm	Euro
0001	20,8	10,72
0002	21,1	10,72
0003	23,5	10,72
00CC	-	-
00CA	-	-
00L3	-	-
0067	-	-
0004	18,4	9,86
0005	18,4	9,86
0006	21,3	10,04
00L6	-	-
00CD	-	-
00CB	-	-
0007	15,5	8,80
0008	12,4	8,60
0010	27,2	25,24
0011	23,8	15,80
0012	24,0	15,80
0013	17,5	13,26
0014	-	-
0015	-	-
0016	-	-
0059	-	-
00AW	-	-
0017	16,4	9,72
0018	-	-
00L9	-	-
0019	-	-
0020	25,2	21,20
0052	-	-
00CR	-	-
0009	-	-
0022	-	-
0023	-	-
0025	-	-
00CS	-	-
0026	-	-
0027	-	-
00FM	-	-
0035	-	-
0036	-	-
0038	-	-
0039	18,2	10,08
00AT	-	-
0028	18,6	10,60
0029	20,6	10,60
0030	-	-
0031	-	-

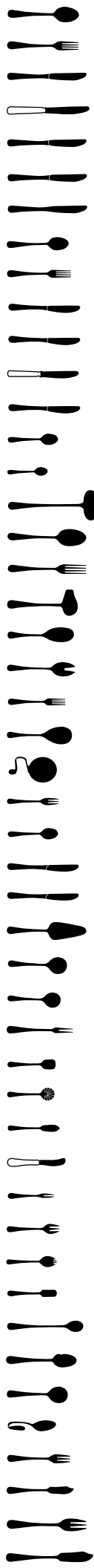

BRAMANTE 0780

PINTI1929

inox 18/10
forgiato - forged



ELLADE

0790

PINTI1929

inox 18/10

forgiato - forged



Cod.	cm	Euro
0001	21,2	10,50
0002	21,1	10,50
0003	24,0	10,92
00CC	-	-
00CA	-	-
00L3	-	-
0067	-	-
0004	18,7	9,68
0005	18,4	9,68
0006	21,7	10,04
00L6	-	-
00CD	-	-
00CB	-	-
0007	15,5	8,64
0008	12,5	8,42
0010	27,2	24,76
0011	24,4	15,50
0012	24,5	15,50
0013	18,9	13,00
0014	-	-
0015	-	-
0016	-	-
0059	-	-
00AW	-	-
0017	16,4	9,36
0018	-	-
00L9	-	-
0019	-	-
0020	24,6	20,80
0052	-	-
00CR	-	-
0009	-	-
0022	-	-
0023	-	-
0025	-	-
00CS	-	-
0026	-	-
0027	-	-
00FM	-	-
0035	-	-
0036	-	-
0038	-	-
0039	17,9	9,98
00AT	-	-
0028	18,6	10,40
0029	20,6	10,40
0030	-	-
0031	-	-

Cod.	cm	Euro
0001	20,4	8,20
0002	20,3	8,20
0003	23,5	6,38
00CC	-	-
00CA	-	-
00L3	-	-
0067	-	-
0004	-	-
0005	18,3	7,26
0006	21,2	5,52
00L6	-	-
00CD	-	-
00CB	-	-
0007	14,3	5,16
0008	11,4	5,04
0010	27,7	17,96
0011	23,1	10,82
0012	24,1	10,82
0013	17,2	12,50
0014	-	-
0015	-	-
0016	-	-
0059	-	-
00AW	-	-
0017	15,3	5,46
0018	-	-
00L9	-	-
0019	-	-
0020	24,1	11,34
0052	-	-
00CR	-	-
0009	-	-
0022	-	-
0023	-	-
0025	-	-
00CS	-	-
0026	-	-
0027	-	-
00FM	-	-
0035	-	-
0036	-	-
0038	-	-
0039	18,4	7,26
00AT	-	-
0028	18,4	7,68
0029	20,1	7,88
0030	-	-
0031	-	-

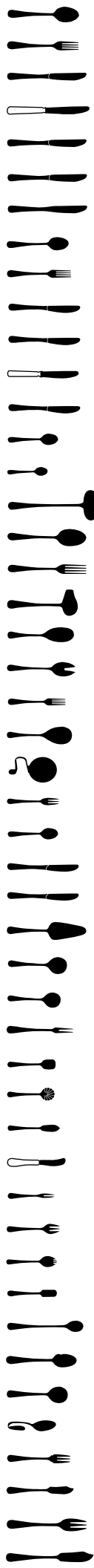

HERMITAGE

0870

PINTI1929

inox 18/10
forgiato - *forged*



PRIVILEGE

0510

PINTI1929

inox 18/10

mm 4,0



Cod.	cm	Euro
0001	21,0	6,14
0002	21,4	6,14
0003	23,0	7,14
00CC	-	-
00CA	-	-
00L3	-	-
0067	-	-
0004	18,5	6,04
0005	18,7	6,04
0006	21,0	6,80
00L6	-	-
00CD	-	-
00CB	-	-
0007	14,5	4,26
0008	12,5	4,16
0010	27,8	16,74
0011	23,6	9,36
0012	24,0	9,36
0013	18,5	10,50
0014	-	-
0015	-	-
0016	-	-
0059	-	-
00AW	-	-
0017	16,6	4,68
0018	-	-
00L9	-	-
0019	-	-
0020	26,0	12,06
0052	-	-
00CR	-	-
0009	-	-
0022	-	-
0023	-	-
0025	-	-
00CS	-	-
0026	-	-
0027	-	-
00FM	-	-
0035	-	-
0036	-	-
0038	-	-
0039	18,2	5,94
00AT	-	-
0028	18,9	6,34
0029	21,2	6,34
0030	-	-
0031	-	-

Cod.	cm	Euro
0001	20,5	5,88
0002	20,7	5,88
0003	23,5	6,06
00CC	-	-
00CA	-	-
00L3	-	-
0067	-	-
0004	18,1	5,46
0005	18,3	5,46
0006	20,5	5,62
00L6	-	-
00CD	-	-
00CB	-	-
0007	13,9	2,74
0008	12,0	2,52
0010	29,5	18,90
0011	24,0	9,36
0012	24,0	9,36
0013	17,3	11,04
0014	-	-
0015	-	-
0016	-	-
0059	-	-
00AW	-	-
0017	15,5	3,06
0018	-	-
00L9	-	-
0019	-	-
0020	24,3	10,50
0052	-	-
00CR	-	-
0009	-	-
0022	-	-
0023	-	-
0025	-	-
00CS	-	-
0026	-	-
0027	-	-
00FM	-	-
0035	-	-
0036	-	-
0038	-	-
0039	-	-
00AT	-	-
0028	18,2	5,46
0029	20,7	5,62
0030	-	-
0031	-	-

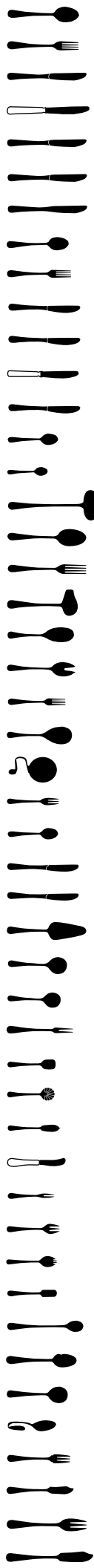

OCTAVIA 0860

PINTI1929

inox 18/10
mm 4,0





Cod.	cm	Euro
0001	20,9	4,38
0002	20,9	4,38
0003	24,0	6,80
00CC	24,5	11,02
00CA	-	-
00L3	-	-
0067	-	-
0004	18,8	4,26
0005	18,6	4,26
0006	21,5	6,70
00L6	-	-
00CD	21,5	10,92
00CB	-	-
0007	14,5	2,18
0008	12,0	2,18
0010	28,2	15,40
0011	24,2	7,60
0012	24,0	7,60
0013	17,8	8,84
0014	-	-
0015	-	-
0016	-	-
0059	-	-
00AW	-	-
0017	15,9	2,82
0018	-	-
00L9	-	-
0019	-	-
0020	24,8	10,62
0052	-	-
00CR	-	-
0009	-	-
0022	-	-
0023	-	-
0025	-	-
00CS	-	-
0026	-	-
0027	-	-
00FM	-	-
0035	-	-
0036	-	-
0038	-	-
0039	17,7	4,26
00AT	-	-
0028	18,7	4,58
0029	21,0	4,58
0030	-	-
0031	-	-

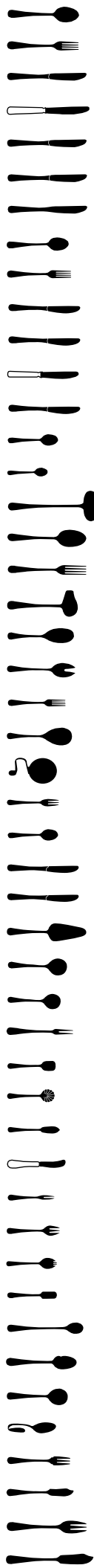

VITTORIALE

1640

PINTI1929

inox 18/10
mm 3,0



SPATEN 1630

PINTI1929

inox 18/10
mm 3,0



Cod.	cm	Euro
0001	20,9	4,38
0002	20,9	4,38
0003	24,0	6,80
00CC	24,5	11,02
00CA	-	-
00L3	-	-
0067	-	-
0004	18,8	4,26
0005	18,6	4,26
0006	21,5	6,70
00L6	-	-
00CD	21,5	10,92
00CB	-	-
0007	14,5	2,18
0008	12,0	2,18
0010	27,5	15,40
0011	24,2	7,60
0012	24,0	7,60
0013	17,8	8,84
0014	-	-
0015	-	-
0016	-	-
0059	-	-
00AW	-	-
0017	16,0	2,82
0018	-	-
00L9	-	-
0019	-	-
0020	24,8	10,62
0052	-	-
00CR	-	-
0009	-	-
0022	-	-
0023	-	-
0025	-	-
00CS	-	-
0026	-	-
0027	-	-
00FM	-	-
0035	-	-
0036	-	-
0038	-	-
0039	-	-
00AT	-	-
0028	18,7	4,58
0029	21,0	4,58
0030	-	-
0031	-	-

Cod.	cm	Euro
0001	23,2	4,26
0002	23,2	4,26
0003	24,5	6,26
00CC	-	-
00CA	-	-
00L3	-	-
0067	-	-
0004	20,0	4,16
0005	20,1	4,16
0006	21,4	6,06
00L6	-	-
00CD	-	-
00CB	-	-
0007	17,2	2,70
0008	11,1	2,60
0010	29,0	15,30
0011	26,0	6,98
0012	26,0	6,98
0013	15,0	8,74
0014	-	-
0015	-	-
0016	-	-
0059	-	-
00AW	-	-
0017	17,2	3,02
0018	-	-
00L9	-	-
0019	-	-
0020	23,0	10,62
0052	-	-
00CR	-	-
0009	-	-
0022	-	-
0023	-	-
0025	-	-
00CS	-	-
0026	-	-
0027	-	-
00FM	-	-
0035	-	-
0036	-	-
0038	-	-
0039	-	-
00AT	-	-
0028	20,0	4,48
0029	22,2	4,48
0030	-	-
0031	-	-

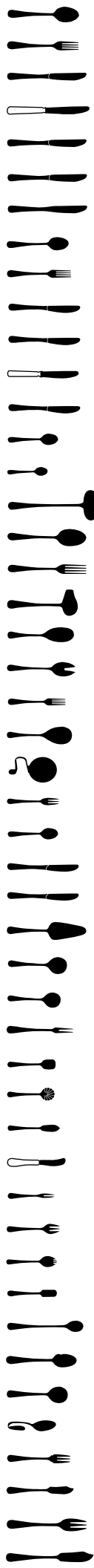

CONCEPT 0450

PINTI1929

inox 18/10
mm 3,0



CONCEPT 0450



Cod. 0011
cm 26,0
cucchiaine servire
serving spoon



Cod. 0012
cm 26,0
forchettone servire
serving fork



Cod. 0003
cm 24,5
coltello tavola
table knife



Cod. 0001
cm 23,2
cucchiaino tavola
table spoon



Cod. 0002
cm 23,2
forchetta tavola
table fork



Cod. 0029
cm 22,2
coltello pesce
fish knife



Cod. 0004
cm 20,0
cucchiaino frutta
dessert spoon



Cod. 0005
cm 20,1
forchetta frutta
dessert fork



Cod. 0006
cm 21,4
coltello frutta
dessert knife



Cod. 0007
cm 17,2
cucchiaino caffè
tea/coffee spoon



Cod. 0028
cm 20,0
forchetta pesce
fish fork



Cod. 0008
cm 11,1
cucchiaino moka
moka spoon



Cod. 0017
cm 17,2
forchetta dolce
pastry fork



Cod. 0010
cm 29,0
mestolo
soup ladle



Cod. 0020
cm 23,0
pala torta
cake server



Cod. 0013
cm 15,0
mestolo salsa
sauce ladle

Cod.	cm	Euro
0001	21,0	3,96
0002	21,0	3,96
0003	23,5	5,20
00CC	-	-
00CA	-	-
00L3	-	-
0067	-	-
0004	18,0	3,86
0005	18,1	3,86
0006	21,2	4,90
00L6	-	-
00CD	-	-
00CB	-	-
0007	14,9	2,96
0008	11,0	2,86
0010	-	-
0011	-	-
0012	-	-
0013	-	-
0014	-	-
0015	-	-
0016	-	-
0059	-	-
00AW	-	-
0017	16,5	2,96
0018	-	-
00L9	-	-
0019	-	-
0020	-	-
0052	-	-
00CR	-	-
0009	-	-
0022	-	-
0023	-	-
0025	19,6	3,96
00CS	-	-
0026	-	-
0027	-	-
00FM	-	-
0035	-	-
0036	-	-
0038	19,2	3,70
0039	18,1	3,66
00AT	-	-
0028	19,0	3,90
0029	21,7	3,90
0030	-	-
0031	-	-

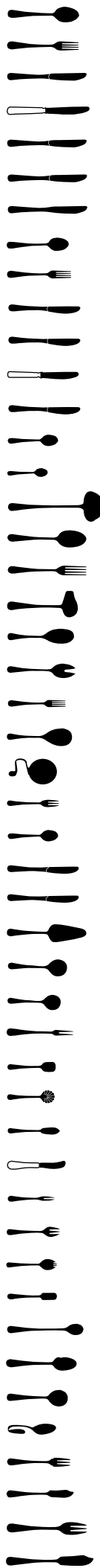

INFINITO 0850

PINTI1929

inox 18/0

forgiato/forged

Design *Daniele Ardisson*

NICKEL
FREE



085000FB cm 18,0 Euro 3,66 cucch. alta cucina alta cucina spoon

INFINITO 0850



Cod. 0001
cm 21,0
cucchiaio tavola
table spoon



Cod. 0002
cm 21,0
forchetta tavola
table fork



Cod. 0003
cm 23,5
coltello tavola
table knife



Cod. 0038
cm 22,1
cucchiaio gourmet
gourmet spoon



Cod. 0028
cm 19,0
forchetta pesce
fish fork



Cod. 0029
cm 21,7
coltello pesce
fish knife



Cod. 0039
cm 18,1
cucchiaio brodo
soup spoon



Cod. 0005
cm 18,1
forchetta frutta
dessert fork



Cod. 0006
cm 21,2
coltello frutta
dessert knife



Cod. 00FB
cm 18,0
cucchiaio alta cucina
alta cucina spoon



Cod. 0017
cm 16,5
forchetta dolce
pastry fork



Cod. 0025
cm 19,6
coltello spalmaburro
butter spreader



Cod. 0004
cm 18,0
cucchiaio frutta
dessert spoon



Cod. 0007
cm 14,9
cucchiaino caffè
tea/coffee spoon



Cod. 0008
cm 11,0
cucchiaino moka
moka spoon

Cod.	cm	Euro
0001	23,0	3,74
0002	23,0	3,74
0003	24,0	6,26
00CC	-	-
00CA	-	-
00L3	-	-
0067	-	-
0004	20,0	3,74
0005	19,9	3,74
0006	21,0	6,06
00L6	-	-
00CD	-	-
00CB	-	-
0007	17,0	2,18
0008	10,9	2,18
0010	29,0	15,40
0011	26,0	6,98
0012	26,0	6,98
0013	15,0	8,84
0014	-	-
0015	-	-
0016	-	-
0059	-	-
00AW	-	-
0017	17,0	2,82
0018	-	-
00L9	-	-
0019	-	-
0020	23,0	10,62
0052	-	-
00CR	15,0	2,18
0009	-	-
0022	-	-
0023	-	-
0025	-	-
00CS	-	-
0026	-	-
0027	-	-
00FM	-	-
0035	-	-
0036	-	-
0038	-	-
0039	-	-
00AT	-	-
0028	19,9	4,06
0029	21,8	4,06
0030	-	-
0031	-	-

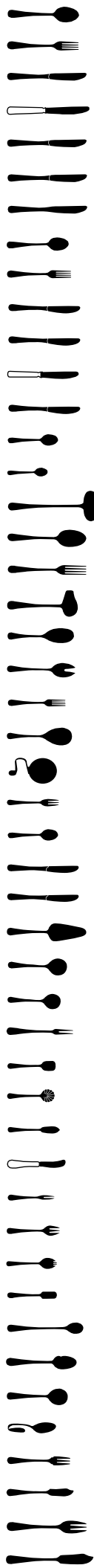

TECNA
0470

PINTI1929

inox 18/10
mm 3,0



TECNA 0470



Cod. 0011
cm 26,0
cucchiaine servire
serving spoon



Cod. 0012
cm 26,0
forchettone servire
serving fork



Cod. 0003
cm 24,0
coltello tavola
table knife



Cod. 0001
cm 23,0
cucchiaino tavola
table spoon



Cod. 0002
cm 23,0
forchetta tavola
table fork



Cod. 0029
cm 21,8
coltello pesce
fish knife



Cod. 0004
cm 20,0
cucchiaino frutta
dessert spoon



Cod. 0005
cm 19,9
forchetta frutta
dessert fork



Cod. 0006
cm 21,0
coltello frutta
dessert knife



Cod. 0007
cm 17,0
cucchiaino caffè
tea/coffee spoon



Cod. 0028
cm 19,9
forchetta pesce
fish fork



Cod. 00CR
cm 15,0
cucchiaino crema
cream spoon



Cod. 0017
cm 17,0
forchetta dolce
pastry fork



Cod. 0008
cm 10,9
cucchiaino moka
moka spoon



Cod. 0010
cm 29,0
mestolo
soup ladle



Cod. 0020
cm 23,0
pala torta
cake server



Cod. 0013
cm 15,0
mestolo salsa
sauce ladle

Cod.	cm	Euro
0001	20,8	3,74
0002	20,9	3,74
0003	22,5	6,26
00CC	-	-
00CA	-	-
00L3	-	-
0067	-	-
0004	18,7	3,74
0005	18,7	3,74
0006	20,5	6,06
00L6	-	-
00CD	-	-
00CB	-	-
0007	14,6	2,08
0008	11,8	1,98
0010	28,0	15,40
0011	25,5	6,98
0012	25,5	6,98
0013	17,4	8,84
0014	-	-
0015	-	-
0016	-	-
0059	-	-
00AW	-	-
0017	15,4	2,82
0018	-	-
00L9	-	-
0019	-	-
0020	23,0	10,62
0052	-	-
00CR	-	-
0009	-	-
0022	-	-
0023	-	-
0025	-	-
00CS	-	-
0026	-	-
0027	-	-
00FM	-	-
0035	-	-
0036	-	-
0038	-	-
0039	-	-
00AT	-	-
0028	18,1	4,06
0029	19,8	4,06
0030	-	-
0031	-	-

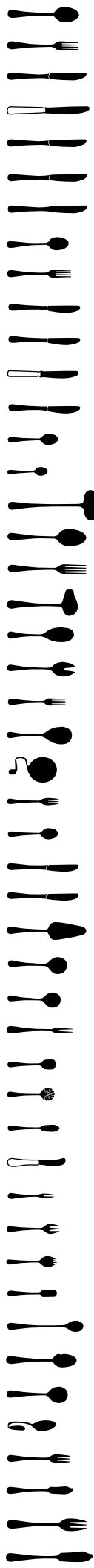

SWING 0880

PINTI1929

inox 18/10
mm 3,0



088000FA 14,6 Euro 2,18 cucch. antipasto piccolo *small starter spoon*
 088000FB 18,7 Euro 3,12 cucch. antipasto grande *large starter spoon*



Cod.	cm	Euro
0001	23,0	3,74
0002	23,0	3,74
0003	24,5	6,26
00CC	-	-
00CA	-	-
00L3	-	-
0067	-	-
0004	19,8	3,74
0005	19,7	3,74
0006	21,4	6,06
00L6	-	-
00CD	-	-
00CB	-	-
0007	16,5	2,18
0008	11,0	2,18
0010	29,0	17,38
0011	26,0	7,80
0012	26,0	7,80
0013	14,9	9,46
0014	26,0	8,94
0015	26,0	8,94
0016	-	-
0059	-	-
00AW	-	-
0017	17,0	2,82
0018	-	-
00L9	-	-
0019	-	-
0020	23,1	10,62
0052	-	-
00CR	-	-
0009	-	-
0022	-	-
0023	-	-
0025	-	-
00CS	-	-
0026	-	-
0027	-	-
00FM	-	-
0035	-	-
0036	-	-
0038	-	-
0039	-	-
00AT	-	-
0028	19,7	4,06
0029	21,8	4,06
0030	-	-
0031	-	-

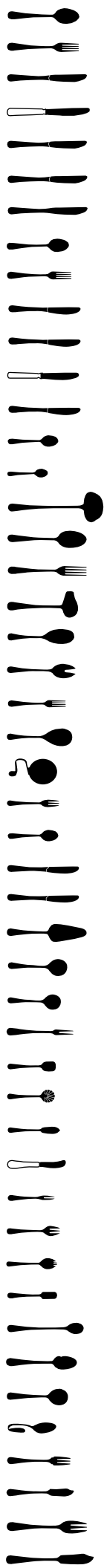

OLIVIA 0490

PINTI1929

inox 18/10
mm 3,0



OLIVIA 0490



Cod. 0011
cm 26,0
cucchiaine servire
serving spoon



Cod. 0012
cm 26,0
forchettone servire
serving fork



Cod. 0003
cm 24,5
coltello tavola
table knife



Cod. 0014
cm 26,0
cucchiaino insalata
salad spoon



Cod. 0015
cm 26,0
forchetta insalata
salad fork



Cod. 0029
cm 21,8
coltello pesce
fish knife



Cod. 0001
cm 23,0
cucchiaino tavola
table spoon



Cod. 0002
cm 23,0
forchetta tavola
table fork



Cod. 0006
cm 21,4
coltello frutta
dessert knife



Cod. 0004
cm 19,8
cucchiaino frutta
dessert spoon



Cod. 0005
cm 19,7
forchetta frutta
dessert fork



Cod. 0007
cm 16,5
cucchiaino caffè
tea/coffee spoon



Cod. 0028
cm 19,7
forchetta pesce
fish fork



Cod. 0008
cm 11
cucchiaino moka
moka spoon



Cod. 0017
cm 17,0
forchetta dolce
pastry fork



Cod. 0010
cm 29,0
mestolo
soup ladle



Cod. 0020
cm 23,1
pala torta
cake server



Cod. 0013
cm 14,9
mestolo salsa
sauce ladle

Cod.	cm	Euro
0001	20,6	3,74
0002	20,6	3,74
0003	24,1	6,26
00CC	25,3	11,02
00CA	-	-
00L3	-	-
0067	23,0	6,26
0004	17,8	3,74
0005	18,5	3,74
0006	22,0	6,06
00L6	-	-
00CD	22,5	10,92
00CB	-	-
0007	14,6	2,08
0008	11,8	1,98
0010	28,0	15,40
0011	23,5	6,98
0012	23,6	6,98
0013	17,5	8,84
0014	-	-
0015	-	-
0016	-	-
0059	-	-
00AW	-	-
0017	15,1	2,82
0018	-	-
00L9	-	-
0019	17,7	4,86
0020	24,0	10,62
0052	-	-
00CR	-	-
0009	-	-
0022	13,7	2,08
0023	-	-
0025	-	-
00CS	-	-
0026	-	-
0027	-	-
00FM	-	-
0035	-	-
0036	-	-
0038	20,4	3,64
0039	17,9	3,64
00AT	-	-
0028	18,0	4,06
0029	19,4	4,06
0030	23,0	6,98
0031	25,0	6,98

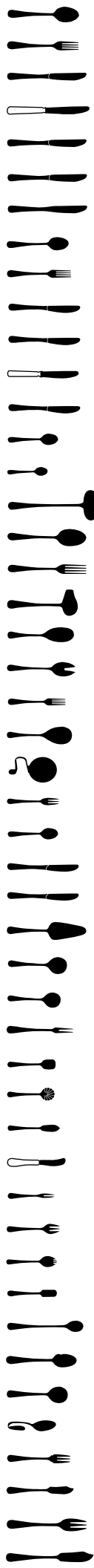

BAGUETTE

0830

PINTI1929

inox 18/10
mm 3,0





Cod.	cm	Euro
0001	20,6	3,74
0002	20,6	3,74
0003	24,0	6,26
00CC	25,2	11,02
00CA	-	-
00L3	-	-
0067	22,8	6,26
0004	17,9	3,74
0005	18,5	3,74
0006	21,6	6,06
00L6	-	-
00CD	21,6	10,92
00CB	-	-
0007	14,6	2,08
0008	11,8	1,98
0010	28,0	15,40
0011	23,5	6,98
0012	23,8	6,98
0013	17,9	8,84
0014	-	-
0015	22,8	8,42
0016	-	-
0059	-	-
00AW	-	-
0017	15,0	2,82
0018	-	-
00L9	-	-
0019	17,6	4,86
0020	24,0	10,62
0052	-	-
00CR	15,2	3,54
0009	19,7	3,74
0022	13,6	2,08
0023	13,5	2,18
0025	15,0	2,64
00CS	-	-
0026	15,3	2,40
0027	15,5	3,02
00FM	-	-
0035	12,1	2,60
0036	22,0	3,02
0038	20,4	3,64
0039	17,8	3,64
00AT	-	-
0028	18,0	4,06
0029	19,6	4,06
0030	22,5	6,98
0031	25,0	6,98

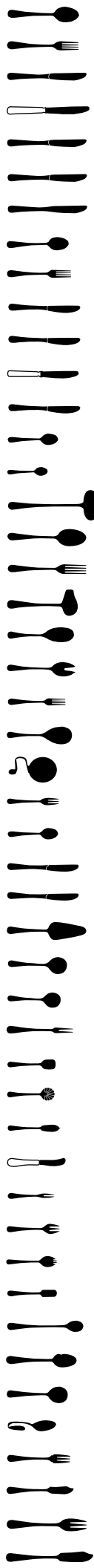

BYRON 0800

PINTI1929

inox 18/10
mm 3,0



BYRON 0800



Cod. 0011
cm 23,5
cucchiaione servire
serving spoon



Cod. 0036
cm 22,0
cucchiaino bibita
long drink spoon



Cod. 0001
cm 20,6
cucchiaino tavola
table spoon



Cod. 0038
cm 20,4
cucchiaino gourmet
gourmet spoon



Cod. 0004
cm 17,9
cucchiaino frutta
dessert spoon



Cod. 0039
cm 17,8
cucchiaino brodo
soup spoon



Cod. 00CR
cm 15,2
cucchiaino crema
cream spoon



Cod. 0007
cm 14,6
cucchiaino caffè
tea/coffee spoon



Cod. 0022
cm 13,6
paletta gelato
ice cream spoon



Cod. 0035
cm 12,1
sessola zucchero
sugar spoon



Cod. 0008
cm 11,8
cucchiaino moka
moka spoon



Cod. 0012
cm 23,8
forchettone servire
serving fork



Cod. 0015
cm 22,8
forchetta insalata
salad fork



Cod. 0030
cm 22,5
forchetta pesce servire
fish serving fork



Cod. 0002
cm 20,6
forchetta tavola
table fork



Cod. 0009
cm 19,7
forchetta carne
meat fork



Cod. 0005
cm 18,5
forchetta frutta
dessert fork



Cod. 0028
cm 18,0
forchetta pesce
fish fork



Cod. 0027
cm 15,5
forchetta ostriche
oyster fork



Cod. 0026
cm 15,3
forchetta lumache
snail fork



Cod. 0017
cm 15,0
forchetta dolce
pastry fork



Cod. 0031
cm 25,0
coltello pesce servire
fish serving knife



Cod. 00CC
cm 25,2
colt. tav. manico vuoto
table knife H. H.



Cod. 0003
cm 24,0
coltello tavola
table knife



Cod. 0067
cm 22,8
coltello bistecca
steak knife



Cod. 00CD
cm 21,6
colt. frutta manico vuoto
dessert knife H. H.



Cod. 0006
cm 21,6
coltello frutta
dessert knife



Cod. 0029
cm 19,6
coltello pesce
fish knife



Cod. 0019
cm 17,6
coltello dolce
pastry knife



Cod. 0025
cm 15,0
spalma burro
butter spreader



Cod. 0010
cm 28,0
mestolo
soup ladle



Cod. 0020
cm 24,0
pala torta
cake server



Cod. 0013
cm 17,9
mestolo salsa
sauce ladle

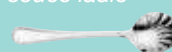

Cod. 0023
cm 13,5
cucchiaino formaggio
grated-cheese spoon

Cod.	cm	Euro
0001	20,8	3,74
0002	20,6	3,74
0003	23,6	6,26
00CC	24,9	11,02
00CA	-	-
00L3	-	-
0067	-	-
0004	18,1	3,74
0005	18,2	3,74
0006	21,2	6,06
00L6	-	-
00CD	22,2	10,92
00CB	-	-
0007	14,6	2,08
0008	11,0	1,98
0010	27,2	15,40
0011	24,1	6,98
0012	24,0	6,98
0013	17,0	8,84
0014	-	-
0015	-	-
0016	-	-
0059	-	-
00AW	-	-
0017	15,5	2,82
0018	-	-
00L9	-	-
0019	-	-
0020	24,0	10,62
0052	-	-
00CR	-	-
0009	-	-
0022	14,2	2,08
0023	-	-
0025	-	-
00CS	-	-
0026	-	-
0027	-	-
00FM	-	-
0035	-	-
0036	-	-
0038	-	-
0039	17,2	3,64
00AT	-	-
0028	18,8	4,06
0029	20,1	4,06
0030	-	-
0031	-	-

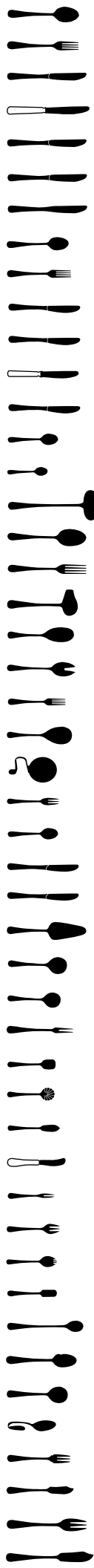

PALLADIUM 0590

PINTI1929

inox 18/10
mm 3,0



EUCLIDE

0480

PINTI1929

inox 18/10

mm 3,0



Cod.	cm	Euro
0001	22,0	3,74
0002	22,0	3,74
0003	24,0	6,26
00CC	-	-
00CA	-	-
00L3	-	-
0067	-	-
0004	-	-
0005	19,3	3,74
0006	21,0	6,06
00L6	-	-
00CD	-	-
00CB	-	-
0007	15,8	2,18
0008	11,0	2,18
0010	29,0	15,40
0011	25,0	6,98
0012	25,0	6,98
0013	-	-
0014	-	-
0015	-	-
0016	-	-
0059	-	-
00AW	-	-
0017	-	-
0018	-	-
00L9	-	-
0019	-	-
0020	-	-
0052	-	-
00CR	-	-
0009	-	-
0022	-	-
0023	-	-
0025	-	-
00CS	-	-
0026	-	-
0027	-	-
00FM	-	-
0035	-	-
0036	-	-
0038	-	-
0039	-	-
00AT	-	-
0028	-	-
0029	-	-
0030	-	-
0031	-	-

Cod.	cm	Euro
0001	20,4	3,74
0002	20,6	3,74
0003	23,2	6,26
00CC	24,5	11,02
00CA	-	-
00L3	-	-
0067	-	-
0004	17,7	3,74
0005	18,4	3,74
0006	21,0	6,06
00L6	-	-
00CD	21,3	10,92
00CB	-	-
0007	14,5	2,08
0008	11,9	1,98
0010	27,7	15,40
0011	23,5	6,98
0012	23,7	6,98
0013	17,4	8,84
0014	-	-
0015	22,8	8,42
0016	-	-
0059	23,8	9,46
00AW	-	-
0017	15,0	2,82
0018	-	-
00L9	-	-
0019	17,7	4,86
0020	24,0	10,62
0052	-	-
00CR	15,5	3,54
0009	19,5	3,74
0022	13,6	2,08
0023	13,5	2,18
0025	15,0	2,64
00CS	18,7	9,56
0026	15,4	2,40
0027	15,5	3,02
00FM	12,5	2,30
0035	12,0	2,60
0036	22,0	3,02
0038	20,4	3,64
0039	17,7	3,64
00AT	-	-
0028	17,8	4,06
0029	19,5	4,06
0030	22,6	6,98
0031	25,1	6,98

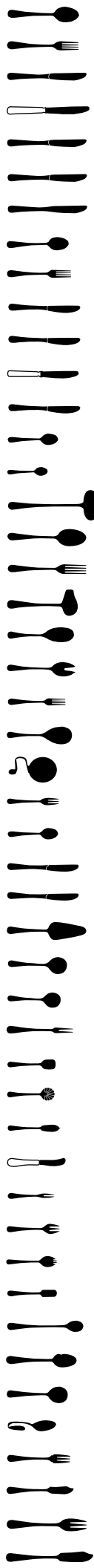

PITAGORA

0810

PINTI1929

inox 18/10
mm 3,0



07600067 Euro 6,16 cm 23,0 colt. bist. profess. *profess. meat knife.*

PITAGORA 0810



Cod. 0059
cm 23,8
cucchiaione risotto
rice spoon



Cod. 0011
cm 23,5
cucchiaione servire
servicing spoon



Cod. 0036
cm 22,0
cucchiaino bibita
long drink spoon



Cod. 0001
cm 20,4
cucchiaio tavola
table spoon



Cod. 0038
cm 20,4
cucchiaio gourmet
gourmet spoon



Cod. 0004
cm 17,7
cucchiaio frutta
dessert spoon



Cod. 0039
cm 17,7
cucchiaio brodo
soup spoon



Cod. 00CR
cm 15,5
cucchiaio crema
cream spoon



Cod. 0007
cm 14,5
cucchiaino caffè
tea/coffee spoon



Cod. 0022
cm 13,6
paletta gelato
ice cream spoon



Cod. 0035
cm 12,0
sessola zucchero
sugar spoon



Cod. 0008
cm 11,9
cucchiaino moka
moka spoon



Cod. 0012
cm 23,7
forchettone servire
servicing fork



Cod. 0015
cm 22,8
forchetta insalata
salad fork



Cod. 0030
cm 22,6
forchetta pesce servire
fish serving fork



Cod. 0002
cm 20,6
forchetta tavola
table fork



Cod. 0009
cm 19,5
forchetta carne
meat fork



Cod. 0005
cm 18,4
forchetta frutta
dessert fork



Cod. 0028
cm 17,8
forchetta pesce
fish fork



Cod. 0027
cm 15,5
forchetta ostriche
oyster fork



Cod. 0026
cm 15,4
forchetta lumache
snail fork



Cod. 0017
cm 15,0
forchetta dolce
pastry fork



Cod. 00FM
cm 12,5
forchetta molluschi
shellfish fork



Cod. 0031
cm 25,1
coltello pesce servire
fish serving knife



Cod. 00CC
cm 24,5
colt. tav manico vuoto
table knife H. H.



Cod. 0003
cm 23,2
coltello tavola
table knife



Cod. 00CD
cm 21,3
colt. frutta manico vuoto
dessert knife H. H.



Cod. 0006
cm 21,0
coltello frutta
dessert knife



Cod. 0029
cm 19,5
coltello pesce
fish knife



Cod. 00CS
cm 18,7
colt. burro manico vuoto
butter spreader H. H.



Cod. 0019
cm 17,7
coltello dolce
pastry knife



Cod. 0025
cm 15,0
spalma burro
butter spreader



Cod. 0010
cm 27,7
mestolo
soup ladle



Cod. 0020
cm 24,0
pala torta
cake server



Cod. 0013
cm 17,4
mestolo salsa
sauce ladle



Cod. 0023
cm 13,5
cucchiaio formaggio
grated-cheese spoon

Cod.	cm	Euro
0001	20,8	3,74
0002	20,7	3,74
0003	24,0	6,26
00CC	23,8	11,02
00CA	-	-
00L3	-	-
0067	23,0	6,26
0004	17,5	3,74
0005	17,7	3,74
0006	21,5	6,06
00L6	-	-
00CD	20,6	10,92
00CB	-	-
0007	14,5	2,08
0008	11,8	1,98
0010	28,0	15,40
0011	23,5	6,98
0012	23,8	6,98
0013	18,0	8,84
0014	-	-
0015	23,0	8,84
0016	-	-
0059	-	-
00AW	-	-
0017	16,7	2,82
0018	-	-
00L9	-	-
0019	-	-
0020	23,2	10,62
0052	-	-
00CR	-	-
0009	-	-
0022	-	-
0023	-	-
0025	-	-
00CS	-	-
0026	-	-
0027	-	-
00FM	-	-
0035	-	-
0036	-	-
0038	-	-
0039	17,3	3,64
00AT	-	-
0028	19,5	4,06
0029	21,3	4,06
0030	-	-
0031	-	-

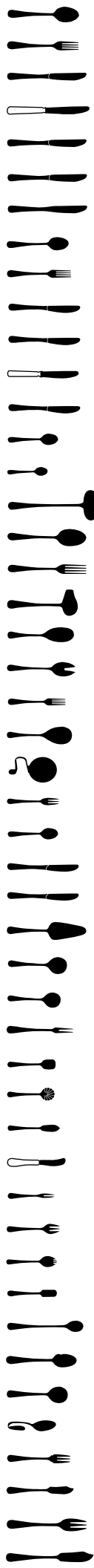

LEONARDO 0500

PINTI1929

inox 18/10
mm 3,0





Cod.	cm	Euro
0001	20,8	3,86
0002	20,8	3,86
0003	23,5	6,26
00CC	23,8	11,02
00CA	-	-
00L3	-	-
0067	23,6	6,26
0004	18,7	3,86
0005	18,7	3,86
0006	21,15	6,06
00L6	-	-
00CD	21,5	10,92
00CB	-	-
0007	14,7	2,40
0008	10,7	2,18
0010	27,4	15,40
0011	23,5	7,50
0012	23,8	7,50
0013	17,6	8,94
0014	-	-
0015	-	-
0016	-	-
0059	-	-
00AW	-	-
0017	15,5	2,60
0018	-	-
00L9	-	-
0019	-	-
0020	23,5	11,44
0052	-	-
00CR	-	-
0009	-	-
0022	-	-
0023	-	-
0025	-	-
00CS	-	-
0026	-	-
0027	-	-
00FM	-	-
0035	-	-
0036	-	-
0038	-	-
0039	18,1	3,74
00AT	-	-
0028	18,7	3,74
0029	19,8	3,74
0030	-	-
0031	-	-

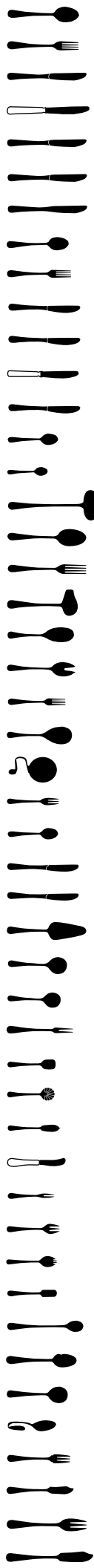

MILLENNIUM 2270

PINTINOX

inox 18/10
mm 4,0



RITZ 2280

PINTINOX

inox 18/10
mm 4,0



Cod.	cm	Euro
0001	20,8	3,86
0002	20,8	3,86
0003	23,5	6,26
00CC	24,0	11,02
00CA	-	-
00L3	-	-
0067	22,8	6,26
0004	17,8	3,86
0005	18,1	3,86
0006	21,15	6,06
00L6	-	-
00CD	21,5	10,92
00CB	-	-
0007	14,3	2,40
0008	11,1	2,18
0010	27,5	15,40
0011	24,0	7,50
0012	24,0	7,50
0013	17,0	8,94
0014	-	-
0015	-	-
0016	-	-
0059	-	-
00AW	-	-
0017	14,8	2,60
0018	-	-
00L9	-	-
0019	-	-
0020	23,6	11,44
0052	-	-
00CR	-	-
0009	-	-
0022	13,8	2,40
0023	-	-
0025	-	-
00CS	-	-
0026	-	-
0027	-	-
00FM	-	-
0035	-	-
0036	19,5	2,82
0038	-	-
0039	17,8	3,74
00AT	-	-
0028	19,0	3,74
0029	19,7	3,74
0030	-	-
0031	-	-

Cod.	cm	Euro
0001	21,0	3,20
0002	21,0	3,20
0003	22,5	5,10
00CC	-	-
00CA	-	-
00L3	-	-
0067	-	-
0004	18,0	3,18
0005	18,0	3,18
0006	19,2	4,90
00L6	-	-
00CD	-	-
00CB	-	-
0007	14,7	2,10
0008	11,0	2,08
0010	29,0	16,70
0011	26,0	7,50
0012	26,0	7,50
0013	-	-
0014	-	-
0015	-	-
0016	-	-
0059	-	-
00AW	-	-
0017	15,2	2,50
0018	-	-
00L9	-	-
0019	-	-
0020	-	-
0052	-	-
00CR	-	-
0009	-	-
0022	-	-
0023	-	-
0025	-	-
00CS	-	-
0026	-	-
0027	-	-
00FM	-	-
0035	-	-
0036	-	-
0038	-	-
0039	-	-
00AT	-	-
0028	19,1	3,60
0029	20,5	3,60
0030	-	-
0031	-	-

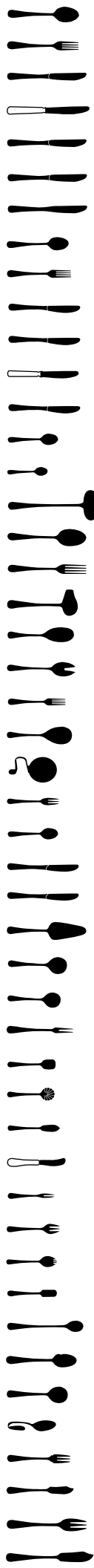

STILE 2400

PINTINOX

inox 18/10
mm 4,0

NEW





Cod.	cm	Euro
0001	21,0	2,60
0002	20,9	2,60
0003	23,0	5,72
00CC	-	-
00CA	-	-
00L3	-	-
0067	23,0	5,72
0004	-	-
0005	18,0	2,60
0006	21,0	5,72
00L6	-	-
00CD	-	-
00CB	-	-
0007	15,0	1,66
0008	11,0	1,56
0010	29,0	13,94
0011	25,0	5,82
0012	25,0	5,82
0013	-	-
0014	-	-
0015	-	-
0016	-	-
0059	-	-
00AW	-	-
0017	-	-
0018	-	-
00L9	-	-
0019	-	-
0020	-	-
0052	-	-
00CR	-	-
0009	-	-
0022	-	-
0023	-	-
0025	-	-
00CS	-	-
0026	-	-
0027	-	-
00FM	-	-
0035	-	-
0036	-	-
0038	-	-
0039	-	-
00AT	-	-
0028	20,0	3,22
0029	22,0	3,22
0030	-	-
0031	-	-

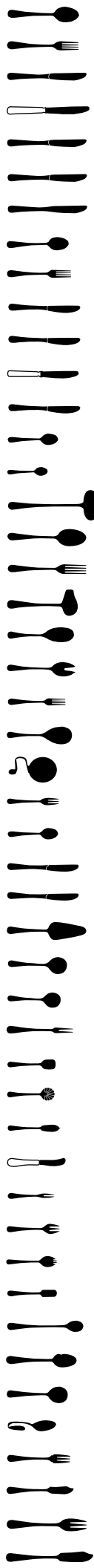

CARLTON 1780

PINTINOX

inox 18/10
mm 3,0



SETTECENTO

2050

PINTINOX

inox 18/10

mm 3,0



Cod.	cm	Euro
0001	20,1	3,22
0002	20,1	3,22
0003	22,7	5,62
00CC	25,0	11,02
00CA	-	-
00L3	-	-
0067	-	-
0004	17,1	3,12
0005	17,1	3,12
0006	20,2	5,52
00L6	-	-
00CD	22,5	10,92
00CB	-	-
0007	14,6	1,78
0008	11,8	1,78
0010	28,0	14,56
0011	23,1	6,14
0012	23,6	6,14
0013	16,5	7,80
0014	-	-
0015	-	-
0016	-	-
0059	-	-
00AW	-	-
0017	14,8	1,98
0018	-	-
00L9	-	-
0019	-	-
0020	22,7	10,10
0052	-	-
00CR	-	-
0009	-	-
0022	-	-
0023	-	-
0025	-	-
00CS	-	-
0026	-	-
0027	-	-
00FM	-	-
0035	-	-
0036	-	-
0038	-	-
0039	16,9	3,02
00AT	-	-
0028	19,4	3,54
0029	20,9	3,54
0030	-	-
0031	-	-

Cod.	cm	Euro
0001	20,8	3,16
0002	20,8	3,16
0003	23,0	5,30
00CC	-	-
00CA	-	-
00L3	-	-
0067	-	-
0004	18,7	3,16
0005	18,7	3,16
0006	21,15	5,30
00L6	-	-
00CD	-	-
00CB	-	-
0007	14,4	1,68
0008	11,6	1,68
0010	29,0	14,08
0011	24,0	5,68
0012	23,5	5,68
0013	18,8	6,42
0014	-	-
0015	-	-
0016	-	-
0059	-	-
00AW	-	-
0017	15,3	2,10
0018	-	-
00L9	-	-
0019	-	-
0020	24,0	7,04
0052	-	-
00CR	-	-
0009	-	-
0022	-	-
0023	-	-
0025	-	-
00CS	-	-
0026	-	-
0027	-	-
00FM	-	-
0035	-	-
0036	-	-
0038	-	-
0039	-	-
00AT	-	-
0028	18,7	3,16
0029	19,8	3,24
0030	-	-
0031	-	-

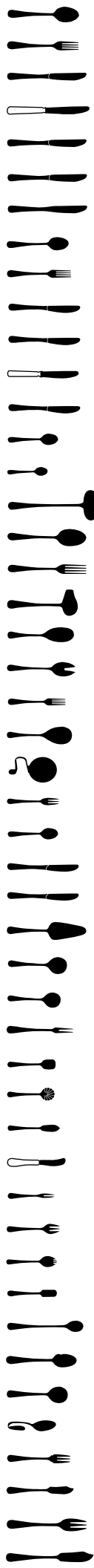

ROMANINO 0650

PINTINOX

inox 18/10
mm 3,5





Cod.	cm	Euro
0001	20,4	3,08
0002	20,4	3,08
0003	23,0	4,22
00CC	-	-
00CA	-	-
00L3	-	-
0067	-	-
0004	18,0	2,98
0005	18,0	2,98
0006	20,0	4,22
00L6	-	-
00CD	-	-
00CB	-	-
0007	13,7	2,24
0008	11,0	2,12
0010	-	-
0011	-	-
0012	-	-
0013	-	-
0014	-	-
0015	-	-
0016	-	-
0059	-	-
00AW	-	-
0017	-	-
0018	-	-
00L9	-	-
0019	-	-
0020	-	-
0052	-	-
00CR	-	-
0009	-	-
0022	-	-
0023	-	-
0025	-	-
00CS	-	-
0026	-	-
0027	-	-
00FM	-	-
0035	-	-
0036	-	-
0038	-	-
0039	-	-
00AT	-	-
0028	-	-
0029	-	-
0030	-	-
0031	-	-

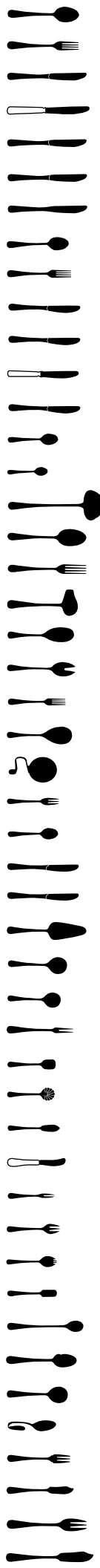

TRUMPET 2070

PINTINOX

inox 18/0

forgiato - forged

Design Daniele Ardisson

NICKEL
FREE



BERNINI 2060

PINTINOX

inox 18/10

mm 3,0



Cod.	cm	Euro
0001	20,0	3,02
0002	20,0	3,02
0003	22,5	5,30
00CC	25,0	11,02
00CA	-	-
00L3	-	-
0067	-	-
0004	17,1	3,02
0005	17,1	3,02
0006	20,0	5,30
00L6	-	-
00CD	24,4	10,92
00CB	-	-
0007	14,3	1,78
0008	11,5	1,78
0010	26,5	14,56
0011	23,1	6,14
0012	23,5	6,14
0013	16,5	7,80
0014	-	-
0015	22,8	7,60
0016	-	-
0059	-	-
00AW	-	-
0017	15,0	1,98
0018	-	-
00L9	-	-
0019	-	-
0020	22,7	10,10
0052	-	-
00CR	-	-
0009	-	-
0022	-	-
0023	-	-
0025	-	-
00CS	-	-
0026	-	-
0027	-	-
00FM	-	-
0035	-	-
0036	-	-
0038	-	-
0039	-	-
00AT	-	-
0028	19,4	3,44
0029	20,9	3,44
0030	-	-
0031	-	-

Cod.	cm	Euro
0001	21,2	3,02
0002	21,0	3,02
0003	23,0	5,30
00CC	-	-
00CA	-	-
00L3	-	-
0067	-	-
0004	18,1	3,02
0005	18,0	3,02
0006	20,0	5,30
00L6	-	-
00CD	-	-
00CB	-	-
0007	15,1	1,88
0008	11,1	1,88
0010	29,0	16,74
0011	24,0	6,56
0012	24,0	6,56
0013	16,5	8,94
0014	-	-
0015	-	-
0016	-	-
0059	-	-
00AW	-	-
0017	17,0	2,70
0018	-	-
00L9	-	-
0019	-	-
0020	24,0	10,10
0052	-	-
00CR	-	-
0009	-	-
0022	-	-
0023	-	-
0025	-	-
00CS	-	-
0026	-	-
0027	-	-
00FM	-	-
0035	-	-
0036	-	-
0038	-	-
0039	-	-
00AT	-	-
0028	19,5	3,02
0029	21,5	3,02
0030	-	-
0031	-	-

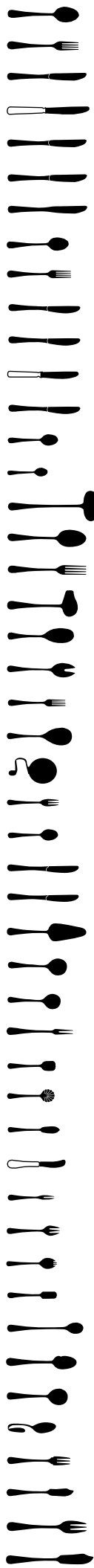

LIBERTY

1660

PINTINOX

inox 18/10
mm 3,0



LIBERTY 1660



Cod. 0011
cm 24,0
cucchiaine servire
serving spoon



Cod. 0012
cm 24,0
forchettone servire
serving fork



Cod. 0003
cm 23,0
coltello tavola
table knife



Cod. 0001
cm 21,2
cucchiaino tavola
table spoon



Cod. 0002
cm 21,0
forchetta tavola
table fork



Cod. 0029
cm 21,5
coltello pesce
fish knife



Cod. 0004
cm 18,1
cucchiaino frutta
dessert spoon



Cod. 0028
cm 19,5
forchetta pesce
fish fork



Cod. 0006
cm 20,0
coltello frutta
dessert knife



Cod. 0007
cm 15,1
cucchiaino caffè
tea/coffee spoon



Cod. 0005
cm 18,0
forchetta frutta
dessert fork



Cod. 0008
cm 11,1
cucchiaino moka
moka spoon



Cod. 0017
cm 17,0
forchetta dolce
pastry fork



Cod. 0010
cm 29,0
mestolo
soup ladle



Cod. 0020
cm 24,0
pala torta
cake server



Cod. 0013
cm 16,5
mestolo salsa
sauce ladle

Cod.	cm	Euro
0001	21,0	2,92
0002	21,0	2,92
0003	23,4	5,30
00CC	23,8	11,02
00CA	-	-
00L3	-	-
0067	23,0	5,30
0004	18,2	2,92
0005	18,2	2,92
0006	21,0	5,30
00L6	-	-
00CD	21,5	10,92
00CB	-	-
0007	14,7	1,78
0008	10,8	1,78
0010	28,8	16,74
0011	24,1	6,56
0012	24,1	6,56
0013	14,0	8,94
0014	25,0	6,76
0015	25,0	6,76
0016	-	-
0059	26,0	9,68
00AW	-	-
0017	14,6	1,98
0018	-	-
00L9	-	-
0019	-	-
0020	22,9	10,10
0052	-	-
00CR	-	-
0009	15,0	1,98
0022	14,5	1,78
0023	-	-
0025	18,0	5,26
00CS	-	-
0026	-	-
0027	14,5	1,98
00FM	-	-
0035	-	-
0036	22,0	2,40
0038	21,5	2,92
0039	18,5	2,92
00AT	-	-
0028	18,2	2,92
0029	20,3	2,92
0030	-	-
0031	-	-

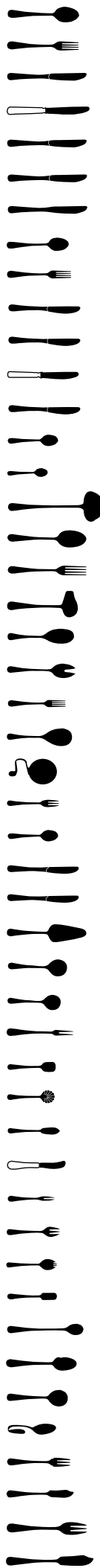

PALACE 1690

PINTINOX

inox 18/10
mm 3,0



169000D3 Euro 5,72 cm 23,0 coltello verticale *standing knife*

PALACE 1690



Cod. 0059
cm 26,0
cucchiaione risotto
rice spoon



Cod. 0014
cm 25,0
cucchiaio insalata
salad spoon



Cod. 0011
cm 24,1
cucchiaione servire
servicing spoon



Cod. 0036
cm 22,0
cucchiaino bibita
long drink spoon



Cod. 0038
cm 21,5
cucchiaio gourmet
gourmet spoon



Cod. 0001
cm 21,0
cucchiaio tavola
table spoon



Cod. 0039
cm 18,5
cucchiaio brodo
soup spoon



Cod. 0004
cm 18,2
cucchiaino frutta
dessert spoon



Cod. 0007
cm 14,7
cucchiaino caffè
tea/coffee spoon



Cod. 0022
cm 14,5
paletta gelato
ice cream spoon



Cod. 0008
cm 10,8
cucchiaino moka
moka spoon



Cod. 0015
cm 25,0
forchetta insalata
salad fork



Cod. 0012
cm 24,1
forchettone servire
servicing fork



Cod. 0002
cm 21,0
forchetta tavola
table fork



Cod. 0005
cm 18,2
forchetta frutta
dessert fork



Cod. 0028
cm 18,2
forchetta pesce
fish fork



Cod. 0009
cm 15,0
forchetta carne
meat fork



Cod. 0017
cm 14,6
forchetta dolce
pastry fork



Cod. 0027
cm 14,5
forchetta ostriche
oyster fork



Cod. 0003
cm 23,4
coltello tavola
table knife



Cod. 00D3
cm 23,0
coltello verticale
standing knife



Cod. 0067
cm 23,0
coltello bistecca
steak knife



Cod. 0006
cm 21,0
coltello frutta
dessert knife



Cod. 0029
cm 20,3
coltello pesce
fish knife



Cod. 0025
cm 18,0
spalma burro
butter spreader



Cod. 0010
cm 28,8
mestolo
soup ladle



Cod. 0020
cm 22,9
pala torta
cake server



Cod. 0013
cm 14,0
mestolo salsa
sauce ladle

Cod.	cm	Euro
0001	19,5	2,92
0002	19,5	2,92
0003	21,6	4,98
00CC	-	-
00CA	-	-
00L3	-	-
0067	-	-
0004	16,6	2,92
0005	16,6	2,92
0006	19,8	4,98
00L6	-	-
00CD	-	-
00CB	-	-
0007	13,8	1,66
0008	11,6	1,66
0010	27,0	14,56
0011	22,8	6,56
0012	22,8	6,56
0013	16,7	7,70
0014	-	-
0015	22,5	8,02
0016	-	-
0059	-	-
00AW	-	-
0017	14,6	1,98
0018	-	-
00L9	-	-
0019	-	-
0020	23,2	10,10
0052	-	-
00CR	-	-
0009	-	-
0022	-	-
0023	-	-
0025	-	-
00CS	-	-
0026	-	-
0027	-	-
00FM	-	-
0035	-	-
0036	-	-
0038	-	-
0039	17,2	2,70
00AT	-	-
0028	19,2	3,34
0029	20,7	3,34
0030	-	-
0031	-	-

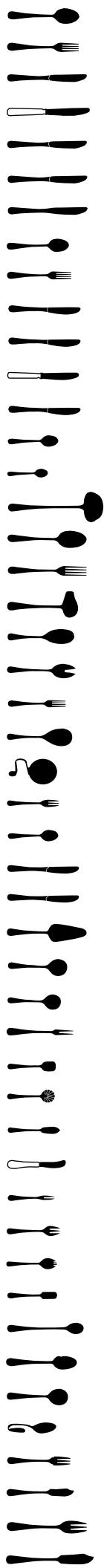

CASALI 2100

PINTINOX

inox 18/10
mm 3,0



SAVOY 1700

PINTINOX

inox 18/10

mm 3,0



Cod.	cm	Euro
0001	20,8	2,92
0002	20,9	2,92
0003	23,0	5,30
00CC	24,5	11,02
00CA	-	-
00L3	-	-
0067	-	-
0004	18,0	2,92
0005	18,1	2,92
0006	20,0	5,30
00L6	-	-
00CD	21,3	10,92
00CB	-	-
0007	14,9	1,78
0008	11,0	1,78
0010	28,0	16,74
0011	25,5	6,56
0012	25,5	6,56
0013	17,4	8,94
0014	-	-
0015	-	-
0016	-	-
0059	-	-
00AW	-	-
0017	16,1	1,98
0018	-	-
00L9	-	-
0019	-	-
0020	23,0	10,10
0052	-	-
00CR	-	-
0009	-	-
0022	-	-
0023	-	-
0025	-	-
00CS	-	-
0026	-	-
0027	-	-
00FM	-	-
0035	-	-
0036	-	-
0038	-	-
0039	-	-
00AT	-	-
0028	18,1	2,92
0029	20,0	2,92
0030	-	-
0031	-	-

Cod.	cm	Euro
0001	21,0	2,80
0002	20,8	2,80
0003	23,3	5,30
00CC	-	-
00CA	-	-
00L3	-	-
0067	23,3	5,30
0004	18,0	2,78
0005	18,0	2,78
0006	21,2	5,30
00L6	-	-
00CD	-	-
00CB	-	-
0007	15,0	1,90
0008	11,0	1,80
0010	29,0	13,40
0011	25,0	5,60
0012	25,0	5,60
0013	-	-
0014	-	-
0015	-	-
0016	-	-
0059	-	-
00AW	-	-
0017	-	-
0018	-	-
00L9	-	-
0019	-	-
0020	-	-
0052	-	-
00CR	-	-
0009	-	-
0022	-	-
0023	-	-
0025	-	-
00CS	-	-
0026	-	-
0027	-	-
00FM	-	-
0035	-	-
0036	-	-
0038	-	-
0039	-	-
00AT	-	-
0028	19,7	3,00
0029	21,8	3,00
0030	-	-
0031	-	-

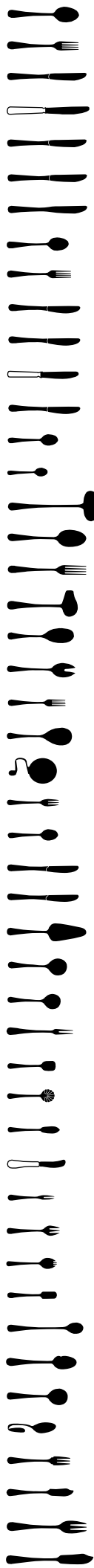

EXCELSIOR 1460

PINTINOX

inox 18/10
mm 3,0

NEW





Cod.	cm	Euro
0001	21,2	2,70
0002	21,2	2,70
0003	23,0	5,30
00CC	-	-
00CA	-	-
00L3	-	-
0067	-	-
0004	18,0	2,70
0005	18,0	2,70
0006	20,0	5,30
00L6	-	-
00CD	-	-
00CB	-	-
0007	15,0	1,66
0008	11,0	1,66
0010	28,6	14,56
0011	24,0	6,56
0012	24,0	6,56
0013	16,4	7,60
0014	-	-
0015	-	-
0016	-	-
0059	-	-
00AW	-	-
0017	16,1	1,98
0018	-	-
00L9	-	-
0019	-	-
0020	24,3	10,10
0052	-	-
00CR	-	-
0009	-	-
0022	-	-
0023	-	-
0025	-	-
00CS	-	-
0026	-	-
0027	-	-
00FM	-	-
0035	-	-
0036	-	-
0038	-	-
0039	-	-
00AT	-	-
0028	18,0	2,70
0029	19,9	2,70
0030	-	-
0031	-	-

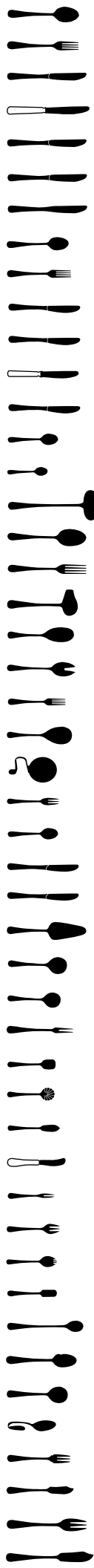

TREND 1670

PINTINOX

inox 18/10
mm 3,0



EXPO

2040

PINTINOX

inox 18/10

mm 2,5



Cod.	cm	Euro
0001	20,6	2,70
0002	20,9	2,70
0003	24,3	5,62
00CC	-	-
00CA	-	-
00L3	-	-
0067	-	-
0004	18,5	2,60
0005	18,9	2,60
0006	21,4	5,52
00L6	-	-
00CD	-	-
00CB	-	-
0007	15,0	1,56
0008	11,6	1,56
0010	28,2	13,94
0011	23,9	5,82
0012	24,0	5,82
0013	17,6	7,28
0014	-	-
0015	-	-
0016	-	-
0059	-	-
00AW	-	-
0017	15,2	1,88
0018	-	-
00L9	-	-
0019	-	-
0020	23,8	7,28
0052	-	-
00CR	-	-
0009	-	-
0022	-	-
0023	-	-
0025	-	-
00CS	-	-
0026	-	-
0027	-	-
00FM	-	-
0035	-	-
0036	-	-
0038	-	-
0039	-	-
00AT	-	-
0028	18,9	3,22
0029	19,7	3,22
0030	-	-
0031	-	-

Cod.	cm	Euro
0001	21,0	2,60
0002	21,2	2,60
0003	22,5	4,86
00CC	-	-
00CA	-	-
00L3	-	-
0067	22,5	4,22
0004	18,3	2,60
0005	18,2	2,60
0006	20,1	4,86
00L6	-	-
00CD	-	-
00CB	-	-
0007	14,8	1,56
0008	10,9	1,56
0010	26,9	15,40
0011	24,9	6,14
0012	25,1	6,14
0013	16,4	7,60
0014	-	-
0015	-	-
0016	-	-
0059	-	-
00AW	-	-
0017	16,1	1,78
0018	-	-
00L9	-	-
0019	-	-
0020	22,8	7,28
0052	-	-
00CR	-	-
0009	-	-
0022	-	-
0023	-	-
0025	-	-
00CS	-	-
0026	-	-
0027	-	-
00FM	-	-
0035	-	-
0036	22,1	2,40
0038	-	-
0039	-	-
00AT	-	-
0028	18,5	2,60
0029	20,7	2,60
0030	-	-
0031	-	-

SYNTHESIS 2030

PINTINOX

inox 18/10
mm 3,0



203000D3 Euro 4,86 cm 22,6 coltello curvo *curved knife*

SYNTHESIS 2030



Cod. 0011
cm 24,9
cucchiaine servire
serving spoon



Cod. 0012
cm 25,1
forchettone servire
serving fork



Cod. 00D3
cm 22,6
coltello curvo
curved knife



Cod. 0036
cm 22,1
cucchiaino bibita
long drink spoon



Cod. 0002
cm 21,2
forchetta tavola
table fork



Cod. 0003
cm 22,5
coltello tavola
table knife



Cod. 0001
cm 21,0
cucchiaino tavola
table spoon



Cod. 0028
cm 18,5
forchetta pesce
fish fork



Cod. 0067
cm 22,5
coltello bistecca
steak knife



Cod. 0004
cm 18,3
cucchiaino frutta
dessert spoon



Cod. 0005
cm 18,2
forchetta frutta
dessert fork



Cod. 0029
cm 20,7
coltello pesce
fish knife



Cod. 0007
cm 14,8
cucchiaino caffè
tea/coffee spoon



Cod. 0017
cm 16,1
forchetta dolce
pastry fork



Cod. 0006
cm 20,1
coltello frutta
dessert knife



Cod. 0008
cm 10,9
cucchiaino moka
moka spoon



Cod. 0010
cm 26,9
mestolo
soup ladle



Cod. 0020
cm 22,8
pala torta
cake server



Cod. 0013
cm 16,4
mestolo salsa
sauce ladle

Cod.	cm	Euro
0001	20,0	2,66
0002	20,0	2,66
0003	22,0	3,68
00CC	-	-
00CA	-	-
00L3	-	-
0067	-	-
0004	18,0	2,66
0005	18,0	2,66
0006	20,0	3,68
00L6	-	-
00CD	-	-
00CB	-	-
0007	14,0	2,24
0008	11,0	2,12
0010	-	-
0011	-	-
0012	-	-
0013	-	-
0014	-	-
0015	-	-
0016	-	-
0059	-	-
00AW	-	-
0017	-	-
0018	-	-
00L9	-	-
0019	-	-
0020	-	-
0052	-	-
00CR	-	-
0009	-	-
0022	-	-
0023	-	-
0025	-	-
00CS	-	-
0026	-	-
0027	-	-
00FM	-	-
0035	-	-
0036	-	-
0038	-	-
0039	-	-
00AT	-	-
0028	-	-
0029	-	-
0030	-	-
0031	-	-

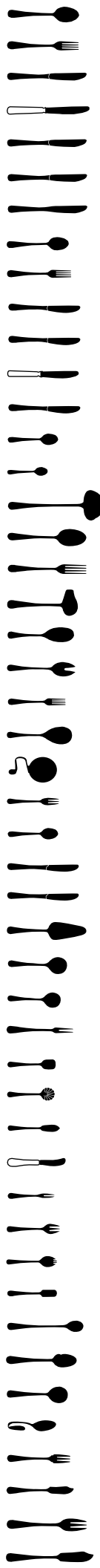

TIE 2080

PINTINOX

inox 18/0

forgiato - *forged*

Design *Daniele Ardisson*

NICKEL
FREE



SOLARIS

2170

PINTINOX

inox 18/10

mm 2,5



Cod.	cm	Euro
0001	19,7	2,60
0002	20,0	2,60
0003	21,5	4,86
00CC	-	-
00CA	-	-
00L3	-	-
0067	-	-
0004	18,1	2,60
0005	17,6	2,60
0006	18,4	4,86
00L6	-	-
00CD	-	-
00CB	-	-
0007	13,8	1,66
0008	12,1	1,56
0010	27,2	13,94
0011	22,3	5,82
0012	22,4	5,82
0013	17,8	7,60
0014	-	-
0015	22,3	7,08
0016	-	-
0059	-	-
00AW	-	-
0017	15,7	1,88
0018	-	-
00L9	-	-
0019	-	-
0020	23,6	7,28
0052	-	-
00CR	-	-
0009	-	-
0022	-	-
0023	-	-
0025	-	-
00CS	-	-
0026	-	-
0027	-	-
00FM	-	-
0035	-	-
0036	-	-
0038	-	-
0039	-	-
00AT	-	-
0028	19,1	3,22
0029	19,4	3,22
0030	-	-
0031	-	-

Cod.	cm	Euro
0001	20,6	2,60
0002	20,6	2,60
0003	24,1	5,72
00CC	25,0	11,02
00CA	23,5	5,18
00L3	22,0	2,38
0067	-	-
0004	18,5	2,60
0005	18,5	2,60
0006	22,0	5,72
00L6	19,4	2,38
00CD	22,0	10,92
00CB	21,4	5,08
0007	14,6	1,66
0008	11,6	1,56
0010	27,2	13,94
0011	23,2	5,82
0012	23,6	5,82
0013	17,5	7,60
0014	-	-
0015	22,3	7,28
0016	14,7	1,98
0059	-	-
00AW	-	-
0017	15,2	1,88
0018	-	-
00L9	-	-
0019	17,8	4,44
0020	23,7	7,28
0052	-	-
00CR	-	-
0009	-	-
0022	13,7	1,66
0023	-	-
0025	-	-
00CS	-	-
0026	-	-
0027	-	-
00FM	12,5	1,88
0035	-	-
0036	-	-
0038	-	-
0039	17,9	2,50
00AT	-	-
0028	18,0	3,22
0029	19,4	3,22
0030	22,7	5,82
0031	25,1	5,82

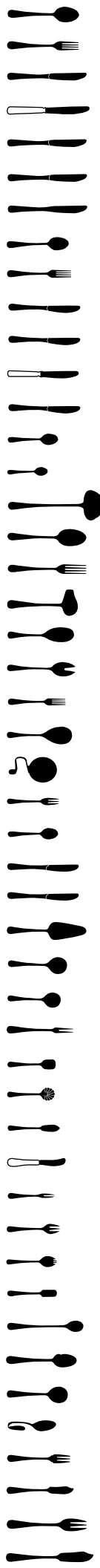

SIRIO 2260

PINTINOX

inox 18/10
mm 2,5





Cod.	cm	Euro
0001	20,6	2,60
0002	20,6	2,60
0003	24,1	5,72
00CC	25,3	11,02
00CA	-	-
00L3	-	-
0067	-	-
0004	18,5	2,60
0005	18,5	2,60
0006	22,0	5,72
00L6	-	-
00CD	22,5	10,92
00CB	-	-
0007	14,6	1,66
0008	11,8	1,56
0010	28,0	13,94
0011	23,5	5,82
0012	23,6	5,82
0013	17,5	7,60
0014	-	-
0015	-	-
0016	-	-
0059	-	-
00AW	-	-
0017	15,1	1,88
0018	-	-
00L9	-	-
0019	-	-
0020	24,0	7,28
0052	-	-
00CR	-	-
0009	-	-
0022	-	-
0023	-	-
0025	-	-
00CS	-	-
0026	-	-
0027	-	-
00FM	-	-
0035	-	-
0036	-	-
0038	-	-
0039	-	-
00AT	-	-
0028	18,0	3,22
0029	19,4	3,22
0030	-	-
0031	-	-

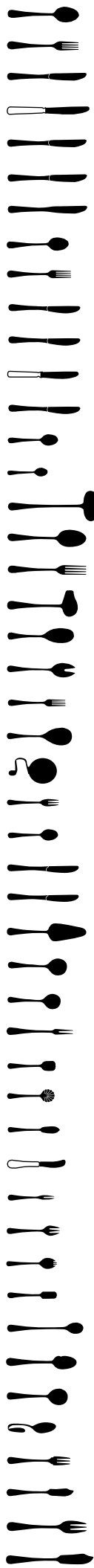

ROMA 2200

PINTINOX

inox 18/10
mm 2,5



FILET

0540

PINTINOX

inox 18/10

mm 2,5



Cod.	cm	Euro
0001	20,9	2,60
0002	20,7	2,60
0003	23,4	5,72
00CC	23,4	11,02
00CA	-	-
00L3	-	-
0067	-	-
0004	18,5	2,60
0005	18,5	2,60
0006	21,5	5,72
00L6	-	-
00CD	21,5	10,92
00CB	-	-
0007	14,6	1,66
0008	12,0	1,56
0010	27,5	13,94
0011	24,0	5,82
0012	24,1	5,82
0013	18,0	7,60
0014	-	-
0015	-	-
0016	-	-
0059	-	-
00AW	-	-
0017	15,2	1,88
0018	-	-
00L9	-	-
0019	-	-
0020	24,0	7,28
0052	-	-
00CR	-	-
0009	-	-
0022	13,6	1,66
0023	-	-
0025	-	5,58
00CS	-	-
0026	-	-
0027	-	-
00FM	-	-
0035	-	-
0036	-	-
0038	20,4	2,50
0039	-	-
00AT	-	-
0028	18,0	3,22
0029	19,6	3,22
0030	-	-
0031	-	-

Cod.	cm	Euro
0001	20,6	2,60
0002	20,9	2,60
0003	22,6	5,30
00CC	-	-
00CA	-	-
00L3	-	-
0067	22,5	5,30
0004	18,3	2,60
0005	18,5	2,60
0006	19,9	5,30
00L6	-	-
00CD	-	-
00CB	-	-
0007	15,1	1,56
0008	11,6	1,56
0010	29,3	13,94
0011	25,3	5,82
0012	23,5	5,82
0013	17,1	7,28
0014	-	-
0015	-	-
0016	-	-
0059	-	-
00AW	-	-
0017	15,3	1,88
0018	-	-
00L9	-	-
0019	-	-
0020	23,9	7,28
0052	-	-
00CR	-	-
0009	-	-
0022	-	-
0023	-	-
0025	-	-
00CS	-	-
0026	-	-
0027	-	-
00FM	-	-
0035	-	-
0036	-	-
0038	-	-
0039	-	-
00AT	-	-
0028	18,6	3,22
0029	19,6	3,22
0030	-	-
0031	-	-

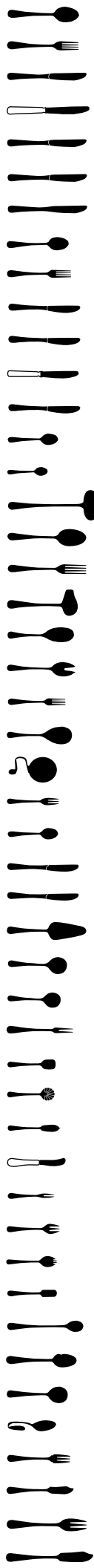

SABRINA 2090

PINTINOX

inox 18/10
mm 2,5



SUPERAMERICA

2380

PINTINOX

inox 18/10

mm 2,5



Cod.	cm	Euro
0001	20,8	2,50
0002	20,8	2,50
0003	23,0	4,64
00CC	-	-
00CA	-	-
00L3	-	-
0067	-	-
0004	-	-
0005	-	-
0006	-	-
00L6	-	-
00CD	-	-
00CB	-	-
0007	-	-
0008	-	-
0010	-	-
0011	-	-
0012	-	-
0013	-	-
0014	-	-
0015	-	-
0016	-	-
0059	-	-
00AW	-	-
0017	-	-
0018	-	-
00L9	-	-
0019	-	-
0020	-	-
0052	-	-
00CR	-	-
0009	-	-
0022	-	-
0023	-	-
0025	-	-
00CS	-	-
0026	-	-
0027	-	-
00FM	-	-
0035	-	-
0036	-	-
0038	-	-
0039	-	-
00AT	-	-
0028	-	-
0029	-	-
0030	-	-
0031	-	-

Cod.	cm	Euro
0001	20,8	2,50
0002	20,8	2,50
0003	23,0	5,30
00CC	24,5	11,02
00CA	-	-
00L3	-	-
0067	-	-
0004	17,9	2,50
0005	17,9	2,50
0006	20,0	5,30
00L6	-	-
00CD	21,3	10,92
00CB	-	-
0007	14,9	1,46
0008	11,0	1,46
0010	28,0	13,94
0011	25,3	5,82
0012	25,3	5,82
0013	16,5	7,60
0014	-	-
0015	-	-
0016	-	-
0059	-	-
00AW	-	-
0017	16,0	1,66
0018	-	-
00L9	-	-
0019	-	-
0020	22,7	7,28
0052	-	-
00CR	-	-
0009	-	-
0022	-	-
0023	-	-
0025	-	-
00CS	-	-
0026	-	-
0027	-	-
00FM	-	-
0035	-	-
0036	-	-
0038	-	-
0039	-	-
00AT	-	-
0028	17,9	2,50
0029	20,1	2,50
0030	-	-
0031	-	-

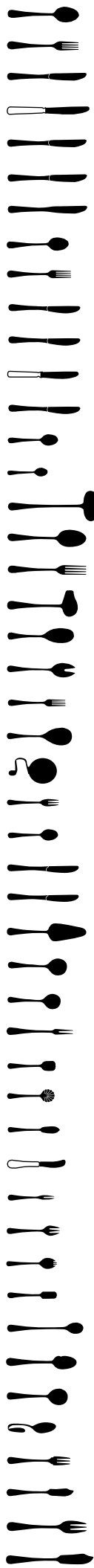

MAITRE 2010

PINTINOX

inox 18/10
mm 2,5



PAGAIA 2470

PINTINOX

inox 18/10

mm 2,5



Cod.	cm	Euro
0001	21,5	2,40
0002	21,5	2,40
0003	23,5	4,22
00CC	-	-
00CA	-	-
00L3	-	-
0067	-	-
0004	-	-
0005	18,5	2,30
0006	20,3	4,22
00L6	-	-
00CD	-	-
00CB	-	-
0007	15,0	1,46
0008	11,2	1,46
0010	29,0	13,42
0011	25,0	5,62
0012	25,0	5,62
0013	-	-
0014	-	-
0015	-	-
0016	-	-
0059	-	-
00AW	-	-
0017	17,2	1,66
0018	-	-
00L9	-	-
0019	-	-
0020	-	-
0052	-	-
00CR	-	-
0009	-	-
0022	-	-
0023	-	-
0025	-	-
00CS	-	-
0026	-	-
0027	-	-
00FM	-	-
0035	-	-
0036	-	-
0038	-	-
0039	-	-
00AT	-	-
0028	-	-
0029	-	-
0030	-	-
0031	-	-

Cod.	cm	Euro
0001	19,6	2,30
0002	19,4	2,30
0003	22,2	4,76
00CC	-	-
00CA	-	-
00L3	-	-
0067	-	-
0004	17,8	2,18
0005	17,4	2,18
0006	19,6	4,76
00L6	-	-
00CD	-	-
00CB	-	-
0007	13,4	1,36
0008	11,5	1,36
0010	26,2	13,42
0011	22,7	5,62
0012	23,2	5,62
0013	17,1	7,60
0014	-	-
0015	-	-
0016	-	-
0059	-	-
00AW	-	-
0017	14,4	1,66
0018	-	-
00L9	-	-
0019	-	-
0020	23,2	8,94
0052	-	-
00CR	-	-
0009	-	-
0022	-	-
0023	-	-
0025	-	-
00CS	-	-
0026	-	-
0027	-	-
00FM	-	-
0035	-	-
0036	-	-
0038	-	-
0039	-	-
00AT	-	-
0028	18,3	3,02
0029	19,7	3,02
0030	-	-
0031	-	-

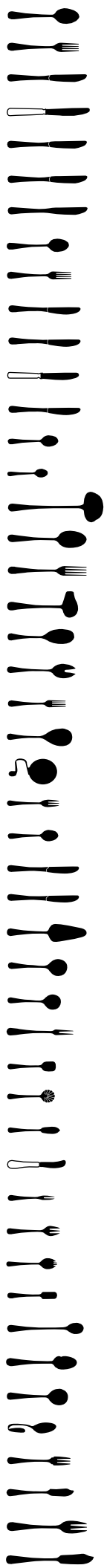

BRISTOL 2140

PINTINOX

inox 18/10
mm 2,5



AMERICA

2240

PINTINOX

inox 18/10

mm 2,5



Cod.	cm	Euro
0001	19,5	2,30
0002	19,5	2,30
0003	21,0	4,44
00CC	-	-
00CA	-	-
00L3	21,5	2,38
0067	-	-
0004	17,8	2,18
0005	17,1	2,18
0006	18,7	4,44
00L6	18,9	2,38
00CD	-	-
00CB	-	-
0007	13,3	1,26
0008	11,6	1,14
0010	28,0	13,42
0011	22,0	5,62
0012	22,3	5,62
0013	16,8	7,60
0014	-	-
0015	21,4	6,98
0016	-	-
0059	-	-
00AW	-	-
0017	15,9	1,56
0018	15,2	1,66
00L9	17,2	2,28
0019	-	-
0020	24,0	6,76
0052	-	-
00CR	-	-
0009	-	-
0022	13,1	1,36
0023	-	-
0025	-	-
00CS	-	-
0026	-	-
0027	-	-
00FM	-	-
0035	-	-
0036	22,0	2,08
0038	-	-
0039	-	-
00AT	-	-
0028	18,9	2,70
0029	22,2	2,70
0030	22,3	5,62
0031	24,5	5,62

Cod.	cm	Euro
0001	19,3	2,30
0002	19,4	2,30
0003	21,1	4,44
00CC	-	-
00CA	-	-
00L3	-	-
0067	-	-
0004	17,8	2,18
0005	16,6	2,18
0006	18,0	4,44
00L6	-	-
00CD	-	-
00CB	-	-
0007	13,2	1,26
0008	11,6	1,26
0010	27,2	13,42
0011	22,2	5,62
0012	22,1	5,62
0013	16,0	7,60
0014	-	-
0015	-	-
0016	-	-
0059	-	-
00AW	-	-
0017	15,5	1,66
0018	-	-
00L9	-	-
0019	-	-
0020	23,0	6,76
0052	-	-
00CR	-	-
0009	-	-
0022	-	-
0023	-	-
0025	-	-
00CS	-	-
0026	-	-
0027	-	-
00FM	-	-
0035	-	-
0036	-	-
0038	-	-
0039	17,2	2,18
00AT	12,4	3,54
0028	17,7	2,70
0029	18,6	2,70
0030	-	-
0031	-	-

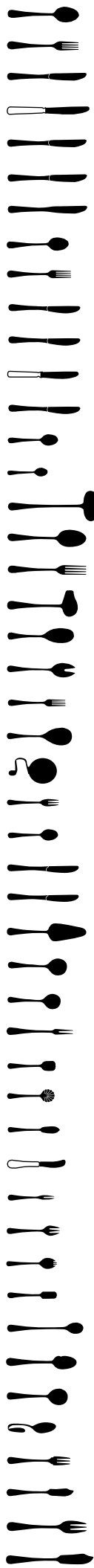

HOTEL 2020

PINTINOX

inox 18/10
mm 2,5



BRASILIA

2230

PINTINOX

inox 18/10

mm 2,5



Cod.	cm	Euro
0001	19,5	2,30
0002	19,5	2,30
0003	21,0	4,44
00CC	-	-
00CA	-	-
00L3	-	-
0067	-	-
0004	17,8	2,18
0005	17,1	2,18
0006	18,7	4,44
00L6	-	-
00CD	-	-
00CB	-	-
0007	13,3	1,26
0008	11,6	1,14
0010	28,0	13,42
0011	22,0	5,62
0012	22,3	5,62
0013	16,8	7,60
0014	-	-
0015	21,4	6,98
0016	-	-
0059	-	-
00AW	-	-
0017	15,9	1,56
0018	-	-
00L9	-	-
0019	-	-
0020	24,0	6,76
0052	-	-
00CR	-	-
0009	-	-
0022	13,1	1,36
0023	-	-
0025	-	-
00CS	-	-
0026	-	-
0027	-	-
00FM	-	-
0035	-	-
0036	22,0	2,08
0038	-	-
0039	-	-
00AT	-	-
0028	18,9	2,70
0029	22,2	2,70
0030	-	-
0031	-	-

Cod.	cm	Euro
0001	19,6	2,08
0002	19,6	2,08
0003	21,0	4,44
00CC	-	-
00CA	-	-
00L3	-	-
0067	-	-
0004	17,8	1,98
0005	17,9	1,98
0006	19,2	4,44
00L6	-	-
00CD	-	-
00CB	-	-
0007	13,7	1,46
0008	12,3	1,36
0010	27,5	13,42
0011	22,0	5,62
0012	22,4	5,62
0013	18,0	7,60
0014	-	-
0015	21,8	6,98
0016	-	-
0059	-	-
00AW	-	-
0017	15,9	1,46
0018	-	-
00L9	-	-
0019	-	-
0020	21,7	8,94
0052	-	-
00CR	-	-
0009	-	-
0022	13,6	1,26
0023	-	-
0025	-	-
00CS	-	-
0026	-	-
0027	-	-
00FM	-	-
0035	-	-
0036	22,0	1,98
0038	-	-
0039	-	-
00AT	-	-
0028	19,8	2,82
0029	22,3	2,82
0030	-	-
0031	-	-

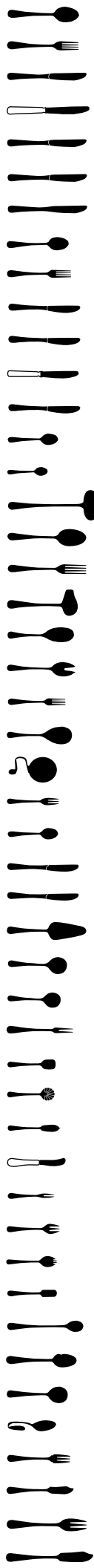

BETA 1710

PINTINOX

inox 18/10
mm 2,5



GAMMA 2150

PINTINOX

inox 18/10

mm 2,5



Cod.	cm	Euro
0001	19,6	2,08
0002	19,6	2,08
0003	21,0	4,44
00CC	-	-
00CA	-	-
00L3	21,6	2,38
0067	-	-
0004	17,8	1,98
0005	17,9	1,98
0006	19,1	4,44
00L6	19,5	2,38
00CD	-	-
00CB	-	-
0007	13,7	1,46
0008	12,3	1,36
0010	27,5	13,42
0011	22,0	5,62
0012	22,4	5,62
0013	18,0	7,60
0014	-	-
0015	21,8	6,98
0016	-	-
0059	-	-
00AW	-	-
0017	15,9	1,46
0018	-	-
00L9	-	-
0019	-	-
0020	21,7	8,94
0052	-	-
00CR	-	-
0009	-	-
0022	13,6	1,26
0023	-	-
0025	-	-
00CS	-	-
0026	-	-
0027	-	-
00FM	-	-
0035	-	-
0036	22,0	1,98
0038	-	-
0039	18,2	1,98
00AT	11,7	3,54
0028	19,8	2,82
0029	22,3	2,82
0030	-	-
0031	-	-

Cod.	cm	Euro
0001	19,7	2,18
0002	19,3	2,18
0003	21,2	4,76
00CC	-	-
00CA	-	-
00L3	-	-
0067	-	-
0004	18,6	2,08
0005	17,4	2,08
0006	19,9	4,76
00L6	-	-
00CD	-	-
00CB	-	-
0007	13,8	1,26
0008	11,8	1,26
0010	26,9	13,42
0011	21,9	5,82
0012	22,5	5,82
0013	17,6	7,60
0014	-	-
0015	-	-
0016	-	-
0059	-	-
00AW	-	-
0017	17,5	1,26
0018	-	-
00L9	-	-
0019	-	-
0020	21,6	8,84
0052	-	-
00CR	-	-
0009	-	-
0022	-	-
0023	-	-
0025	-	-
00CS	-	-
0026	-	-
0027	-	-
00FM	-	-
0035	-	-
0036	-	-
0038	-	-
0039	-	-
00AT	-	-
0028	19,1	2,82
0029	20,6	2,82
0030	-	-
0031	-	-

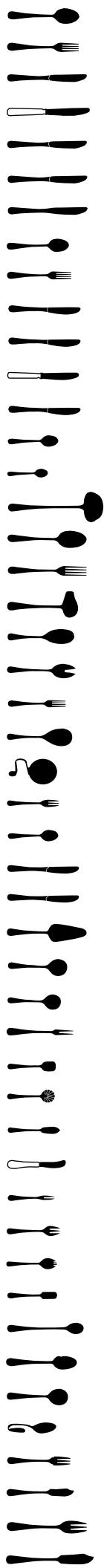

ISCHIA 2250

PINTINOX

inox 18/10
mm 2,5



TEMA

2120

PINTINOX

inox 18/10

mm 2,5



Cod.	cm	Euro
0001	19,6	1,98
0002	19,8	1,98
0003	21,2	4,76
00CC	-	-
00CA	-	-
00L3	21,4	2,38
0067	-	-
0004	17,0	1,98
0005	17,1	1,98
0006	19,1	4,76
00L6	19,5	2,38
00CD	-	-
00CB	-	-
0007	14,8	1,04
0008	11,2	1,04
0010	27,7	13,42
0011	22,3	5,20
0012	22,7	5,20
0013	17,6	7,60
0014	-	-
0015	-	-
0016	14,9	1,26
0059	-	-
00AW	-	-
0017	-	-
0018	-	-
00L9	-	-
0019	-	-
0020	23,6	7,80
0052	-	-
00CR	-	-
0009	-	-
0022	-	-
0023	-	-
0025	-	-
00CS	-	-
0026	-	-
0027	-	-
00FM	-	-
0035	-	-
0036	-	-
0038	-	-
0039	-	-
00AT	-	-
0028	17,4	1,98
0029	19,5	1,98
0030	-	-
0031	-	-

Cod.	cm	Euro
0001	21,0	1,98
0002	21,0	1,98
0003	22,6	2,92
00CC	-	-
00CA	-	-
00L3	-	-
0067	-	-
0004	-	-
0005	18,5	1,88
0006	20,3	2,82
00L6	-	-
00CD	-	-
00CB	-	-
0007	14,7	1,26
0008	11,0	1,04
0010	-	-
0011	-	-
0012	-	-
0013	-	-
0014	-	-
0015	-	-
0016	-	-
0059	-	-
00AW	-	-
0017	16,0	1,26
0018	-	-
00L9	-	-
0019	-	-
0020	-	-
0052	-	-
00CR	-	-
0009	-	-
0022	-	-
0023	-	-
0025	-	-
00CS	-	-
0026	-	-
0027	-	-
00FM	-	-
0035	-	-
0036	-	-
0038	-	-
0039	-	-
00AT	-	-
0028	-	-
0029	-	-
0030	-	-
0031	-	-

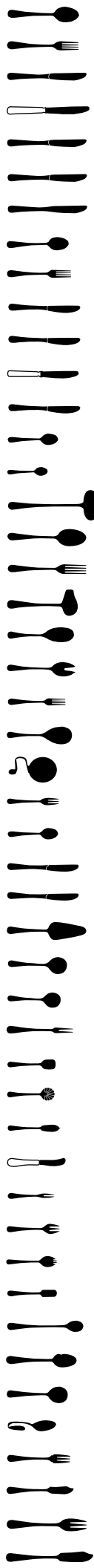

WAVE 2610

PINTINOX

inox 18/0
mm 3,0

NICKEL
FREE





Cod.	cm	Euro
0001	19,6	1,78
0002	19,6	1,78
0003	21,0	4,22
00CC	-	-
00CA	-	-
00L3	21,5	2,38
0067	-	-
0004	17,0	1,66
0005	16,9	1,66
0006	18,9	4,22
00L6	19,5	2,38
00CD	-	-
00CB	-	-
0007	13,4	1,04
0008	11,3	1,04
0010	27,2	12,58
0011	22,7	5,20
0012	22,6	5,20
0013	17,7	7,60
0014	-	-
0015	-	-
0016	-	-
0059	-	-
00AW	-	-
0017	13,5	1,26
0018	-	-
00L9	-	-
0019	-	-
0020	24,1	7,28
0052	-	-
00CR	-	-
0009	-	-
0022	-	-
0023	-	-
0025	-	-
00CS	-	-
0026	-	-
0027	-	-
00FM	-	-
0035	-	-
0036	-	-
0038	-	-
0039	-	-
00AT	-	-
0028	17,2	2,60
0029	19,6	2,60
0030	-	-
0031	-	-

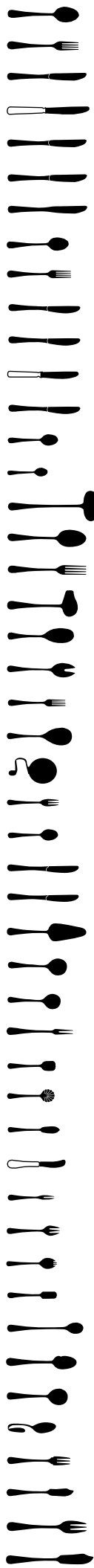

AIDA 1380

PINTINOX

inox 18/10
mm 2,0



AUSTRALIA 2

1400

PINTINOX

inox 18/10

mm 2,0



Cod.	cm	Euro
0001	19,0	1,78
0002	18,9	1,78
0003	20,4	4,22
00CC	-	-
00CA	-	-
00L3	19,5	2,38
0067	-	-
0004	-	-
0005	16,9	1,66
0006	18,4	4,22
00L6	19,5	2,38
00CD	-	-
00CB	-	-
0007	13,3	1,04
0008	10,8	1,04
0010	28,3	12,58
0011	21,6	4,90
0012	21,6	4,90
0013	-	-
0014	-	-
0015	-	-
0016	-	-
0059	-	-
00AW	-	-
0017	16,7	1,26
0018	-	-
00L9	-	-
0019	-	-
0020	23,0	7,70
0052	-	-
00CR	-	-
0009	-	-
0022	-	-
0023	-	-
0025	-	-
00CS	-	-
0026	-	-
0027	-	-
00FM	-	-
0035	-	-
0036	-	-
0038	-	-
0039	-	-
00AT	-	-
0028	-	-
0029	-	-
0030	-	-
0031	-	-

Cod.	cm	Euro
0001	21,1	1,78
0002	20,9	1,78
0003	23,0	4,22
00CC	-	-
00CA	-	-
00L3	-	-
0067	-	-
0004	-	-
0005	-	-
0006	-	-
00L6	-	-
00CD	-	-
00CB	-	-
0007	15,1	1,26
0008	11,0	1,14
0010	-	-
0011	-	-
0012	-	-
0013	-	-
0014	-	-
0015	-	-
0016	-	-
0059	-	-
00AW	-	-
0017	17,2	1,46
0018	-	-
00L9	-	-
0019	-	-
0020	-	-
0052	-	-
00CR	-	-
0009	-	-
0022	-	-
0023	-	-
0025	-	-
00CS	-	-
0026	-	-
0027	-	-
00FM	-	-
0035	-	-
0036	-	-
0038	-	-
0039	-	-
00AT	-	-
0028	-	-
0029	-	-
0030	-	-
0031	-	-

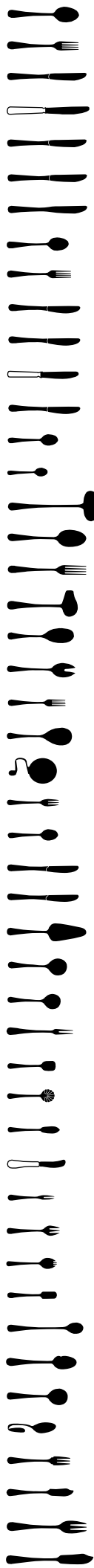

DOLPHIN

1360

PINTINOX

inox 18/10
mm 2,0



VALENCIA

0350

PINTINOX

inox 18/10

mm 2,0



Cod.	cm	Euro
0001	19,6	1,66
0002	19,6	1,66
0003	-	-
00CC	-	-
00CA	-	-
00L3	22,0	2,38
0067	-	-
0004	17,8	1,66
0005	17,7	1,66
0006	-	-
00L6	19,4	2,38
00CD	-	-
00CB	-	-
0007	14,1	0,94
0008	11,5	0,94
0010	26,9	11,76
0011	22,0	4,90
0012	21,9	4,90
0013	17,9	6,34
0014	-	-
0015	-	-
0016	-	-
0059	-	-
00AW	-	-
0017	15,1	1,04
0018	-	-
00L9	-	-
0019	-	-
0020	22,8	5,82
0052	-	-
00CR	-	-
0009	-	-
0022	-	-
0023	-	-
0025	-	-
00CS	-	-
0026	-	-
0027	-	-
00FM	-	-
0035	-	-
0036	-	-
0038	-	-
0039	-	-
00AT	-	-
0028	18,8	2,08
0029	19,6	2,08
0030	-	-
0031	-	-

Cod.	cm	Euro
0001	18,8	1,66
0002	18,6	1,66
0003	20,5	4,22
00CC	-	-
00CA	-	-
00L3	22,1	2,38
0067	-	-
0004	-	-
0005	16,5	1,66
0006	18,4	4,22
00L6	-	-
00CD	-	-
00CB	-	-
0007	13,4	1,04
0008	10,8	1,04
0010	27,3	12,58
0011	21,5	4,90
0012	21,4	4,90
0013	-	-
0014	-	-
0015	-	-
0016	-	-
0059	-	-
00AW	-	-
0017	13,7	1,14
0018	-	-
00L9	-	-
0019	-	-
0020	23,5	7,70
0052	-	-
00CR	-	-
0009	-	-
0022	-	-
0023	-	-
0025	-	-
00CS	-	-
0026	-	-
0027	-	-
00FM	-	-
0035	-	-
0036	-	-
0038	-	-
0039	-	-
00AT	-	-
0028	-	-
0029	-	-
0030	-	-
0031	-	-

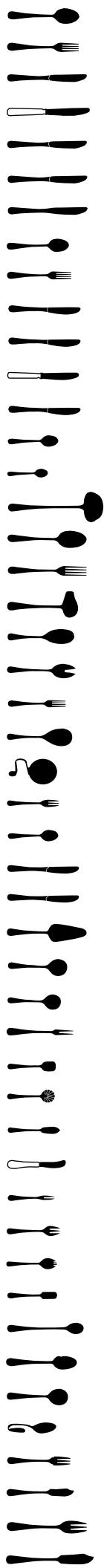

UNO
1410

PINTINOX

inox 18/10
mm 2,0





Cod.	cm	Euro
0001	19,6	1,66
0002	19,6	1,66
0003	22,2	3,78
00CC	-	-
00CA	-	-
00L3	22,0	2,38
0067	22,9	3,78
0004	17,8	1,66
0005	17,7	1,66
0006	19,5	3,68
00L6	19,4	2,38
00CD	-	-
00CB	-	-
0007	14,1	0,94
0008	11,5	0,94
0010	26,9	11,76
0011	22,0	4,90
0012	21,9	4,90
0013	17,9	6,34
0014	-	-
0015	-	-
0016	-	-
0059	-	-
00AW	-	-
0017	15,1	1,04
0018	-	-
00L9	-	-
0019	-	-
0020	22,8	5,82
0052	-	-
00CR	-	-
0009	-	-
0022	-	-
0023	-	-
0025	-	-
00CS	-	-
0026	-	-
0027	-	-
00FM	-	-
0035	-	-
0036	21,0	1,56
0038	-	-
0039	17,8	1,56
00AT	-	-
0028	18,0	2,08
0029	19,6	2,08
0030	-	-
0031	-	-

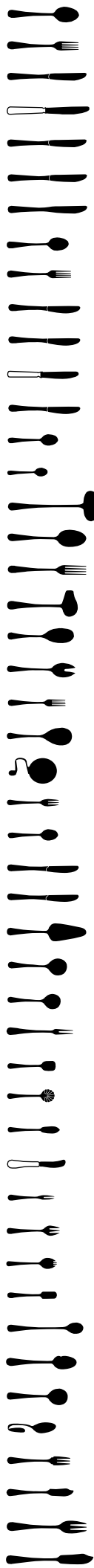

STRESA 0320

PINTINOX

inox 18/10
mm 2,0



03200051 Euro 2,60 cm 21,3 coltello pizza pizza knife

SUPERGA

0310

PINTINOX

inox 18/10

mm 2,0



Cod.	cm	Euro
0001	19,6	1,66
0002	19,6	1,66
0003	22,2	3,78
00CC	-	-
00CA	-	-
00L3	22,0	2,38
0067	-	-
0004	17,8	1,66
0005	17,7	1,66
0006	19,5	3,68
00L6	19,4	2,38
00CD	-	-
00CB	-	-
0007	14,1	0,94
0008	11,5	0,94
0010	26,9	11,76
0011	22,0	4,90
0012	21,9	4,90
0013	17,9	6,34
0014	-	-
0015	-	-
0016	-	-
0059	-	-
00AW	-	-
0017	15,1	1,04
0018	-	-
00L9	-	-
0019	-	-
0020	22,8	5,82
0052	-	-
00CR	-	-
0009	-	-
0022	-	-
0023	-	-
0025	-	-
00CS	-	-
0026	-	-
0027	-	-
00FM	-	-
0035	-	-
0036	-	-
0038	-	-
0039	-	-
00AT	-	-
0028	18,8	2,08
0029	19,6	2,08
0030	-	-
0031	-	-

Cod.	cm	Euro
0001	19,6	1,66
0002	19,6	1,66
0003	-	-
00CC	-	-
00CA	-	-
00L3	22,0	2,38
0067	-	-
0004	17,8	1,66
0005	17,7	1,66
0006	-	-
00L6	19,4	2,38
00CD	-	-
00CB	-	-
0007	14,1	0,94
0008	11,5	0,94
0010	26,9	11,76
0011	22,0	4,90
0012	21,9	4,90
0013	17,9	6,34
0014	-	-
0015	-	-
0016	-	-
0059	-	-
00AW	-	-
0017	15,1	1,04
0018	-	-
00L9	-	-
0019	-	-
0020	22,8	5,82
0052	-	-
00CR	-	-
0009	-	-
0022	-	-
0023	-	-
0025	-	-
00CS	-	-
0026	-	-
0027	-	-
00FM	-	-
0035	-	-
0036	-	-
0038	-	-
0039	-	-
00AT	-	-
0028	18,0	2,08
0029	19,6	2,08
0030	-	-
0031	-	-

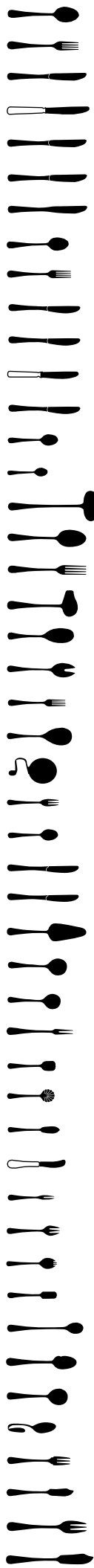

CAMBRIDGE 071M

PINTINOX

inox 18/10
mm 2,0





Cod.	cm	Euro
0001	19,7	1,36
0002	19,9	1,36
0003	-	-
00CC	-	-
00CA	-	-
00L3	21,6	2,38
0067	-	-
0004	17,1	1,36
0005	16,8	1,36
0006	-	-
00L6	19,5	2,38
00CD	-	-
00CB	-	-
0007	13,4	0,84
0008	11,4	0,84
0010	-	-
0011	-	-
0012	-	-
0013	-	-
0014	-	-
0015	-	-
0016	14,7	0,94
0059	-	-
00AW	-	-
0017	13,6	0,84
0018	-	-
00L9	-	-
0019	-	-
0020	-	-
0052	14,7	1,04
00CR	-	-
0009	-	-
0022	-	-
0023	-	-
0025	-	-
00CS	-	-
0026	-	-
0027	-	-
00FM	-	-
0035	-	-
0036	-	-
0038	-	-
0039	-	-
00AT	-	-
0028	-	-
0029	-	-
0030	-	-
0031	-	-

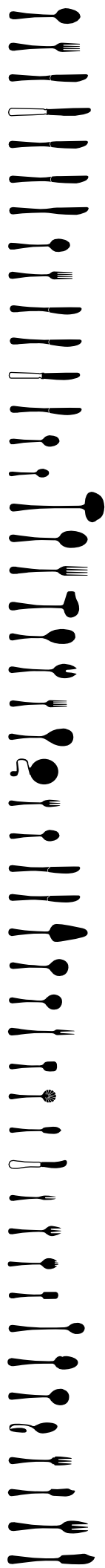

PUNTO 1220

PINTINOX

inox 18/0
mm 2,0

NICKEL
FREE



SNAKE

1140

PINTINOX

inox 18/10

mm 1,5

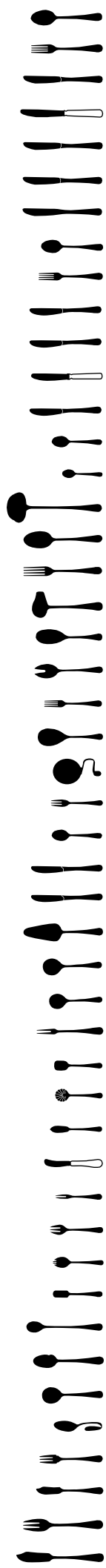

Cod.	cm	Euro
0001	20,8	1,26
0002	21,1	1,26
0003	23,0	2,82
00CC	-	-
00CA	-	-
00L3	22,5	1,30
0067	-	-
0004	-	-
0005	-	-
0006	-	-
00L6	-	-
00CD	-	-
00CB	-	-
0007	14,9	0,84
0008	11,1	0,74
0010	-	-
0011	-	-
0012	-	-
0013	-	-
0014	-	-
0015	-	-
0016	-	-
0059	-	-
00AW	-	-
0017	-	-
0018	-	-
00L9	-	-
0019	-	-
0020	-	-
0052	-	-
00CR	-	-
0009	-	-
0022	-	-
0023	-	-
0025	-	-
00CS	-	-
0026	-	-
0027	-	-
00FM	-	-
0035	-	-
0036	-	-
0038	-	-
0039	-	-
00AT	-	-
0028	-	-
0029	-	-
0030	-	-
0031	-	-

Cod.	cm	Euro
0001	19,6	1,26
0002	19,6	1,26
0003	-	-
00CC	-	-
00CA	-	-
00L3	22,0	2,38
0067	-	-
0004	17,8	1,26
0005	17,7	1,26
0006	-	-
00L6	19,4	2,38
00CD	-	-
00CB	-	-
0007	14,1	0,94
0008	11,5	0,84
0010	-	-
0011	-	-
0012	-	-
0013	-	-
0014	-	-
0015	-	-
0016	-	-
0059	-	-
00AW	-	-
0017	15,1	0,94
0018	-	-
00L9	-	-
0019	-	-
0020	-	-
0052	-	-
00CR	-	-
0009	-	-
0022	-	-
0023	-	-
0025	-	-
00CS	-	-
0026	-	-
0027	-	-
00FM	-	-
0035	-	-
0036	-	-
0038	-	-
0039	-	-
00AT	-	-
0028	18,0	1,66
0029	19,6	1,66
0030	-	-
0031	-	-

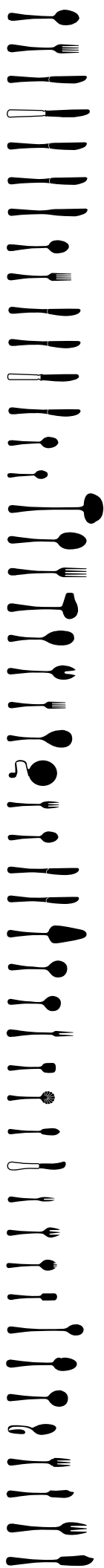

ECO BAGUETTE

0280

PINTINOX

inox 18/0

mm 2,0

NICKEL
FREE



TOURING

1250

PINTINOX

inox 18/0

mm 2,0

NICKEL
FREE



Cod.	cm	Euro
0001	21,0	1,14
0002	21,0	1,14
0003	22,0	2,82
00CC	-	-
00CA	-	-
00L3	22,0	2,60
0067	-	-
0004	-	-
0005	-	-
0006	-	-
00L6	-	-
00CD	-	-
00CB	-	-
0007	15,2	0,84
0008	11,1	0,84
0010	-	-
0011	-	-
0012	-	-
0013	-	-
0014	-	-
0015	-	-
0016	-	-
0059	-	-
00AW	-	-
0017	14,7	0,84
0018	-	-
00L9	-	-
0019	-	-
0020	-	-
0052	-	-
00CR	-	-
0009	-	-
0022	-	-
0023	-	-
0025	-	-
00CS	-	-
0026	-	-
0027	-	-
00FM	-	-
0035	-	-
0036	-	-
0038	-	-
0039	-	-
00AT	-	-
0028	-	-
0029	-	-
0030	-	-
0031	-	-

Cod.	cm	Euro
0001	20,0	0,94
0002	20,0	0,94
0003	22,0	2,82
00CC	-	-
00CA	-	-
00L3	-	-
0067	-	-
0004	-	-
0005	-	-
0006	-	-
00L6	-	-
00CD	-	-
00CB	-	-
0007	14,5	0,62
0008	11,0	0,62
0010	-	-
0011	-	-
0012	-	-
0013	-	-
0014	-	-
0015	-	-
0016	-	-
0059	-	-
00AW	-	-
0017	16,1	0,84
0018	-	-
00L9	-	-
0019	-	-
0020	-	-
0052	-	-
00CR	-	-
0009	-	-
0022	-	-
0023	-	-
0025	-	-
00CS	-	-
0026	-	-
0027	-	-
00FM	-	-
0035	-	-
0036	-	-
0038	-	-
0039	-	-
00AT	-	-
0028	-	-
0029	-	-
0030	-	-
0031	-	-

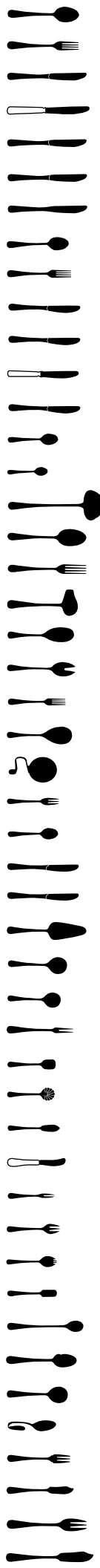

TUBE 1120

PINTINOX

inox 18/0
mm 1,5



98800860 Euro 16,70 set 100 anelli in plastica set 100 plastic rings





C O N F E Z I O N I

P a c k a g i n g











POSATE CON CRAVATTA

DISPONIBILE
SUBITO A
MAGAZZINO
AVAILABLE
IN STOCK
IMMEDIATELY

Cutlery packed with "cravatta"



Cod. 2240E... Cod. 1380E... Cod. 1250E...
America Aida Touring

	Descrizione	Description	Euro	Euro	Euro
 N° 1	001	Cucchiaino tavola Table spoon - Cuiller de table Tafellöffel - Cuchara mesa	2,40	1,88	1,26
 N° 1	002	Forchetta tavola Table fork - Fourchette de table Tafelgabel - Tenedor mesa	2,40	1,88	1,26
 N° 1	003	Coltello tavola Table knife - Couteau de table Tafelmesser - Cuchillo mesa	4,64	4,32	-
 N° 1	0L3	Coltello tavola stampato Stamped table knife - Couteau de table estampé Tafelmesser gestanzt - Cuchillo mesa estampado	2,60	2,60	2,70
 N° 1	005	Forchetta frutta Dessert fork - Fourchette dessert Dessertgabel - Tenedor postre	2,40	-	-
 N° 1	006	Coltello frutta Dessert knife - Couteau dessert Dessertmesser - Cuchillo postre	4,54	-	-
 N° 1	0L6	Coltello frutta stampato Stamped dessert knife - Couteau dessert estampé Dessertmesser gestanzt - Cuchillo postre estamp.	2,48	-	-
 N° 1	007	Cucchiaino caffè Tea/coffee spoon - Cuiller à café Kaffeelöffel - Cuchara café	1,36	1,26	1,04
 N° 1	008	Cucchiaino moka Moka spoon - Cuiller à moka Mokkalöffel - Cucharita moka	1,36	1,14	-
 N° 1	022	Paletta gelato Ice cream spoon - Cuiller à glace Eislöffel - Cuchara para helado	1,56	-	-
 N° 1	036	Cucchiaino bibita Soda spoon - Cuiller à cocktail Limolöffel - Cuchara refresco	2,30	-	-

Imballi per posate e coltelli: master da 48 "cravatte" - Packaging for cutlery - knives: outhter carton including 48 "cravatte" - Emballages pour couverts - couteaux: carton de 48 "cravatte" - Verpackungen für Messer: Kartonverpackung zu 48 "Cravatte" - Embalajes para Tenedores: embalaje de 48 "cravatte"
Imballi per caffè e moka: master da 60 "cravatte" - Packaging for moka coffee maker: outhter carton including 60 "cravatte" - Emballages pour café-moka: carton de 60 "cravatte" - Verpackung für Kaffee - Mokkalöffel : Kartonverpackung zu 60 "Cravatte" - Embalajes para café-moka: embalaje de 60 "cravatte"

POSATE CON CHIAVE

Cutlery packed with "chiave" pack





















Cod. 2260C...
Sirio



Cod. 2030C...
Synthesis

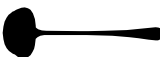



Cod.2010C...
Maitre

		Descrizione Description	Euro	Euro	Euro
	GR 3	301 Cucchiaino tavola - Table spoon - Cuiller de table - Tafellöffel - Cuchara mesa	8,22	8,22	7,70
	GR 3	302 Forchetta tavola - Table fork - Fourchette de table - Tafel gabel - Tenedor mesa	8,22	8,22	7,70
	GR 2	203 Coltello tavola - Table knife - Couteau de table - Tafelmesser - Cuchillo mesa	11,78	10,04	10,92
	GR 2	2L3 Colt. tav. stamp. - Stamp. table knife - Cout. de table estampé - Tafelmesser gest. - Cuch. mesa estam.	-	-	-
	GR 3	304 Cucchiaino frutta - Dessert spoon - Cuiller dessert - Dessertlöffel - Cuchara postre	-	-	-
	GR 3	305 Forchetta frutta - Dessert fork - Fourchette dessert - Dessertgabel - Tenedor postre	-	-	-
	GR 2	206 Coltello frutta - Dessert knife - Couteau dessert - Dessertmesser - Cuchillo postre	-	-	-
	GR 2	2L6 Colt. frutta stamp. - Stamp. dessert knife - Cout. dessert estampé - Dessertmes. gest. - Cuch. postre estam.	-	-	-
	GR 6	607 Cucchiaino caffè - Tea/coffee spoon - Cuiller à café - Kaffeelöffel - Cuchara café	9,98	9,68	9,06
	GR 6	608 Cucchiaino moka - Moka spoon - Cuiller à moka - Mokkalöffel - Cucharita moka	9,88	-	-
	GR 6	617 Forchettina dolce 3 spine - Pastry fork - Fourchette à gateau - Kuchengabel 3 Zinken - Tenedor postre 3 púas	-	-	-
	GR 3	322 Paletta gelato - Ice cream spoon - Cuiller à glace - Eislöffel - Cuchara para helado	-	-	-
	GR 3	336 Cucchiaino bibita - Soda spoon - Cuiller à cocktail - Limolöffel - Cuchara refresco	-	-	-
	GR 3	328 Forchetta pesce - Fish fork - Fourchette à poisson - Fischgabel - Tenedor pescado	-	-	-
	GR 3	329 Coltello pesce - Fish knife - Couteau à poisson - Fischmesser - Cuchillo pescado	-	-	-
	GR 1	010 Mestolo - Soup ladle - Louche - Suppenschöpfer - Cazo sopa	-	-	-
	GR 1	011 Cucchiaino servire - Serving spoon - Cuiller de service - Servierlöffel - Cuchara servir	-	-	-
	GR 1	012 Forchettone servire - Serving fork - Fourchette de service - Serviergabel - Tenedor servir	-	-	-
	GR 1	015 Forchettone insalata - Salad fork - Fourchette à salade - Salatgabel - Tenedor ensalada	-	-	-
	GR 1	020 Pala torta - Cake server - Pelle à tarte - Tortenheber - Pala paste	-	-	-

Imballi per posate e coltelli: pezzi servire: master da 24 chiavi - Packaging for cutlery - knives - serving items outer carton: including 24 "Chiave" - Emballages pour couverts - couteaux - service: carton de 24 "Chiave" - Verpackungen für Besteck - Serviermesser: Kartonverpackung zu 24 - "Chiave" - Embalajes para cubiertos - cuchillos - servir: embalaje de 24 "Chiave"

POSATE CON CHIAVE

						
Cod. 2240C...	Cod. 1710C...	Cod.1380C...	Cod.0320C...	Cod.1220C...	Cod.2170C...	Cod. 0750C...
America	Beta	Aida	Stresa	Punto	Solaris	Cateri
Euro	Euro	Euro	Euro	Euro	Euro	Descr. Euro
7,08	6,46	5,52	5,30	4,26	8,22	GR 2 251 Coltello pizza Pizza knife Couteau à pizza Pizzamesser Cuchillo pizza 6,84
7,08	6,46	5,52	5,30	4,26	8,22	
9,18	9,18	-	-	-	10,04	
4,94	-	5,26	4,94	4,94	-	
6,98	-	-	5,20	-	-	GR 2 267 Coltello bistecca Meat knife Couteau à viande Steakmesser Cuchillo chuletero 7,04
6,98	-	-	5,20	-	-	
9,18	-	-	-	-	-	
4,84	-	-	4,84	-	-	
7,50	8,84	6,46	6,14	5,52	9,98	GR 3 366 Forchetta pizza Pizza fork - Fourchette à pizza - Pizza Gabel - Tenedor pizza 5,30
7,50	8,74	-	5,94	5,42	-	
9,78	8,94	-	6,76	-	-	
4,48	4,16	-	-	-	-	
6,46	6,14	-	-	-	-	GR 3 357 Cucchiaio lungo Long spoon Cuilleur long Spaghettlöffel Cuchara larga 8,32
8,32	-	-	-	-	-	
8,32	-	-	-	-	-	
13,74	13,74	-	-	-	-	
5,94	5,94	-	-	-	-	GR 3 358 Forchetta lunga Long fork Fourchette longue Spaghettigabel Tenedor largo 8,32
5,94	5,94	-	-	-	-	
-	7,60	-	-	-	-	
7,08	9,16	-	-	-	-	











Imballo per mestoli: master da 12 chiavi- Packaging for ladles: outer carton including 12 "Chiave" - Emballage louches: carton de 12 "Chiave" - Verpackungen für Schöpflöffel: Kartonverpackung zu 12 "Chiave" - Embalajes para espumaderas: embalaje de 12 "Chiave"

POSATE CON SCATOLA 11+1

Cutlery packed with 11+1 box



Cod. 17007... Cod. 22607... Cod. 22407... Cod. 21507... Cod. 20307...
Savoy Sirio America Gamma Synthesis

	Descrizione	Description	Euro	Euro	Euro	Euro	Euro
 N° 12	C01	Cucchiaio tavola - Table spoon - Cuiller de table - Tafellöffel - Cuchara mesa	37,14	34,96	31,22	28,72	34,96
 N° 12	C02	Forchetta tavola - Table fork - Fourchette de table - Tafelgabel - Tenedor mesa	37,14	34,96	31,22	28,72	34,96
 N° 12	C03	Coltello tavola - Table knife - Couteau de table - Tafelhohlheftmesser - Cuchillo mesa	65,88	72,60	55,62	55,62	62,24
 N° 12	C04	Cucchiaio frutta - Dessert spoon - Cuiller dessert - Dessertlöffel - Cuchara postre	-	34,96	28,92	27,48	-
 N° 12	C05	Forchetta frutta - Dessert fork - Fourchette dessert - Dessertgabel - Tenedor postre	-	34,96	28,92	27,48	-
 N° 12	C06	Coltello frutta - Dessert knife - Couteau dessert - Dessertmesser - Cuchillo postre	-	72,60	55,40	55,40	-
 N° 12	C07	Cucchiaino caffè - Tea/coffee spoon - Cuiller à café - Kaffeelöffel - Cuchara café	23,92	23,74	18,74	21,24	22,48
 N° 12	C08	Cucchiaino moka - Moka spoon - Cuiller à moka - Mokkalöffel - Cucharita moka	-	22,48	15,92	19,14	-
 N° 12	C17	Forchettina dolce 3 spine - Pastry fork - Fourchette à gateau - Kuchengabel 3 Zinken - Tenedor postre 3 púas	-	25,28	22,48	21,24	-
 N° 12	C28	Forchetta pesce - Fish fork - Fourchette à poisson - Fischgabel - Tenedor pescado	-	40,36	-	-	-
 N° 12	C29	Coltello pesce - Fish knife - Couteau à poisson - Fischmesser - Cuchillo pescado	-	40,36	-	-	-











POSATE CON SCATOLA 11+1 TRASP.

DISPONIBILE
SUBITO A
MAGAZZINO
AVAILABLE
IN STOCK
IMMEDIATELY

Cutlery packed with transparent 11+1 box



Cod.0450K... Cod.1700K... Cod.2260K... Cod.2240K... Cod.2150K... Cod.2030K...
Concept Savoy Sirio America Gamma Synthesis

	Descrizione Description	Euro	Euro	Euro	Euro	Euro	Euro
 N° 12	C01 Cucchiaino tavola - Table spoon - Cuiller de table - Tafellöffel - Cuchara mesa	53,36	36,72	32,76	29,22	27,04	32,76
 N° 12	C02 Forchetta tavola - Table fork - Fourchette de table - Tafelgabel - Tenedor mesa	53,36	36,72	32,76	29,22	27,04	32,76
 N° 12	C03 Coltello tavola - Table knife - Couteau de table - Tafelhohlheftmesser - Cuchillo mesa	77,44	66,74	72,14	55,62	55,62	61,24
 N° 12	C04 Cucchiaino frutta - Dessert spoon - Cuiller dessert - Dessertlöffel - Cuchara postre	-	-	-	-	-	-
 N° 12	C05 Forchetta frutta - Dessert fork - Fourchette dessert - Dessertgabel - Tenedor postre	52,84	-	32,14	28,94	26,52	-
 N° 12	C06 Coltello frutta - Dessert knife - Couteau dessert - Dessertmesser - Cuchillo postre	75,72	-	71,72	55,40	55,40	-
 N° 12	C07 Cucchiaino caffè - Tea/coffee spoon - Cuiller à café - Kaffeelöffel - Cuchara café	34,22	22,36	21,74	16,74	19,46	19,66
 N° 12	C08 Cucchiaino moka - Moka spoon - Cuiller à moka - Mokkalöffel - Cucharita moka	34,00	-	21,42	15,92	19,14	-
 N° 12	C17 Forchettina dolce 3 spine - Pastry fork - Fourchette à gateau - Kuchengabel 3 Zinken - Tenedor postre 3 púas	39,00	-	24,34	21,22	19,66	-
 N° 12	C28 Forchetta pesce - Fish fork - Fourchette à poisson - Fischgabel - Tenedor pescado	-	-	-	-	-	-
 N° 12	C29 Coltello pesce - Fish knife - Couteau à poisson - Fischmesser - Cuchillo pescado	-	-	-	-	-	-

Imballo per posateria : Master da 10 scatole - Packaging for cutlery: outer carton including 10 boxes - Emballage pour couverts : carton de 10 boîtes - Verpackung für Besteck . Kartonverpackung zu 10 Schachteln - Embalaje para cubiertos: embalaje de 10 cajas

CONFEZIONAMENTO E LIBERO SERVIZIO

Packaging

CHIAVE

....C...

Aggiungere al prezzo dello sfuso

Add to the price of the unpacked item for each package

Ajouter au prix des pièces en vrac

Dem Preis des nicht verpackten Artikels für jede Packung hinzurechnen

Adicionar al precio del artículo no acondicionado

Euro 0,58

Quantità minima di 120 Chiavi per singolo articolo.
Tutte le posate possono essere confezionate con la Chiave.

The minimum quantity is 120 Chiave units per reference. All cutlery models can be packed with Chiave.



CRAVATTA

....E...

Aggiungere al prezzo dello sfuso

Add to the price of the unpacked item for each package

Ajouter au prix des pièces en vrac

Dem Preis des nicht verpackten Artikels für jede Packung hinzurechnen

Adicionar al precio del artículo no acondicionado

Euro 0,24

Quantità minima di 240 Cravatte per singolo articolo.
Tutte le posate possono essere confezionate con la Cravatta.

The minimum quantity is 240 Cravatta units per reference. All cutlery models can be packed with Cravatta.



CARTELLE PINTINOX

Pintinox coloured hang blister

Cod.	Colour	Euro
90530016	green	2,30
90530017	lillac	
90530018	fucsia	
90530019	blue	

Quantità minima di 24 cartelle per singolo articolo.
Tutte le posate possono essere confezionate con la cartella.

The minimum quantity is 24 hang blister units per reference. All cutlery models can be packed with hang blister.



CONFEZIONAMENTO E LIBERO SERVIZIO

BOX 5+1 CASH & CARRY

....V6...

Aggiungere al prezzo dello sfuso. Minimo ordine 240 pz

Add to the price of the unpacked item for each package. Minimum order quantity 240 pcs

Ajouter au prix des pièces en vrac

Dem Preis des nicht verpackten Artikels für jede Packung hinzurechnen

Adicionar al precio del artículo no acondicionado

Euro 1,96



SCATOLE 11+1

....7C..

Aggiungere al prezzo dello sfuso

Add to the price of the unpacked item for each package.

Ajouter au prix des pièces en vrac

Dem Preis des nicht Verpackten Artikels für jede Packung hinzurechnen

Adicionar al precio del artículo no acondic.

Euro 3,62

Quantita'minima 144 pezzi per singolo articolo. Tutte le posate possono essere confezionate in Scatole 11+1.

The minimum quantity 144 units per reference. All cutlery models can be packed in box 11+1.



BOX 11+1 TRASPARENTE

....KC..

Aggiungere al prezzo dello sfuso

Add to the price of the unpacked item for each package.

Ajouter au prix des pièces en vrac

Dem Preis des nicht Verpackten Artikels für jede Packung hinzurechnen

Adicionar al precio del artículo no acondicionado

Euro 3,62



Quantita'minima 240 pezzi per singolo articolo. Tutte le posate possono essere confezionate in Scatole 11+1 Trasparenti.

The minimum quantity 240 units per reference. All cutlery models can be packed in transparent box 11+1.

CONFEZIONAMENTO E LIBERO SERVIZIO

VALVE
Euro 1,30



ETICHETTA BAR CODE SINGOLA

....3...

Aggiungere al prezzo dello sfuso

Add to the price of the unpacked item for each package.

Ajouter au prix des pièces en vrac

Dem Preis des nicht Verpackten Artikels für jede Packung hinzurechnen

Adicionar al precio del articulo no acondicionado

Euro 0,06



Quantita'minima 1200 pezzi.

The minimum quantity 1200 units.

Imballi per posate - coltelli: master da 48 "bar code label" - Packaging for cutlery- knives: outhter carton including 48 "bar code label" - Emballages pour couverts - couteaux: carton de 48 "bar code label" - Verpackungen für Messer: Kartonverpackung zu 48 "bar code label" - Embalajes para Tenedores: embalaje de 48 "bar code label"

Imballi x caffè - moka: master da 60 "bar code label" - Packaging for moka coffee maker: outhter carton including 60 "bar code label" - Emballages pour café-moka: carton de 60 "bar code label" - Verpackung für Kaffee - Mokkalöffel : Kartonverpackung zu 60 "bar code label" - Embalajes para café-moka: embalaje de 60 "bar code label"





G L I S P E C I A L I

Special cutlery



Per alimenti
Suitable for foodstuffs
Apte au contact avec les aliments
Für Lebensmittel
Apto para alimentos



Garantito per lavastoviglie
Dishwasher safe
Inalterable dans lave-vaisselle
Spuelmaschinenfest
Apto para lavavajillas

TAVOLA - Table

CUCCHIAIO TAVOLA 18/10

Table spoon 18/10 - Cuiller de table 18/10

Tafellöffel 18/10 - Cuchara de mesa 18/10

Cod. 07400001

cm	Euro
20	3,92



FORCHETTA TAVOLA 18/10

Table fork 18/10 - Fourchette de table 18/10

Gabel mit 18/10 - Tenedor de mesa 18/10

Cod. 07400002

cm	Euro
19,5	3,92



COLTELLO BISTECCA

Steak knife - Couteau steak

Steakmesser - Cuchillo chuletero

Cod. 07400067

cm	Euro
21,1	5,62



CUCCHIAINO CAFFÈ 18/10

Tea-coffee spoon 18/10 - Cuiller a cafe 18/10

Kaffeelöffel 18/10 - Cuchara café 18/10

Cod. 07400007

cm	Euro
14,6	2,24



PASTA - Pasta

PALA LASAGNE 18/10

Lasagne server 18/10 - Pelle a lasagnes 18/10

Lasagneheber 18/10 - Paleta lasañas 18/10

Cod. 074000AE

cm	Euro
28	20,36



SERVISPAGHETTI 18/10

Spaghetti server 18/10 - Cuiller spaghetti 18/10

Spaghettischöpfer 18/10 - Cuchara de servir para espaguetis 18/10

Cod. 074000AS

cm	Euro
29,5	23,74



ARROSTO - *Roast meat*

FORCHETTONE ARROSTO 18/10

Carving fork 18/10 - Fourchette a roti 18/10

Vorlegemesser tenedor 18/10 - Trinchante asado 18/10

Cod. 07400068

cm	Euro
25,7	17,18



COLTELLONE ARROSTO cm 28

Carving knife - Couteau a roti

Vorlegemesser - Cuchillo grande asado

Cod. 07400069

cm	Euro
28	16,12



TRINCIAPOLLO

Poultry shears - Coupe-volailles

Geflügelschere - Tijeras para aves

Cod. 074000AN

cm	Euro
25	42,62



PESCE - *Fish*

SCAVINO PER ARAGOSTA 18/10

Lobster pick 18/10 - Curette a homard 18/10

Langustengabel 18/10 - Utensilio para langosta 18/10

Cod. 074000AF

cm	Euro
18,8	6,26



PINZA PER ARAGOSTA 18/10

Lobster/seafood cracker - Pince a crustaces

Langustenzange - Pinza para langosta

Cod. 074000AG

cm	Euro
18,8	32,34

**FORMAGGIO** - *Cheese*

COLTELLO FORMAGGIO 2 PUNTE

Cheese knife - Couteau a fromage

Käsemesser 2 zinken - Cuchillo queso 2 puntas

Cod. 074000AA

cm	Euro
21,8	6,68



COLTELLO GRANA

Parmesan pick - Couteau a parmesan

Parmesankäsemesser - Cuchillo queso duro

Cod. 074000AB

cm	Euro
18,2	7,74



COLTELLO FORMAGGIO DURO
Parmesan knife - Couteau fromage
Käsemesser - Cuchillo queso
Cod. 074000AD

cm	Euro
25,9	11,14



COLTELLO FORMAGGIO TENERO
Soft cheese knife - Couteau fromage pate molle
Messer für Weichkäse - Cuchillo queso blando
Cod. 074000AL

cm	Euro
21,5	6,68



PIZZA - Pizza

COLTELLO PIZZA/CROSTACEI
Pizza / seafood knife - Couteau a pizza/crustaces
Pizza/krustentiere messer - Cuchillo pizza/marisco
Cod. 07400051

cm	Euro
21	5,72



COLTELLO TAGLIO PIZZA
Pizza serving knife - Couteau a pizza
Serviermesser für pizza - Cuchillo corte pizza
Cod. 074000AD

cm	Euro
25,9	11,14



PALA SERVIRE PIZZA 18/10
Pizza server 18/10 - Pelle de service pour pizza 18/10
Pizzaschieber 18/10 - Paleta servir pizza 18/10
Cod. 074000AI

cm	Euro
21,5	20,78



TAVERNA - Party

SCHIACCIANOCI

Nutcraker - Casse-noix

Nussknacker - Cascanueces

Cod. 074000AH

cm	Euro
18,7	29,04



COLTELLO AGRUMI

Lemon/bar knife - Couteau agrumes

Südfruchtmesser - Cuchillo citricos

Cod. 074000AM

cm	Euro
23	6,78



CAVATAPPI A CAMPANA

Cork screw - Tirebouchon

Korkenzieher - Sacacorchos a campana

Cod. 074000AR

cm	Euro
15,5	49,94



DOLCE E PANE - *Cake and Bread*

PALA DOLCE 18/10

Cake server 18/10 - Pelle a tarte 18/10

Tortenheber 18/10 - Paleta postre 18/10

Cod. 074000AP

cm	Euro
27,8	20,36



COLTELLO PANE

Bread knife - Couteau a pain

Brotmesser - Cuchillo pan

Cod. 074000AC

cm	Euro
31,8	14,10



Ogni pezzo è confezionato singolarmente.

Packaging in individual gift bag.

En sachet cadeau individuel.

In Geschenkbeutel.

Cada articulo esta presentado en bolsa de regalo.





COLTELLO MANICO VUOTO

Table knife H.H.

00CC coltello tavola m.v. lama forgiata *table knife H.H and forged blade*00CD coltello frutta m.v. lama forgiata *dessert knife H.H and forged blade*

Cod.	Euro	
163000CC	11,02	Spaten
163000CD	10,92	



Cod.	Euro	
164000CC	11,02	Vittoriale
164000CD	10,92	



Cod.	Euro	
083000CC	11,02	Baguette
083000CD	10,92	



Cod.	Euro	
080000CC	11,02	Byron
080000CD	10,92	



Cod.	Euro	
059000CC	11,02	Palladium
059000CD	10,92	



Cod.	Euro	
081000CC	11,02	Pitagora
081000CD	10,92	



Cod.	Euro	
050000CC	11,02	Leonardo
050000CD	10,92	



Cod.	Euro	
227000CC	11,02	<i>Millenium</i>
227000CD	10,92	



Cod.	Euro	
228000CC	11,02	<i>Ritz</i>
228000CD	10,92	



Cod.	Euro	
206000CC	11,02	<i>Bernini</i>
206000CD	10,92	



Cod.	Euro	
205000CC	11,02	<i>Settecento</i>
205000CD	10,92	



Cod.	Euro	
226000CC	11,02	<i>Sirio</i>
226000CD	10,92	



Cod.	Euro	
220000CC	11,02	<i>Roma</i>
220000CD	10,92	



Cod.	Euro	
054000CC	11,02	<i>Filet</i>
054000CD	10,92	



Cod.	Euro	
201000CC	11,02	<i>Maitre</i>
201000CD	10,92	



Cod.	Euro	
170000CC	11,02	<i>Savoy</i>
170000CD	10,92	



COLTELLO BISTECCA

Steak knife

0067 coltello bistecca *steak knife*

Cod.	cm	Euro	
07600067	23	6,16	Professionale



Cod.	cm	Euro	
08000067	23	6,26	Byron



Cod.	cm	Euro	
08300067	23	6,26	Baguette



Cod.	cm	Euro	
22800067	22,8	6,26	Ritz



Cod.	cm	Euro	
22700067	23,6	6,26	Millenium



Cod.	cm	Euro	
20900067	22,5	5,30	Sabrina



COLTELLI BISTECCA

**INOX
FORGED**

Cod.	cm	Euro	
16900067	22	5,30	<i>Palace</i>

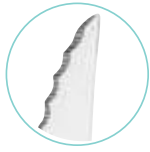

Cod.	cm	Euro	
05000067	23	6,26	<i>Leonardo</i>



Cod.	cm	Euro	
20300067	22,5	4,22	<i>Synthesis</i>

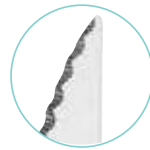

Cod.	cm	Euro	
03200067	22,9	3,78	<i>Stresa</i>



Cod.	cm	Euro	
076000EU	22,3	6,48	<i>Profess. c/manico in plastica</i>



SERIE CATERÌ

Cod.	cm	Euro	
07500067	23	3,46	<i>bistecca Cateri</i>

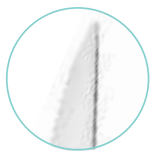

Cod.	cm	Euro	
07500051	21	3,22	<i>pizza Cateri</i>



FORCHETTA LUNGA 18/10
 Long fork 18/10 - Fourchette longue 18/10
 Spaghettigabel 18/10 - Tenedor largo 18/10
 Cod. 07500058

cm	Euro
22	2,70



FORCHETTA PIZZA CATERÌ 18/10
 Pizza fork 18/10 - Fourchette à pizza 18/10
 Pizza Gabel 18/10 - Tenedor pizza 18/10
 Cod. 07500066

cm	Euro
19,51	1,66



CUCCHIAIO LUNGO 18/10
 Long spoon 18/10 - Cuiller long 18/10
 Spaghettlöffel 18/10 - Cuchara larga 18/10
 Cod. 07500057

cm	Euro
22	2,70



Professional cutlery

Cod.	cm	Euro	
03200051	21,3	2,60	<i>pizza Stresa</i>



SCAVINO CROSTACEI

Lobster pick - Fourchette pour crustacés

Krustentiereregabel - Utensilio para crustáceos

Cod. 076000AF

cm	Euro
18,5	3,60



PINZA ARAGOSTA PROFESSIONAL CON MOLLA

Lobster cracker - Pince pour crustacés

Langustenzange - Pinza para langosta

Cod. 741000AG

cm	Euro
18,7	22,38



MULTIUSO CROSTACEI I PROFESSIONALI

Sea food pick - Fourchette pour crustacés

Krustentiereregabe - Utensilio para crustáceos

Cod. 076000MU

cm	Euro
23	3,56



COLTELLI PROFESSIONAL

Professional knives

MANARETTA

Cleaver - Couperet

Kochmesser - Cuchillo de carnicero

Cod. 741000EG

lama cm	(Euro pcs)	master	Euro master
18	19,62	4	78,48



COLTELLO MACELLAIO LAMA GRANDE

Butcher's knife - Boucher

Fleischmesser - Cuchillo carnicero

Cod.	lama cm	(Euro pcs)	master	Euro master
741000E6	20	17,60	6	105,60
741000E7	25	21,32	6	127,92



COLTELLO CUCINA

Chef knife - Couteau de cuisine

Küchenmesser - Cuchillo de cocina

Cod.	lama cm	(Euro pcs)	master	Euro master
741000EH	20	16,00	6	96,00
741000E1	25	18,66	6	111,96



COLTELLO CUCINA ORIENTALE

Japanese cook - Couteau de cuisine

Küchenmesser - Cuchillo de cocina

Cod. 741000EI

lama cm	(Euro pcs)	master	Euro master
18	16,00	6	96,00



COLTELLO CUCINA

Chef knife - Couteau de cuisine
Küchenmesser - Cuchillo de cocina
Cod. 741000EL

lama cm	(Euro pcs)	master	Euro master
15	14,96	6	89,76



COLTELLO PANE

Bread knife - Couteau à pain
Brotmesser - Cuchillo de pan

Cod.	lama cm	(Euro pcs)	master	Euro master
741000EM	20	13,36	6	80,16
741000E5	28	18,66	6	111,96



COLTELLO AFFETTATI

Slicer knife - Couteau à charcuterie
Ausschnittmesser - Cuchillo para fiambre
Cod. 741000EN

lama cm	(Euro pcs)	master	Euro master
20	13,36	6	80,16



COLTELLO DISOSSATORE

Boning knife - Couteau désosseur
Ausbeinmesser - Cuchillo deshuesador
Cod. 741000EO

lama cm	(Euro pcs)	master	Euro master
15	13,36	6	80,16



COLTELLO PER FILETTARE

Fillet knife - Couteau à fileter
Filetiermesser - Cuchillo rebanador
Cod. 741000EP

lama cm	(Euro pcs)	master	Euro master
20	13,36	6	80,16



COLTELLO PROSCIUTTO

Ham-Slicer - Couteau à jambon
Schinkenmesser - Cuchillo jamón

Cod.	lama cm	(Euro pcs)	master	Euro master
741000EQ	26	14,32	6	85,92
741000E4	33	17,08	6	102,48



COLTELLO SALMONE

Salmon knife - Couteau à saumon
Lachsmesser - Cuchillo para salmón
Cod. 741000ER

lama cm	(Euro pcs)	master	Euro master
26	15,48	6	92,88



FORCHETTONE ARROSTO

Carving fork - Fourchette à rôti
Bratengabel - Tenedor para asado
Cod. 741000ES

lama cm	(Euro pcs)	master	Euro master
18	12,84	6	77,04



COLTELLO CUCINA

Chef knife - Couteau de cuisine
Küchenmesser - Cuchillo de cocina
Cod. 741000ET

lama cm	(Euro pcs)	master	Euro master
12	9,02	6	54,12





COLTELLO BISTECCA CON SEGA

Full serration steak knife - Couteau à viande avec scie

Steakmesser mit Sägeschliff - Cuchillo de carne con dientes

Cod. 741000EU

lama cm	(Euro pcs)	master	Euro master
12	9,02	6	54,12



COLTELLO BISTECCA SENZA SEGA

Fine edged steak knife - Couteau à viande sans scie

Steakmesser ohne Sägeschliff - Cuchillo de carne sin dientes

Cod. 741000EY

lama cm	(Euro pcs)	master	Euro master
12	9,02	6	54,12



COLTELLO SPELUCCHINO

Paring knife - Couteau éplucheur

Spickmesser - Cuchillo pelador

Cod.	lama cm	(Euro pcs)	master	Euro master
741000EV	9	8,80	6	52,80
741000E2	10	9,02	6	54,12



COLTELLO VERDURA

Peeling knife - Couteau à légumes

Gemüsemesser - Cuchillo para verdura

Cod. 741000EZ

lama cm	(Euro pcs)	master	Euro master
7,5	8,80	6	52,80



MEZZALUNA

Mincing knife - Berceuse

Gemüsemesser - Media luna

Cod. 741000EB

lama cm	(Euro pcs)	master	Euro master
26	25,02	4	100,08



PUNTA GRANA

Parmesan cheese knife - Couteau à Parmesan

Parmesankäsemesser - Cuchillo queso duro

Cod. 741000EX

lama cm	(Euro pcs)	master	Euro master
12	12,84	6	77,04



APPENDINO MAGNETICO

Aluminium magnet hanger - Crochet magnétique

Magnethalter - Colgador magnético

Cod. 741000ED

lama cm	(Euro pcs)	master	Euro master
45	17,08	6	102,48



ACCIAINO

Sharpener - Fusil aiguiseur

Messerschaerfer - Afilador

Cod. 741000E3

lama cm	(Euro pcs)	master	Euro master
24,5	16,54	6	99,24



Ogni pezzo è confezionato singolarmente.

*Packaging in individual gift bag.**En sachet cadeau individuel.**In Geschenkbeutel.**Cada articulo esta presentado en bolsa de regalo.*

COLTELLI GRAND CHEF

Grand Chef knives

COLTELLO VERDURA

Peeling knife - Couteau à légumes

Gemüsemesser - Cuchillo para verdura

Cod. 745000EZ

lama cm	Euro
7,5	7,10



COLTELLO SPELUCCHINO

Paring knife - Couteau éplucheur

Spickmesser - Cuchillo pelador

Cod. 745000EV

lama cm	Euro
9	7,10



COLTELLO CUCINA

Chef knife - Couteau de cuisine

Küchenmesser - Cuchillo de cocina

Cod. 745000ET

lama cm	Euro
12	7,32



COLTELLO CUCINA

Chef knife - Couteau de cuisine
 Küchenmesser - Cuchillo de cocina
 Cod. 745000EH

lama cm	Euro
20	14,58



COLTELLO AFFETTATI

Slicer knife - Couteau à charcuterie
 Ausschnittmesser - Cuchillo para fiambre
 Cod. 745000EN

lama cm	Euro
20	10,42



COLTELLO PANE

Bread knife - Couteau à pain
 Brotmesser - Cuchillo de pan
 Cod. 745000EM

lama cm	Euro
20	10,42



Ogni pezzo è confezionato singolarmente.
Packaging in individual gift bag.
En sachet cadeau individuel.
In Geschenkbeutel.
 Cada artículo esta presentado en bolsa de regalo.



FORCHETTA 5 PUNTE

5 prong fork - Fourchette à 5 dents
Serviergabel 5 zinken - Tenedor 5 púas
Cod. 07600143

cm	(Euro pcs)	master	Euro master
30	8,60	12	103,20



CUCCHIAIONE RISOTTO

Rice spoon - Cuiller à "risotto"
Reislöffel - Cuchara de arroz
Cod. 07600280

cm	(Euro pcs)	master	Euro master
28	9,34	12	112,08



CUCCHIAIONE RISOTTO FORATO

Perforated rice spoon - Cuiller perforé à "risotto"
Reislöffel gelocht - Cuchara de arroz con agujeros
Cod. 07600260

cm	(Euro pcs)	master	Euro master
26	7,46	12	89,52



COLTELLO SERVIRE

Serving knife - Couteau à servir
Serviermesser - Cuchillo servir
Cod. 07600069

cm	(Euro pcs)	master	Euro master
32	11,56	12	138,72



CUCCHIAIONE SERVIRE

Serving spoon - Cuiller à servir

Servierlöffel - Cuchara servir

Cod. 07600060

cm	(Euro pcs)	master	Euro master
26	7,46	12	89,52



PALA LASAGNE

Spatula lasagna - Pelle à lasagnes

Lasagneheber - Pala lasaña

Cod. 07600080

cm	(Euro pcs)	master	Euro master
28	9,44	12	113,28



PALA TORTA

Cake server - Pelle à torte

Tortenheber - Pala pastel

Cod. 07600081

cm	(Euro pcs)	master	Euro master
30	11,24	12	134,88



PALA UOVO

Egg lifter - Pelle à oeuf

Eierheber - Pala huevos

Cod. 07600082

cm	(Euro pcs)	master	Euro master
28	12,52	12	150,24



CUCCHIAIONE PIZZAIOLO
Tomato spoon - Cuiller à tomates
Pizza Löffel - Cuchara para pizza
Cod. 07600014

cm	(Euro pcs)	master	Euro master
28	7,84	12	94,08



FORCHETTONE 3 PUNTE MULTIUSO
3 prong fork - Fourchette à 3 dents
Mehrzweckgabel mit 3 Zinken - Tenedor 3 púas multiuso
Cod. 07600288

cm	(Euro pcs)	master	Euro master
30	8,38	12	100,56



FORCHETTONE INSALATA
Salad fork - Fourchette à salade
Salatgabel - Tenedor ensalada
Cod. 07600015

cm	(Euro pcs)	master	Euro master
28	9,34	12	112,08



FORCHETTONE SERVIRE PER VASSOIO
Serving fork - Fourchette à servir
Serviergabel - Tenedor servir
Cod. 07600088

cm	(Euro pcs)	master	Euro master
24	6,48	12	77,76



ASTRA

**INOX
18/10**

S O L O
V E N D I T A
M A S T E R
O N L Y
M A S T E R
S E L L I N G

CUCCHIAIONE MULTIUSO

Serving spoon - Cuiller à servir

Servierlöffel - Cuchara servir multiuso

Cod. 07600059

cm	(Euro pcs)	master	Euro master
30	9,34	12	112,08



CUCCHIAIONE MULTIUSO FORATO

Perforated spoon - Cuiller perforé

Servierlöffel mit Lochern - Cuchara servir con agujeros

Cod. 07600259

cm	(Euro pcs)	master	Euro master
30	9,96	12	119,52



FORCHETTA PER VASSOIO

Serving fork - Fourchette à servir

Serviergabel - Tenedor servir

Cod. 07600033

cm	(Euro pcs)	master	Euro master
20	4,88	12	58,56



CUCCHIAIO

Serving spoon - Cuiller à servir

Servierlöffel - Cuchara servir

Cod. 07600040

cm	(Euro pcs)	master	Euro master
20	4,88	12	58,56



CUCCHIAIONE SERVIRE

Serving spoon - Cuiller à servir

Servierlöffel - Cuchara servir

Cod. 07600087

cm	(Euro pcs)	master	Euro master
24	6,48	12	77,76



FORCHETTONE INSALATA

Salad fork - Fourchette à salade

Salatgabel - Tenedor ensalada

Cod. 076000CF

cm	(Euro pcs)	master	Euro master
24	7,96	12	95,52



CUCCHIAIONE MULTIUSO FORATO

Perforated spoon - Cuiller perforé

Servierlöffel mit Lochern - Cuchara servir con agujeros

Cod. 07600287

cm	(Euro pcs)	master	Euro master
24	7,32	12	87,84



CUCCHIAIO MARMELLATA/MIELE

Jam/honey spoon - Cuiller confiture/miel

Marmelade/Honig Löffel - Cuchara marmelada/miel

Cod. 076000CN

cm	(Euro pcs)	master	Euro master
19	2,48	12	29,76



ASTRA

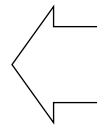

PITAGORA

Posate antiscivolo - Non slip cutlery

FORCHETTA SERVIRE PER VASSOIO

Serving fork - Fourchette à servir

Serviergabel - Tenedor servir

Cod. 08100033

cm	(Euro pcs)	master	Euro master
20	5,62	12	67,44



CUCCHIAIO SERVIRE

Serving spoon - Cuiller à servir

Servierlöffel - Cuchara servir

Cod. 08100040

cm	(Euro pcs)	master	Euro master
20	5,62	12	67,44



FORCHETTONE SERVIRE PER VASSOIO

Serving fork - Fourchette à servir

Serviergabel - Tenedor servir

Cod. 08100088

cm	(Euro pcs)	master	Euro master
24	7,28	12	87,36



CUCCHIAIONE SERVIRE

Serving spoon - Cuiller à servir

Servierlöffel - Cuchara servir

Cod. 08100087

cm	(Euro pcs)	master	Euro master
24	7,28	12	87,36



CUCCHIAIONE MULTIUSO

Multipurpose spoon - Cuiller multi-usage

Mehrzweckservierlöffel - Cuchara multiuso

Cod. 08100159

cm	(Euro pcs)	master	Euro master
30	9,36	12	112,32







A C C E S S O R I T A V O L A

T a b l e a c c e s s o r i e s



Per alimenti
Suitable for foodstuffs
Apte au contact avec les aliments
Für Lebensmittel
Apto para alimentos



Garantito per lavastoviglie
Dishwasher safe
Inalterable dans lave-vaisselle
Spuelmaschinenfest
Apto para lavavajillas

SOTTOPIATTI-CLOCHE

Underplate

INOX
18/10

SOLO
VENDITA
MASTER
ONLY
MASTER
SELLING

SOTTOPIATTO PROGETTO 1929

Underplate - Sous-assiette

Platzteller - Bajo plato

Cod. 50932831

Ø cm	Ø cm IN	Euro
31	17,8	36,58



SOTTOPIATTO BERNINI

Underplate - Sous-assiette

Platzteller - Bajo plato

Cod. 50932531

Ø cm	master	Euro
31	20	27,82



SOTTOBOTTIGLIA BERNINI

Bottle coaster - Dessous de bouteille

Flaschenteller - Posa botellas

Cod. 50913714

Ø cm	master	Euro
14	6	12,46



SOTTOBICCHIERE BERNINI

Coaster - Dessous de verre

Gläsernteller - Posa vasos

Cod. 50913611

Ø cm	master	Euro
11	6	8,76



SOTTOPIATTI

SOTTOPIATTO PITAGORA 1929

Underplate - Sous-assiette

Platzteller - Bajo plato

Cod. 57122231

Ø cm	Ø cm IN	Euro
31	20,4	31,78



PIATTINO PORTAPANE PITAGORA 1929

Bread Coaster - Plat à pain

Brotteller - Plato de pan

Cod. 57121714

Ø cm	Euro
14	7,92



CLOCHE SEMISFERICA CON POMOLO

Semispheric cloche with knob - Cloche hémispherique avec pommeau

Speiseglocke kugelförmig mit Griff - Cloche semiesferica con pomo

Cod. 509322..

Ø cm IN	h cm	for round tray Ø cm	Euro
22	12	30	30,18
24	13	30	32,04
26	14	35	37,80
28	15	35	44,82





ACCESSORI STONE WASHED

Stone Washed accessories

ZUPPIERA

Soup bowl - Soupière - Suppenterrine - Sopera
Cod. 539905..

Ø cm	h cm	Lt	Euro
18	10	1,5	63,76
22	12	3	78,18
24	13	4	90,54
26	14	4,75	105,68
28	15	6	113,20



COPERCHIO PER ZUPPIERA

Lid for soup bowl - Couvercle pour soupière - Deckel für Suppenterrine - Tapa para sopera
Cod. 539906..

Ø cm	Euro
18	44,82
22	51,40
24	57,58
26	65,82
28	75,10

CLOCHE SEMISFERICA CON POMOLO

Semispheric cloche with knob - Cloche hémisphérique avec pommeau
Speiseglocke kugelförmig mit Griff - Cloche semiesferica con pomo
Cod. 539992..

Ø cm IN	h cm	for round tray Ø cm	Euro
22	12	30	60,26
24	13	30	66,86
26	14	35	77,66
28	15	35	85,70



SALSIERA CON BASE

Sauce boat with foot - Saucière sur pied - Sauciere mit Fuß - Salsera con base
Cod. 53998014

cl	Euro
14	20,70



SOTTOPIATTO BERNINI

Underplate - Sous-assiette - Platzteller - Bajo plato

Cod. 57072731

Ø cm	Euro
31	63,76



SOTTOPIATTO/VASSOIO TONDO CHIPPENDALE

Underplate - Sous-assiette - Platzteller - Bajo plato

Cod. 509W5332

Ø cm	Euro
32	60,68



SOTTOPIATTO/VASSOIO OVALE CHIPPENDALE

Underplate - Sous-assiette - Platzteller - Bajo plato

Cod. 509W5147

cm	Euro
47x32	78,94



CESTINO QUADRATO CHIPPENDALE

Bread basket - Corbeille à pain - Brotkorb - Cesto para el pan

Cod. 509W6022

cm	Euro
22	48,88



CESTINO TONDO CHIPPENDALE

Bread basket - Corbeille à pain - Brotkorb - Cesto para el pan

Cod. 509W6225

cm	Euro
25	51,40



CESTINI

Basket

CESTINO FRUTTA PROGETTO 1929

Fruit basket - Corbeille a agrumes - Obstkorb - Cesto para naranjas

Cod. 50914425

Ø cm	h cm	Euro
25	10	58,10



CESTINO PANE PROGETTO 1929

Bread basket - Corbeille à pain - Brotkorb - Cesto para el pan

Cod. 50914225

Ø cm	h cm	Euro
25	7	54,18



PORTAGRISINI PROGETTO 1929

Bread-stick holder - Porte-gressins - "Grissini" Halter - Porta colines

Cod. 50914309

Ø cm	h cm	Euro
9,6	16	39,36



CESTINO PANE TONDO BELLA BRA

Round bread basket - Corbeille à pain - Brotkorb - Cesto para el pan

Cod. 57761221

Ø cm	Euro
21	36,08



CESTINO PANE OVALE BELLA BRA

Oval bread basket - Corbeille à pain - Brotkorb - Cesto para el pan

Cod. 57761131

cm	Euro
21x31	48,18



SECCHIELLI

Bucket

SECCHIELLO CHAMPAGNE PITAGORA 1929

Champagne bucket - Seau à champagne

Sektkübel - Cubo de champán

Cod. 50954100

Ø cm	h cm	Euro
18	20	77,78



SECCHIELLO GHIACCIO CON MOLLA PITAGORA 1929

Ice bucket with ice tongs - Seau à glace avec pince

Eiskübel - Cubo de hielo

Cod. 50954000

Ø cm	h cm	Euro
12	12	53,06



SECCHIELLO CHAMPAGNE 4 Lt

DOPPIA PARETE BELLA BRA

Double walled Champagne bucket - Seau à glacechamp. avec double parois

Sektkübel doppelwandig - Cubo champañã doble pared

Cod. 55765804

Ø cm	h cm	Lt	Ø cm fondo	Euro
20,8	21	4	19	100,90



SECCHIELLO CHAMPAGNE Lt 7

DOPPIA PARETE BELLA BRA

Double walled Champagne bucket - Seau à glacechamp. avec double parois

Sektkübel doppelwandig - Cubo champañã doble pared

Cod. 55765907

Ø cm	h cm	Lt	Ø cm fondo	Euro
25,5	22,5	7	19,6	166,18



SECCHIELLO CHAMPAGNE 4 Lt BELLA BRA
 Champagne bucket - Seau à champagne
 Sektkübel - Cubo de champan
 Cod. 55765004

Ø cm	h cm	Lt	Ø cm fondo	Euro
21	20,2	4	18,8	57,04



SECCHIELLO CHAMPAGNE 7 Lt BELLA BRA
 Champagne bucket - Seau à champagne
 Sektkübel - Cubo de champan
 Cod. 55765307

Ø cm	h cm	Lt	Ø cm fondo	Euro
25,5	22,5	7	19,5	95,24



PORTA GHIACCIO DOPPIA PARETE
 CON SEPARATORE BELLA BRA
 Double walled icebox with divider
 Seau à glace double paras avec separateur
 Eiskuebel doppelwandig mit einsatz
 Porta hielo doble pared con separador
 Cod. 55766400

Ø cm	Euro
15	93,52



COLONNA PORTA SECCHIELLO BELLA BRA
 Champagne bucket stand - Colonne porte-seau
 Sektkühlerständer - Porta cubos
 Cod. 55765600

h cm	Euro
62	130,30



COLONNA PORTA SECCHIELLO PITAGORA 1929

Champagne bucket stand - Colonne porte-seau

Sektkühlerständer - Porta cubos

Cod. 50954300

h cm	Euro
64	112,80



SECCHIELLO CHAMPAGNE LATINA BRA

Champagne bucket - Seau à champagne

Sektkübel - Cubo de champan

Cod. 50955218

Ø cm	h cm	Euro
18	18	41,74



SEPARATORE BRA

Separator - Separateur

Einsatz für Sektkuebel - Separador

Cod. 50955000

Euro 17,54



SECCHIELLO CHAMPAGNE LATINA BRA

Champagne bucket - Seau à champagne

Sektkübel - Cubo de champan

Cod. 50955222

Ø cm	h cm	Ø cm fondo	Euro
22	22	17,5	54,90



SECCHIELLO GHIACCIO LATINA BRA

Ice bucket - Seau à glace

Eiskübel - Cubo de hielo

Cod. 50955300

Ø cm	h cm	Euro
10	11,5	27,08



OLIERE

INOX
18/10

Cruet

OLIERA 5 PEZZI NOUVELLE CUISINE
5 pc cruet set - Ménagère 5 pièces
Menage 5 Tlg - Vinagreras 5 piezas
Cod. 50943305

cm - h cm	Euro
17,1x14,5x20,5	71,28



OLIERA 2 PEZZI NOUVELLE CUISINE
2 pc cruet set - Ménagère 2 pièces
Menage 2 Tlg - Vinagreras 2 piezas
Cod. 50943302

cm - h cm	Euro
15X9,2X20,5	45,42



SALE/PEPE E PORTASTECCHI NOUVELLE CUISINE
Salt /pepper and toothpicks set - Set à sel/poivre et cure dents
Salz und Pfefferstreuer und Zahnstocherf - Salero con palillo
Cod. 50943510

cm - h cm	Euro
11,5x10x12	46,88



OLIERA SALE/PEPE 4 PEZZI
NOUVELLE CUISINE
4 pc cruet salt/pepper set
Ménagère avec sel et poivre
Menage 4 Tlg mit Pfeffer/Salz
Vinagreras con pimentero y salero
Cod. 50943304

cm - h cm	Euro
20x12,2x20,5	58,40

OLIERA SALE/PORTASTECCHI 4 PEZZI
NOUVELLE CUISINE
4 pc cruet salt/toothpick set
Ménagère avec saliere et cure-dents
Menage mit Salz und Zahnstocherfl
Vinagreras con salero y palillos
Cod. 509433A4

cm - h cm	Euro
20x12,2x20,5	61,30



SALE/PEPE NOUVELLE CUISINE
Salt and pepper set - Set à sel et poivre
Menage Salz und Pfefferstreuer - Salero y pimen
Cod. 50943500

cm - h cm	Euro
11x6,8x13,5	27,82

SALE/PORTASTECCHI NOUVELLE CUISINE
Salt and toothpicks set - Set à sel et cure dents
Menage Salz und Zahnstocherfl - Salero y porta palillos
Cod. 509435A0

cm - h cm	Euro
11x6,8x13,5	27,82



FORMAGGERA CON CUCCHIAINO NOUVELLE CUISINE

Cheese bowl with cheese spoon - Fromagère avec cuillère à parmesan

Käsedose mit Käselöffel - Quesera con cuchara

Cod. 50943400

Ø cm - h cm	Euro
11,6x6,8	26,88



OLIERA 4 PEZZI PROGETTO 1929

4 pc cruet set - Ménagère 4 pièces

Menage 4 Tlg - Vinagreras 4 piezas

Cod. 50944404

cm - h cm	Euro
18,5x8,8x21,5	63,76



FORMAGGERA PROGETTO 1929

Cheese bowl - Fromagère

Käsedose - Quesera

Cod. 50944600

Ø cm - h cm	Euro
10x8	30,80



OLIERA 4 PEZZI PITAGORA 1929
4 pc cruet set - Ménagère 4 pièces
Menage 4 Tlg - Vinagreras 4 piezas
Cod. 50942600

Ø cm - h cm	Euro
17,3x24,3	82,82



FORMAGGERA PITAGORA 1929
Cheese bowl - Fromagère
Käsedose - Quesera
Cod. 50942700

Ø cm - h cm	Euro
11x12,3	35,02



SALE/PEPE BELLA BRA
Salt and pepper set - Set à sel et poivre
Menage Salz und Pfefferstreuer - Salero y pimeno
Cod. 57767202
Euro 21,46







C O T T U R A

C o o k i n g

C u i s s o n

K ü c h e n

C o c c i ò n



Gas
Gas
Gaz
Gas
Gas



Elettriche a piastra
Electricity solid hob
Plaque électrique
Elektrische Platteheizung
Electrica lisa

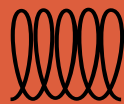

Induzione
Induction
Induction
Induktion
Induccion



Elettriche a spirale
Electricity radiant ring
Plaque électrique à spirales
Elektrische Spiralheizung
Electrica con espirales



Vetroceramica
Electricity Radiant plate
in glass ceramic
Vitrocéramique
Ceran
Vitroceramica



Forno
Oven
Four
Ofen
Horno



3 LAYERS 3730

Trimetallo - 3Ply

Made in Italy 

NEW



-Materiale innovativo multistrato ad alta conducibilità di calore, composto da:

- › Parete interna in Acciaio Inox 18/10 Aisi 304
- › Strato intermedio in alluminio termo-diffusore
- › Parete esterna in Acciaio Inossidabile ferritico adatto a tutte le fonti di calore, induzione compresa

- Finitura satinata interna ed esterna
- Parete e fondo a spessore costante
- Bordo rompigoccia a versare
- Maniglie e manici tubolari atermici in acciaio inox 18/10
- Rivetti di fissaggio in acciaio inox ad alta resistenza
- Indicato per cotture e conservazione prolungata degli alimenti a qualunque temperatura
- Lavabile in lavastoviglie

-3 layers high conductivity material made of

- › *18/10 interior cooking surface*
- › *Aluminium heat diffuser inner core to spread heat evenly through the pan base and side walls*
- › *18/0 magnetic stainless steel exterior suitable for all heating sources including induction hobs*

- *Satin finish inside and outside*
- *Base and side walls with even thickness*
- *Rim for clean, easy, non-drip pouring*
- *"stay-cool" stainless steel tube handles*
- *Handles with stainless steel extra strong rivets*
- *Dishwasher safe*

3 LAYERS



CASSERUOLA FONDA 2 MANIGLIE

Deep casserole - Casserole avec 2 poignées - Fleischtopf - Cacerola honda 2 mangos
Cod. 373005..

Ø cm	h cm	Lt	Euro
20	12	3,75	52,74
24	14	6,25	67,18
28	16	9,75	79,04
32	18	14,5	111,18



CASSERUOLA MEZZA FONDA 2 MANIGLIE

Low casserole - Casserole mi-haute avec 2 poignées - Bratentopf - Cacerola baja 2 mangos
Cod. 373009..

Ø cm	h cm	Lt	Euro
20	7,5	2,25	50,46
24	9,5	4,25	60,84
28	11	6,75	72,60
32	13	10,5	94,86
36	14,5	14,75	126,46



CASSERUOLA FONDA 1 MANICO

Saucepan - Casserole haute avec manche - Stielkasserolle - Cazo con mango
Cod. 373006..

Ø cm	h cm	Lt	Euro
16	10	2	43,26
20	12	3,75	57,42
24	14	6,25	75,40



3 LAYERS

PADELLA SAUTÉ CON MANICO

Sauté Frying pan - Sauteuse - Stielpfanne Sauté - Sarten Sauté

Cod. 37303B..

Ø cm	h cm	Euro
20	4,3	43,00
24	5	49,20
28	5,7	58,56
32	6	69,16
36	7	90,50



PADELLA SAUTÉ ANTIADERENTE CON MANICO

Non-stick Sauté pan - Sauteuse antiadhérente - Antihftbeschichtete Pfanne
"Sauté" mit Stiel - Sartén salud antiadherente con mango

Cod. 37313B..

Ø cm	h cm	Euro
20	4,3	58,90
24	5	67,30
28	5,7	77,18
32	6	99,90
36	7	114,90



COPERCHI COMPATIBILI: serie Tender pag. 189 - Serie Expo Satinato pag. 181
COMPATIBLE LIDS: Tender line pag. 189 - Expo Satinato line pag.181



CARATTERISTICHE TECNICHE

Prova di carico per pentole Catering Expo

PROVA DI CARICO PER
PENTOLA MOD. CATERING

MISURA 40
CAPACITÀ CONVENZ: 30 LITRI

Condizioni di prova

- 1) forza verticale applicata alle impugnature
- 2) forza verticale applicata ad UNA impugnatura

Coefficienti di calcolo

a) efficienza delle saldature: 0.75

b) coefficiente di sicurezza rispetto
alla tensione di rottura:

$k=5$ per le tensioni semplici

$k=25$ per le tensioni composte

c) coefficiente di sicurezza rispetto
al carico di MASSIMO RIEMPIMENTO:

$k=5$ nelle condizioni 1 e 2

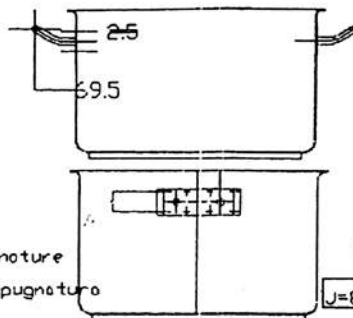

materiale: AISI 304
tensione di rottura $R_m = 500 \text{ Nmm}^{-2}$
tensione ammissibile $\sigma_{ann} = 100 \text{ Nmm}^{-2}$

$K=5$ OK

sezione resistente: 8 punti di saldatura $D=2.5 \text{ mm}$
 $A = \pi \times (0.75 \times D^2) / 4 = 2.76 \text{ mm}^2$

$$A_{tot} = 8 \times 2.76 = 22 \text{ mm}^2$$

momento d'inerzia (per $d = 0.75 \text{ D} = 1.875 \text{ mm}$)

$$J = 8 \times \pi \times (r^4 / 4 + r^2 \times l^2) = 6403 \text{ mm}^4$$

modulo di resistenza

$$W = J / l = 376.6 \text{ mm}^3$$

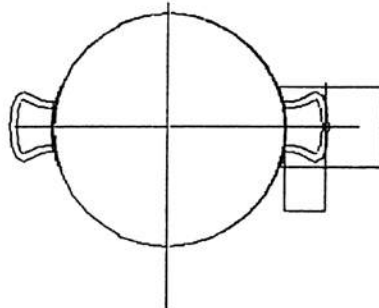

CONDIZIONE 3

CAPACITÀ DEL RECIPIENTE: 29 LITRI

condizioni di riempimento: 50% acqua
50% altro
peso specifico medio: acqua = 1
altro = 2

carico totale

$$1 \times 14.5 + 2 \times 14.5 = 44.5 \text{ N}$$

In condizione 1

$$k = 4.6 \times 542 / 44.5 = 5.6 \text{ OK}$$

In condizione 2

$$k = 2.96 \times 1506 / 44.5 = 10 \text{ OK}$$

CONDIZIONE 1 $K=5$ OK

momento flettente ammissibile

$$M_{f,ann} = \sigma_{ann} \times W = 100 \times 376.6 = 37660 \text{ Nmm}$$

carico ammissibile corrispondente

$$V = M_{f,ann} / b = 37660 / 69.5 = 542 \text{ N}$$

tensione di taglio corrispondente

$$\tau = V / A_{tot} = 542 / 22 = 24.6 \text{ Nmm}^{-2}$$

tensione composta

$$\sigma_{tot} = (\sigma_{ann}^2 + 3 \tau^2)^{1/2} = 108.7 \text{ Nmm}^{-2}$$

$K=4.6$ OK

CONDIZIONE 2

momento flettente ammissibile

$$M_{f,ann} = 37660 \text{ Nmm}$$

carico ammissibile

$$N = 37660 / 25 = 1506 \text{ N}$$

tensione di trazione corrispondente

$$\sigma_N = N / A_{tot} = 68.5 \text{ Nmm}^{-2}$$

tensione composta

$$\sigma_{tot} = \sigma_N + \sigma_{ann} = 168.5 \text{ Nmm}^{-2}$$

$k = 500 / 168.5 = 2.96$ OK

1. MANIGLIE

Sono anatomiche in tondo d'acciaio inossidabile. Pentole e casseruole sono dotate di una speciale flangia di rinforzo alle maniglie, con 10 punti di saldatura i manici dei tegami sono in tubolare ovale, leggero e robusto.

1. HANDLES

Ergonomically designed tubular stainless steel. Casseroles and pans are fitted with special handle reinforcement flanges, each welded at 10 points. Handles for pans are in robust oval tube.



2.BORDO SUPERIORE

É indurito a freddo per evitare l'ovalizzazione dei pezzi. Bordo a versare rompigoocia.

2.TOP EDGE

A cool-folding of the pouring-off edge prevents ovality of the pans'body.



3.FONDO TERMODIFFUSORE INDUZIONE

Con piastra d'alluminio di elevato spessore. Con calotta sandwich di protezione in acciaio. Fondo concavo a freddo, piano a caldo per aiutare la planarità. Adatto per cucine elettriche, a gas, vitroceramica e induzione.

3.SANDWLCH BOTTOM

Fitted with extra thick aluminium plate with steel protective cover and steel protection disk on larger pans. Bottom is specially designed to make the pan as stable as possible. Suitable for electric, gas, ceramic hobs and induction.



4.MANICI

I manici sono in tubolare per un'ottima presa e saldati con flangia di rinforzo.

4.HANDLES

Handles are made of tubular steel with a strong grip and are welded with a reinforcing flange.





EXPO SATINATO 3060

Acciaio Inox 18/10 - Stainless steel 18/10



È la classica serie professionale che racchiude tutte le caratteristiche fondamentali richieste dai migliori cuochi.

-Il fondo termodiffusore sandwich (ACCIAIO-ALLUMINIO-ACCIAIO) favorisce un'uniforme diffusione del calore.

-La calotta in materiale ferritico, può essere usata sulle piastre ad induzione.

-Le maniglie con flangia di rinforzo, resistono ad una trazione di 400 kg.

- Il bordo incrudito a freddo mantiene la rotondità dei bordi evitando l'ovalizzazione.

-Il coperchio piano con una leggera tolleranza facilita la fuoriuscita del vapore in eccesso.

-La forte satinatura mantiene nel tempo un aspetto integro ed ordinato.

-Indispensabile per coloro che utilizzano la normativa HACCP.

This is the classical professional series which has all the fundamental characteristics that the best chefs demand.

-A sandwich thermal-diffusion bottom (STEEL-ALUMINUM-STEEL) gives an even distribution of heat.

-The ferritic material cover can be used on the induction plates.

-The handles with reinforcement flange resist traction of 400 kg.

-The work hardened border keeps the borders round, avoiding out-of-round.

-The flat cover with a slight tolerance allows excess vapor to escape.

-A strong satin glazing keeps it looking in good order and integral over time.

-It is indispensable for those who abide by the HACCP norm.

PENTOLA

Pot - Marmite - Suppentopf - Olla

Cod. 306003..

Ø cm	h cm	Lt	Euro
20	20	6¼	65,94
24	24	10¾	81,34
28	25	15¼	106,40
30	30	21¼	131,46
32	32	25¾	147,48
34	34	30¾	166,72
36	36	36½	193,14
40	38	47¾	218,20
45	45	71½	304,42



CASSERUOLA FONDA 2 MANIGLIE

Deep casserole - Casserole avec 2 poignées - Fleischtopf - Cacerola honda 2 mangos

Cod. 306005..

Ø cm	h cm	Lt	Euro
20	12	3¾	52,74
24	14	6¼	67,18
28	16	9¾	79,04
30	17	12	87,68
32	18	14½	111,18
34	19	17¼	121,78
36	21	21¼	138,64
40	23	28¾	161,30
45	26	41¼	188,46
50	30	58¾	245,86



CASSERUOLA MEZZA FONDA 2 MANIGLIE

Low casserole - Casserole mi-haute avec 2 poignées - Bratentopf - Cacerola baja 2 mangos

Cod. 306009..

Ø cm	h cm	Lt	Euro
24	9,5	4¼	60,84
28	11	6¾	72,60
30	12	8½	81,96
32	13	10½	94,86
34	13,5	12¼	114,72
36	14,5	14¾	126,46
40	16	20	145,18
45	18	28½	167,44
50	20	39¼	210,70



CASSERUOLA MEZZA FONDA CON MANICO

Deep casserole - Casserole avec 1 manche - Fleischtopf - Cacerola honda 1 mangos

Cod. 306010..

Ø cm	h cm	Lt	Euro
16	7,5	1¼	40,56
20	8,5	2¼	49,20
24	9,5	4¼	59,70



CASSERUOLA FONDA CON MANICO

Saucepan - Casserole haute avec manche - Stielkasserolle - Cazo con mango

Cod. 306006..

Ø cm	h cm	Lt	Euro
16	10	2	43,26
20	12	3¾	57,42



CASSERUOLA FONDA CON MANICO E MANIGLIA

Saucepan - Cass. haute avec manche et poignée - Stielkasserolle mit Griff - Cazo con mango y asa

Cod. 306007..

Ø cm	h cm	Lt	Euro
24	14	6¼	75,40
28	16	9¾	87,58



CASSERUOLA CONICA PESANTE

Conical casserole - Casserole conique - Konische Kasserolle, schwere Ausführung
- Cacerola conica

Cod. 306012..

Ø cm	h cm	Lt	Euro
16	6	1	38,38
18	6,5	1 $\frac{1}{3}$	43,26
20	7	1 $\frac{3}{4}$	50,34
24	7,5	2 $\frac{3}{4}$	59,60



TEGAME 2 MANIGLIE

Frying pan 2 handles - Poêle avec 2 poignées - Pfanne mit 2 Griffen - Rustidera
2 mangos

Cod. 306023..

Ø cm	h cm	Euro
24	5	61,36
28	5,7	73,32
30	6	79,66
32	6	84,98
34	6	93,92
36	7	101,50
40	7,5	111,38
45	8	147,48
50	9	168,38



PADELLA CILINDRICA

Frying pan - Poêle avec manche - Stielpfanne mit Griff - Sarten con mango

Cod. 306026..

Ø cm	h cm	Euro
24	5	61,36
28	5,7	73,32



PADELLA CILINDRICA

Frying pan with counter handle - Poêle avec manche et poignée - Stielpfanne mit Griff - Sarten con mango y asa

Cod. 306026..

Ø cm	h cm	Euro
30	6	84,56
32	6	92,04
34	6	100,98
36	7	108,48
40	7,5	119,18
45	8	154,54



PADELLA SAUTÉ CON MANICO RIVETTATO

Sauté Frying pan - Sauteuse - Stielpfanne Sauté - Sarten Sauté

Cod. 30673B..

Ø cm	h cm	Euro
24	5	49,20
28	5,7	58,56
30	6	62,10



IN ESAURIMENTO / DISCONTINUED

Sostituito da articolo pag 190

Replaced by product on page 190

PADELLA SAUTÉ ANTIADERENTE CON MANICO

Non-stick Sauté pan - Sauteuse antiadhérente - Antihftbeschichtete Pfanne "Sauté" mit Stiel - Sartén salud antiadherente con mango

Cod. 30613B..

Ø cm	h cm	Euro
24	5	67,30
28	5,7	77,18
30	6	84,86



IN ESAURIMENTO / DISCONTINUED

Sostituito da articolo pag 190

replaced by product on page 190

PADELLA ANTIADERENTE CON MANICO E MANIGLIA

Non-stick frypan with counter handle - Poêle antiadhérente avec manche et poignée - Antihafbeschichtete Pfanne mit Stiel und Griff - Sartén antiadherente con mango y asa

Cod. 306126..

Ø cm	h cm	Euro
32	6	121,16
34	6	131,88
36	7	141,34
40	8	157,46



TEGAME ANTIADERENTE 2 MANIGLIE

Non-stick Frying pan 2 handles - Poêle antiadhérente avec 2 poignées - Antihafbeschichtete Pfanne mit 2 Griffen - Rustidera antiadherente 2 mangos

Cod. 306123..

Ø cm	h cm	Euro
32	6	119,92
34	6	135,30
36	7	139,98
40	8	157,46



COPERCHIO

Lid - Couvercle - Deckel - Tapa

Cod. 306030..

Ø cm	Euro
20	14,46
24	16,34
28	19,46
30	21,64
32	25,48
34	28,40
36	31,42
40	37,44
45	43,26
50	51,90





TENDER

3390

Acciaio inox 18/10 - Stainless steel 18/10

Made in Italy 



La serie Tender è studiata per rispondere alle esigenze delle comunità ed enti, è particolarmente indicata per tutte le gare d'appalto.

Le caratteristiche principali sono:

- Bordo ribordato e rinforzato.
- Corpo in acciaio inox 18/10 AISI 304.
- Maniglie tubolari anticalore.
- Fondo termo diffusore adatta anche all'utilizzo su piastra a induzione.

This new Tender series is perfect for the Communities necessities and for all the Professional kitchens use like in the Hospitals, Hotels, Restaurants and more.

Fundamentals characteristics:

- Border is reinforced and reflanged.
- Body is in AISI 304 (18/10) stainless steel.
- Tube pipe side handles in stainless steel heatsink.
- A sandwich thermal-diffusion bottom (steel/ aluminium/steel) suitable for induction.



Etichetta personalizzata per la linea Tender

Tender Custom label



INOX
18/10

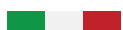

TENDER SPEEDY-PASTA

CUOCIPASTA COMPLETO

4 SETTORI

Composto da:

1 pentola, 1 coperchio,

1 settore lungo,

3 settori corti

Pasta pot :

1 pot, 1 lid,

1 long section colander

3 short section colanders

Cuiseur de pâtes:

1 marmite, 1 couvercle,

1 Secteur cuit-pâtes long,

3 Secteur cuit-pâtes court

Nudelkocher:

1 Suppentopf, 1 Deckel,

1 Nudelsiebeinsatz lang,

3 Nudelsiebeinsatz kurz

Cuece-pasta:

1 Olla, 1 Tapa,

1 Sector colador alto,

3 Sector colador bajo

Cod. 3390Q404



cm ingombro	h cm	Euro
70x38	29	388,62

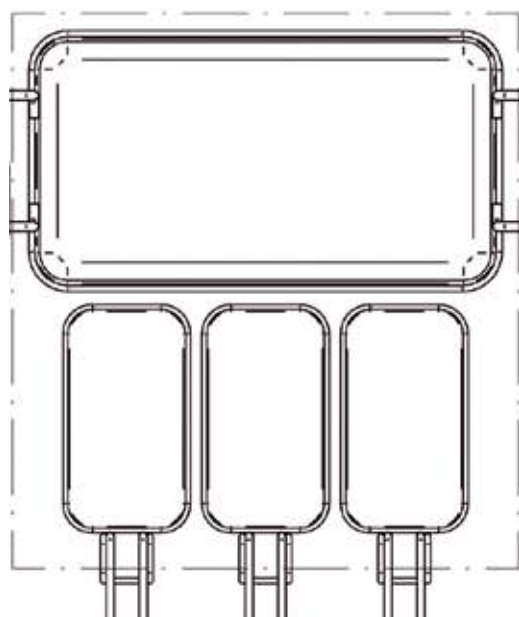

TENDER SPEEDY-PASTA

INOX
18/10

CUOCIPASTA COMPLETO

6 SETTORI

Composto da: 1 pentola, 1 coperchio, 6 settori corti

Pasta pot: 1 pot, 1 lid, 6 short section colanders

Cuiseur de pâtes: 1 marmite, 1 couvercle, 6 Secteur cuit-pates court

Nudelkocher: 1 Suppentopf, 1 Deckel, 6 Nudelsiebeinsatz kurz

Cuece-pasta: 1 Olla, 1 Tapa, 6 Sector colador bajo

Cod. 3390Q406

cm	h cm	Euro
70x38	29	431,90

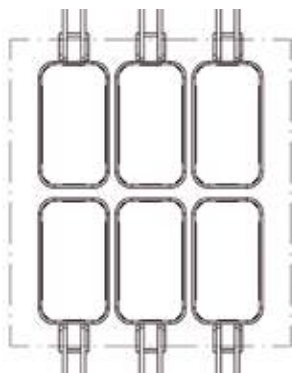

CUOCIPASTA COMPLETO

2 SETTORI

Composto da: 1 pentola, 1 coperchio, 2 settori lunghi

Pasta pot: 1 pot, 1 lid, 2 long section colanders

Cuiseur de pâtes: 1 marmite, 1 couvercle, 2 Secteur cuit-pates long,

Nudelkocher: 1 Suppentopf, 1 Deckel, 2 Nudelsiebeinsatz lang,

Cuece-pasta: 1 Olla, 1 Tapa, 2 Sector colador alto

Cod. 3390Q402

cm	h cm	Euro
70x38	29	345,36

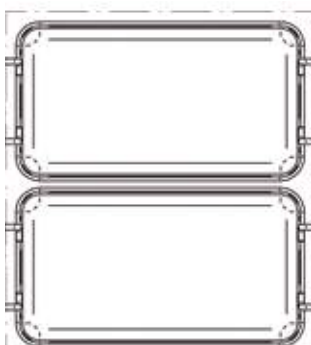

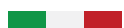

PENTOLA QUADRATA

Pot - Marmite - Suppentopf - Olla
Cod. 3390Q334

cm	h cm	Ø cm fondo	Lt	Euro
38,3x35,4	23,7	24,5	22	119,08



COPERCHIO CON SPACCO

Lid - Couvercle - Deckel - Tapa
Cod. 3390QS34

cm	h cm	Euro
35,5x32,5	9,4	61,74



SETTORE GRANDE

Long section colander - Secteur cuit-pates long
Nudelsiebeinsatz lang - Sector colador alto
Cod. 3390Q9A1

cm	h cm	Lt	n. persone <i>n. people</i>	Euro
30x14	18	6,6	6	83,38



SET 3 SETTORI PICCOLI

Short section colander - Secteur cuit-pates court
Nudelsiebeinsatz kurz - Sector colador bajo
Cod. 3390Q9A3

cm	h cm	Lt	n. persone <i>n. people</i>	Euro
14x10,5	18	2,3	1-2	132,10



TENDER

INOX
18/10



PENTOLA

Pot - Marmite - Suppentopf - Olla

Cod. 339003..

Ø cm	h cm	Lt	Euro
20	18	5,50	43,58
24	24	10,75	54,30
28	28	17,00	71,14
30	30	21,25	81,86
32	32	25,75	99,22
34	34	30,75	118,88
36	36	36,50	137,70
40	40	50,25	157,04
45	40	63,50	192,20



CASSERUOLA FONDA 2 MANIGLIE

Deep casserole - Casserole avec 2 poignées - Fleischtopf - Cacerola honda 2 mangos

Cod. 339005..

Ø cm	h cm	Lt	Euro
20	12	3,75	36,20
24	14,5	6,25	48,78
28	16	9,75	53,56
30	17	12,00	62,82
32	19,5	15,70	80,08
36	21,5	21,25	100,36
40	24	30,00	115,96
45	27	42,75	147,16
50	30	58,75	187,72



CASSERUOLA MEZZA FONDA 2 MANIGLIE

Low casserole - Casserole mi-haute avec 2 poignées - Bratentopf - Cacerola baja 2 mangos

Cod. 339009..

Ø cm	h cm	Lt	Euro
24	8	3,50	41,30
28	9,5	5,75	50,66
32	11	8,75	69,78
36	13	13,25	92,26
40	14,5	18,00	106,82
45	15,5	25,40	127,50
50	19	37,25	171,70



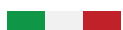

CASSERUOLA MEZZA FONDA CON MANICO

Deep casserole - Casserole avec 1 manche - Fleischtopf - Cacerola honda 1 mangos
Cod. 339010..

Ø cm	h cm	Lt	Euro
16	6,5	1,25	25,06
20	7,5	2,25	31,20
24	8	3,50	39,94
28	9,5	5,75	49,24
32	11	8,75	67,82



CASSERUOLA FONDA CON MANICO

Saucepan - Casserole haute avec manche - Stielkasserolle - Cazo con mango
Cod. 339006..

Ø cm	h cm	Lt	Euro
16	9,5	2,00	27,14
20	12	3,75	35,98



CASSERUOLA FONDA CON MANICO E MANIGLIA

Saucepan - Cass. haute avec manche et poignée - Stielkasserolle mit Griff - Cazo con mango y asa
Cod. 339007..

Ø cm	h cm	Lt	Euro
24	14,5	6,25	49,92
28	16	9,75	54,92
32	19,5	15,7	82,50



CASSERUOLA CONICA

Conical casserole - Casserole conique - Konische Kasserolle, schwere Ausführung - Cacerola conica
Cod. 339012..

Ø cm	h cm	Lt	Euro
16	6	1,00	23,20
18	6	1,33	26,00
20	6,5	1,75	29,54
24	7,5	2,75	32,46



PADELLA CILINDRICA

Frying pan - Poêle avec manche - Stielpfanne mit Griff - Sarten con mango
Cod. 339025..

Ø cm	h cm	Euro
24	5	36,92
28	5,5	45,76



PADELLA CILINDRICA CON MANICO E MANIGLIA

Frying pan with counter handle - Poêle avec manche et poignée - Stielpfanne mit Griff - Sarten con mango y asa

Cod. 339026..

Ø cm	h cm	Euro
32	6	66,26
36	6	82,78
40	6	94,34
45	8	116,48



TEGAME 2 MANIGLIE

Frying pan 2 handles - Poêle avec 2 poignées - Pfanne mit 2 Griffen - Rustidera 2 mangos

Cod. 339023..

Ø cm	h cm	Euro
24	5	48,98
28	5,7	59,08
32	6	65,84
36	6	81,22
40	6	88,20
45	8	118,14
50	8	133,44



COPERCHIO INOX 18/0

Lid - Couvercle - Deckel - Tapa

Cod. 339030..

Ø cm	Euro
20	9,68
24	10,40
28	11,96
30	12,80
32	14,36
34	15,40
36	16,22
40	18,62
45	21,84
50	25,06



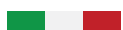

PADELLA SAUTÉ CON MANICO RIVETTATO

Sauté Frying pan - Sauteuse - Stielpfanne Sauté - Sarten Sauté

Cod. 33903B..

Ø cm	h cm	Euro
20	4,3	42,90
24	5	49,20
28	5,7	58,56
30	6	62,10
32	6	70,90
36	7	79,90



NEW

PADELLA SAUTÉ ANTIADERENTE CON MANICO

Non-stick Sauté pan - Sauteuse antiadhérente - Antihftbeschichtete Pfanne
"Sauté" mit Stiel - Sartén salud antiadherente con mango

Cod. 33913B..

Ø cm	h cm	Euro
20	4,3	58,90
24	5	67,30
28	5,7	77,18
30	6	84,86
32	6	99,90
36	7	114,90



NEW





TENDER ALU 3500

Alluminio - Aluminum

Made in Italy 



- Serie professionale completa per il settore HORECA.
- Tutti gli articoli sono prodotti con alluminio puro al 99,5% idoneo al contatto alimentare.
- I manici e le maniglie sono in tubolare d'acciaio inox 18/10 atermico e applicati con rivetti.
- Nickel Free.
- Ottimo per: cottura al salto, cotture lente e a fuoco moderato, cottura a parete.
- La forma di pentole e casseruole le rende impilabili.
- Per conservare il colore dell'alluminio è consigliato non lavare in lavastoviglie.

- Complete professional series for HORECA.*
- All the items are made in 99,5% pure Aluminium suitable for contact with food.*
- Riveted 18/10 (AISI 304) tubular stainless steel 18/10 (AISI 304) Handles and knobs.*
- Nickel Free.*
- Suitable for: Cuisson a sauter, Slow cooking, Browning.*
- Stockable pots and casseroles.*
- To preserve the color of aluminum is recommended do not wash in the dishwasher.*



PENTOLA

pot

Cod. 350003..

Ø cm	h cm	lt	Euro
20	19	4,8	35,46
24	22	8,4	38,62
28	26	13,8	46,22
30	28	17,2	50,30
32	30	21,2	52,00
36	33	29,9	67,90
40	37	41,9	77,90
45	40	58,1	116,00
50	45	81,4	132,00
60	56	147,9	189,90



CASSERUOLA FONDA

deep casserole

Cod. 350005..

Ø cm	h cm	lt	Euro
20	11	3,0	27,90
24	14	5,6	31,80
28	16	8,8	34,90
30	17	10,8	43,90
32	18	13,1	46,90
36	18	18,7	50,20
40	20	25,6	54,50
45	25	37,1	84,90
50	28	51,7	106,90
60	35	94,0	121,90



CASSERUOLA BASSA

Low casserole

Cod. 350009..

Ø cm	h cm	lt	Euro
20	7	2,0	24,90
24	8	3,3	28,90
28	9	5,2	34,50
32	10	7,5	42,20
36	12	11,5	47,20
40	13	15,5	52,64
45	15	22,8	72,60
50	17	32,0	82,30
60	20	54,7	96,70



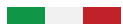

CASSERUOLA FONDA 1 MANICO

deep saucepan

Cod. 350006..

Ø cm	h cm	lt	Euro
16	8	1,3	19,50
20	11	3,0	22,30
24	14	5,6	25,90
28	16	8,8	30,30
30	17	10,8	37,60
32	18	13,1	42,50



CASSERUOLA BASSA 1 MANICO

low saucepan

Cod. 350010..

Ø cm	h cm	lt	Euro
16	6	1,1	16,60
20	7	2,0	19,90
24	8	3,3	23,20
28	9	5,2	28,90
32	10	7,5	36,30



COPERCHIO

lid

Cod. 350030..

Ø cm	Euro
16	7,78
20	8,66
24	9,50
28	10,80
30	13,66
32	14,54
36	18,00
40	21,16
45	23,40
50	28,50
60	34,70



PADELLA BASSA **4 mm**

aluminum frynig pan

Cod. 374025..

Ø cm	h cm	lt	Euro
20	3,8	0,85	18,70
24	4,2	1,5	23,50
28	4,6	2,0	27,24
32	5,0	3,4	33,12
36	6,6	6,0	44,00
40	7,2	8,0	50,46
45	8,1	11,8	66,50



NEW

PADELLA ALTA **4 mm**

aluminum deep frynig pan

Cod. 3740C5..

Ø cm	h cm	lt	Euro
20	4,6	1,2	19,48
24	5,0	1,8	24,30
28	5,7	2,8	29,10
32	6,5	4,6	37,10
36	8,0	7,3	47,80
40	8,5	9,7	53,14
45	9,5	14,0	71,82



NEW



TENDER ECLISSE

3509

Alluminio - Aluminum

Made in Italy 

NEW



-Serie professionale completa per il settore HORECA.
-Tutti gli articoli sono prodotti in alluminio rivestito con copertura antiaderente WHITFORD ECLIPSE HB professionale, senza PFOA e idonea al contatto alimentare.

-I manici e le maniglie sono in tubolare d'acciaio inox 18/10 atermico e applicati con rivetti.

-Nickel Free.

-Ottimo per: cottura al salto, cotture lente e a fuoco moderato, cottura a parete.

-La forma di pentole e casseruole le rende impilabili.

-Per conservare il colore dell'alluminio è consigliato non lavare in lavastoviglie.

-Complete professional series for HORECA.

-All the items are made in Aluminium covered with non-stick coating WITHFORD ECLIPSE HB professional, PFOA free and suitable for contact with food.

-Riveted 18/10 (AISI 304) tubular stainless steel 18/10 (AISI 304) Handles and knobs.

-Nickel Free.

-Suitable for: Cuisson a sauter, Slow cooking, Browning.

-Stackable pots and casseroles.

-To preserve the color of aluminum is recommended do not wash in the dishwasher.



CASSERUOLA FONDA

deep casserole

Cod. 350905..

Ø cm	h cm	lt	Euro
20	11	3,0	42,60
24	14	5,6	55,78
28	16	8,8	63,84
32	18	13,1	78,64
36	20	18,7	90,90
40	22	25,6	106,20
45	25	37,1	127,80



CASSERUOLA BASSA

low casserole

Cod. 350909..

Ø cm	h cm	lt	Euro
20	7	2,0	44,76
24	8	3,3	48,32
28	9	5,2	59,28
32	10	7,5	71,10
36	12	11,5	81,48
40	13	15,5	90,46
45	15	22,8	108,50



TEGAME

Frying pan 2 handles

Cod. 350923..

Ø cm	h cm	lt	Euro
28	6,0	3,15	49,16
32	6,5	4,25	58,76
36	7,0	6,35	67,00
40	7,2	8,5	75,66
45	8,0	12,5	81,30
50	8,5	15,5	94,74
60	9,0	26,5	112,76



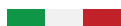

CASSERUOLA FONDA 1 MANICO

deep saucepan

Cod. 350906..

Ø cm	h cm	lt	Euro
16	8	1,3	36,38
20	11	3,0	38,46
24	14	5,6	49,40
28	16	8,8	56,60
32	18	13,1	71,90



CASSERUOLA BASSA 1 MANICO

low saucepan

Cod. 350910..

Ø cm	h cm	lt	Euro
16	6	1,1	33,34
20	7	2,0	36,00
24	8	3,3	43,38
28	9	5,2	52,00
32	10	7,5	64,28



PADELLA BASSA **4 mm**

aluminum non-stick frynig pan

Cod. 374925..

Ø cm	h cm	lt	Euro
20	3,8	0,85	31,76
24	4,2	1,5	37,38
28	4,6	2,0	45,40
32	5,0	3,4	53,14
36	6,6	6,0	69,16
40	7,2	8,0	77,16
45	8,1	11,8	117,48



NEW

PADELLA ALTA **4 mm**

aluminum non-stick deep frynig pan

Cod. 3749C5..

Ø cm	h cm	lt	Euro
20	4,6	1,2	32,56
24	5,0	1,8	37,90
28	5,7	2,8	46,74
32	6,5	4,6	55,80
36	8,0	7,3	70,50
40	8,5	9,7	78,78
45	9,5	14,0	121,98



NEW





TENDER TOTAL BLACK 374L

Alluminio - Aluminum

Made in Italy 

NEW



-Serie professionale per il settore HORECA.

-Tutti gli articoli sono prodotti in alluminio rivestito con copertura antiaderente WHITFORD ECLIPSE HB professionale, senza PFOA e idonea al contatto alimentare.

-NOVITÀ: rivestimento antiaderente esterno WHITFORD ECLIPSE HB professionale, senza PFOA.

-I manici sono in tubolare d'acciaio inox 18/10 atermico, applicati con rivetti e con copertura in silicone.

-Nickel Free.

-Ottimo per: cottura al salto, cotture lente e a fuoco moderato, cottura a parete.

-Professional series for HORECA.

-All items are made in Aluminium with non-stick coating WHITFORD ECLIPSE HB professional, PFOA free and suitable for contact with food.

-NEWS: External non-stick coating with WHITFORD ECLIPSE HB PROFESSIONALE, PFOA free.

-Riveted 18/10 (AISI 304) tubular stainless steel 18/10 (AISI 304) handles with a silicone covering.

-Nickel Free.

-Suitable for: Cuisson a sauter, Slow cooking, Browning.

TENDER TOTAL BLACK

ALLUMINIO
ALUMINUM



PADELLA BASSA **4 mm**

aluminum non-stick fryinig pan

Cod. 374L25..

Ø cm	h cm	lt	Euro
20	3,8	0,85	34,90
24	4,2	1,5	42,44
28	4,6	2,0	47,80
32	5,0	3,4	55,80
36	6,6	6,0	71,80
40	7,2	8,0	79,90



NEW

PADELLA ALTA **4 mm**

aluminum non-stick deep fryinig pan

Cod. 374LC5..

Ø cm	h cm	lt	Euro
20	4,6	1,2	38,18
24	5,0	1,8	45,12
28	5,7	2,8	50,46
32	6,5	4,6	63,80
36	8,0	7,3	74,50
40	8,5	9,7	85,16



NEW



TENDER ALU EASY 350

Alluminio - Aluminum



- Serie professionale per il settore HORECA.
- Tutti gli articoli sono prodotti con alluminio idoneo al contatto alimentare.
- I manici sono in tubolare d'acciaio inox 18/10 atermico e applicati con rivetti.
- Nickel Free.
- Ottimo per: cottura al salto, cotture lente e a fuoco moderato, cottura a parete.
- Antiaderente GREBLON COMPOUND professionale a 3 strati, **senza PFOA**.

- Professional series for HORECA.*
- All the items are made in Aluminum suitable for contact with food.*
- Riveted 18/10 (AISI 304) tubular stainless steel 18/10 (AISI 304) handles.*
- Nickel Free.*
- Suitable for: Cuisson a sauter, Slow cooking, Browning.*
- Non-stick coating Aluminium frying pans with GREBLON COMPOUND Professional 3 layers, **PFOA free.***

TENDER ALU EASY

PADELLA BASSA CON ANTIADERENTE GREBLON

aluminum non-stick frynig pan

Cod. 350925..

Ø cm	h cm	Lt	master	Euro
20	4,0	1,0	6	14,26
24	4,5	1,6	6	19,86
28	5,2	2,6	6	23,50
32	6,0	4,0	6	28,40
36	6,7	5,7	6	33,70
40	7,5	7,9	6	39,52
45	8,4	11,2	6	54,18



PADELLA ALTA CON ANTIADERENTE GREBLON

aluminum non-stick deep frynig pan

Cod. 3509C5..

Ø cm	h cm	Lt	master	Euro
20	4,7	1,2	6	15,08
24	5,4	2,0	6	21,00
28	6,3	3,3	6	25,48
32	7,2	5,0	6	30,16
36	8,1	7,1	6	37,14



PADELLA BASSA

aluminum frynig pan

Cod. 350025..

Ø cm	h cm	Lt	master	Euro
20	4,0	1,0	6	7,80
24	4,5	1,6	6	11,40
28	5,2	2,6	6	14,30
32	6,0	4,0	6	17,80
36	6,7	5,7	6	22,40
40	7,5	7,9	6	26,20
45	8,4	11,2	6	38,70



PADELLA ALTA

aluminum deep frynig pan

Cod. 3500C5..

Ø cm	h cm	Lt	master	Euro
20	4,7	1,2	6	8,40
24	5,4	2,0	6	12,40
28	6,3	3,3	6	15,70
32	7,2	5,0	6	19,30
36	8,1	7,1	6	24,20





EXCALIBUR 3610

Ferro - Iron

Made in Italy 

NEW



- Produzione made in Italy.
- Alto spessore.
- Prodotto in ferro (Fe).
- Adatto a tutti i tipi di cucina.
- Ottimo per l'induzione.
- Manico ergonomico in acciaio rivettato.
- Nickel Free.
- Linea professionale adatta per: frittura, cottura alla piastra, arrostitura, brasatura, caramellatura.

- Made in Italy.
- High tickness.
- Item made in steel (Fe).
- Suitable for all kind of cooktops.
- Perfect for Induction use.
- Riveted Ergonomic stainless steel handle.
- Nickel Free.
- Professional Series useful for: frying, grill cooking, oast cooking, brazing cooking, caramelization.

PADELLA
frying pan
Cod. 361054..

Ø cm	h cm	Lt	Euro
12 *	2,2	0,20	16,40
18 *	3,35	0,63	19,22
20	3,75	0,85	19,50
22 *	3,7	1,07	20,84
24	4	1,35	21,40
26	4,35	1,75	24,20
28	4,7	2,20	25,50
30 *	5	2,74	28,58
32	5,4	3,30	28,90
34	5,75	4,03	34,44



NEW *

PADELLA FONDA
deep frying pan
Cod. 3610C5..

Ø cm	h cm	Lt	Euro
24	7,65	2,70	29,64
28	8,6	4,15	37,90



NEW

TEGAME
frying pan 2 handles
Cod. 36102332

Ø cm	h cm	Lt	Euro
32	5,4	3,30	39,00



NEW

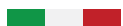

CREPIERE
crêpe frying pan
Cod. 361045..

Ø cm	h cm	Lt	Euro
20	1,25	0,36	19,22
24	1,5	0,60	21,10
28	1,75	0,90	24,56



NEW

WOK 2 MANIGLIE
wok with 2 handkes
Cod. 36109M36

Ø cm	h cm	Lt	Euro
36	11,9	7,1	74,00



WOK
wok
Cod. 36109F34

Ø cm	h cm	Lt	Euro
34	9,4	4,75	69,00



ESPOSITORE PER SERIE EXCALIBUR
Excalibur display
Cod. 99900149

largh.	prof.	altez.	Euro
48	48	204	490,00



NEW

Excalibur-Use instructions

Particolarmente versatili per la capacità del materiale di assicurare una temperatura uniforme e senza sbalzi in cottura, le padelle in ferro necessitano di una manutenzione specifica per conservarne inalterate le proprietà. Prima di tutto è necessario un pretrattamento per proteggerlo dall'ossidazione.

PRIMO UTILIZZO: BRUNITURA

-La padella va accuratamente lavata per qualche minuto con acqua calda e detersivo, in modo da rimuovere qualunque traccia dello strato protettivo con cui è venduta. Quindi va ben risciacquata e subito asciugata con uno strofinaccio e poi messa in forno a 70° finché non sarà completamente asciutta (in alternativa è possibile scaldarla su fiamma viva) e avrà assunto una colorazione grigia, tendente al blu.

-La padella di ferro teme gli sbalzi di temperatura, quindi abbiate l'accortezza di non inserirla nel forno già caldo e di farlo raffreddare all'interno del forno stesso.

-Con la padella ancora calda, passare con uno strofinaccio unto di olio di semi od altro olio da cucina.

-Passare poi la padella con un panno pulito, fino a quando non saranno rimosse tutte le tracce di olio e impurità.

-Rimettere la padella in forno a 70° (o su fiamma) per qualche minuto.

Al termine di questi passaggi non sarà più necessario lavare con acqua e detersivo la padella, ma sarà sufficiente pulirla ogni volta con carta assorbente o con uno straccetto unto. Qualora si rilevino tracce di sporco persistente procedere con le seguenti istruzioni. Con l'utilizzo l'articolo tende ad assumere una colorazione scura tendente al nero. Tale trasformazione superficiale è normale e conferisce al prodotto una proprietà antiaderente naturale. Tale patina contribuisce a proteggere la superficie dalla corrosione.

LAVAGGIO QUOTIDIANO:

-Lavare a mano con sola acqua calda, senza mai lasciarla in ammollo, eliminando i residui di cottura. In caso di residui incrostati utilizzare una spugna abrasiva. Asciugare immediatamente con un panno o carta assorbente.

-Ungere la padella con un panno unto di olio, e scaldare in forno a 70° (o su fiamma) per qualche minuto in modo da far asciugare lo strato d'olio. Lasciar raffreddare naturalmente.

-Conservare al riparo dall'umidità.

TRATTAMENTO DISINFETTANTE:

Saltuariamente trattare con il sale secondo le modalità seguenti. Tale trattamento serve per eliminare i residui delle cotture precedenti e gli odori, rendendo perfettamente secca la padella, con una leggera funzione abrasiva.

-Scaldare la padella con dell'olio, cospargerlo con sale grosso facendolo passare per 1 minuto e mezzo a fuoco vivo

-Strofinare la padella con della carta assorbente fino a eliminare i residui di cottura

-Scaldare di nuovo, ripetendo la procedura con del sale fino e strofinare nuovamente finché non risulterà pulito

-Scaldare ancora una volta la padella e ungerla con olio di semi od altro olio da cucina

-Riporre e conservare al riparo dell'umidità

N.B:

-Il nemico principale della padella in ferro è la ruggine. Per evitare l'ossidazione, mai lasciarla in ammollo nell'acqua.

-Il sale è una delle principali cause della corrosione, assicurarsi di rimuoverne qualunque traccia durante l'omonimo trattamento, o durante l'uso quotidiano.

-Non surriscaldare mai su piastra ad induzione, per non danneggiare padella e piastra.

-Surriscaldare, o raffreddare, l'articolo troppo velocemente può danneggiarlo.

-Alimenti acidi (alcolici, limoni, pomodori...) potrebbero danneggiare lo strato di brunitura, facendo comparire chiazze biancastre. Se avviene sarà sufficiente ripetere la procedura del primo utilizzo.

-La padella in ferro va mantenuta sempre un po' unta, in modo che non arrugginisca.

NON METTERE MAI IN LAVASTOVIGLIE!

Particularly versatile due to their material's capacity to guarantee uniform temperature without sudden temperature change, iron pans require specific maintenance to preserve their features. Firstly, they require pre-treatment to protect them against oxidation.

USING FOR THE FIRST TIME: BURNISHING

-Clean the pan thoroughly with hot water and detergent for a few minutes, so as to remove any residual protection layer it is sold with. Next, rinse thoroughly and dry immediately using a cloth, then place it in an oven at 70° until it dries completely (you may also heat it on an open flame) and turns bluish-grey.

-The iron pan is sensitive to sudden temperature changes, so do not place it on a previously heated oven. Leave it to cool inside the oven.

-Using a cloth, rub the pan while still hot using seed oil or any other cooking oil.

-Next, wipe the pan using a clean cloth until it is entirely free of any oil and dirt residues.

-Place the pan in the oven at 70° (or flame) again for a few minutes.

Once through with these steps, do not wash the pan with water and detergent again. All you have to do is clean using kitchen paper towel or an oily cloth. In case of stubborn dirt residue, do as follows: With the daily use the pan will naturally turn to black. This change of the surface will give the pan a kind of natural non-stick property. Moreover it would help to protect the surface from corrosion.

DAILY WASHING:

-Without leaving it to soak, hand-wash using hot water only to eliminate cooking residues. Use an abrasive sponge in case of burnt-on stains. Dry immediately using a cloth or kitchen paper towel.

-Oil the pan using an oily cloth, then heat in an oven at 70° (or open flame) for a few minutes to dry off the oil layer. Leave it to cool naturally.

-Keep away from moisture.

DISINFECTION:

Occasionally treat with salt as follows: This treatment helps eliminating previous cooking residues and odours, thus leaving the pan completely dry, with a slight abrasive function.

-Heat the pan using oil, sprinkle some coarse salt on it and leave it on an open flame for one and half minutes.

-Rub the pan using kitchen paper towel to eliminate cooking residues.

-Heat once again, repeating the procedure with fine salt and rub once again until it is completely clean

-Using a cloth, rub the pan once again using seed oil or any other cooking oil.

-Put it away and keep away from moisture

N.B:

-The iron pan is particularly sensitive to rust. Do not leave the pan soaked with water to avoid oxidation.

-Salt is one of the main causes of rust, hence ensure no traces of salt are left during the treatment using it or during daily use of the pan.

-Do not overheat on an induction plate to avoid damaging both the pan and induction plate.

-Too rapid heating and too rapid cooling may damage the pan.

-Acidic foodstuffs (alcohols, lemon, tomatoes...) they could damage the burnishing layer, thus causing whitish stains. Just repeat the "using for the first time" procedure if this happens.

-The iron pan must always be kept oiled to prevent rust.

DO NOT WASH IN DISHWASHER!



RAME Copper 3640

Rame 99% - Copper 99%

Stagno 99% - Tin 99%

Made in Italy 



- Produzione made in Italy.
- Rame puro al 99%
- Stagno puro al 99%
- Prodotta con materiali certificati e idonei al contatto alimentare.
- L'altissima conducibilità termica del rame garantisce un'ottima precisione nella regolazione della temperatura.
- Indispensabile nel settore della pasticceria.
- Altissimo risparmio energetico.
- Nickel free.

- Made in Italy.*
- Pure Copper at 99%*
- Pure Tin at 99%*
- All the items are made with Certificated material approved for food contact.*
- The high Thermal conductivity of copper ensures excellent precision in adjusting the temperature.*
- Indispensable for pastry makers.*
- Highest energy savings.*
- Nickel free.*

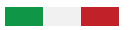

CASSERUOLA ALTA
deep casserole
Cod. 364005..

Ø cm	h cm	Lt	Euro
14	7,5	1,1	52,00
16	9	1,6	58,00
20	15	3,7	156,00
24	15	5,5	186,00



CASSERUOLA BASSA
low casserole
Cod. 364009..

Ø cm	h cm	Lt	Euro
20	9	2,4	134,00
24	10,5	3,7	144,00
30	10	5,5	196,00
36	7,5	7,8	200,00



TEGAME 2 MANIGLIE
roasting pan
Cod. 364023..

Ø cm	h cm	Lt	Euro
18	4,5	0,85	55,00
24	5	1,65	79,00
28	6	2,05	95,00
32	6	3,2	110,00
36	6	3,6	189,00



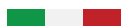

CASSERUOLA 1 MANICO

saucepan

Cod. 364006..

Ø cm	h cm	Lt	Euro
8	5	0,21	31,40
10	6	0,37	34,60
12	6	0,5	37,00
14	7,5	1,1	52,00
16	9	1,6	58,00



PADELLA

frying pan

Cod. 364025..

Ø cm	h cm	Lt	Euro
18	4,5	0,85	56,00
22	4,5	1,0	65,00
24	5	1,65	79,00
26	5,5	1,8	86,00
28	6	2,05	95,00
32	6	3,2	110,00
36	6	3,6	185,00



PAIOLO CON MANICO IN ACCIAIO

cauldron with stainless steel handle

Cod. 36407026

Ø cm	h cm	lt	Euro
26	14	4,5	76,00



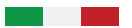

COPERCHIO

lid

Cod. 364035..

Ø cm	Euro
12	19,00
14	24,50
16	29,50
20	35,50
24	41,00
28	55,00
30	57,00
32	66,00
36	90,00



LISTINO RISTAGNATURA

Copper cookware retinning price list

casseroles	Ø cm	Euro
	14	28,00
	16	34,00
	20	44,00
	24	60,00
	30	72,00
	36	84,00

padelle e tegami	Ø cm	Euro
<i>frying pans and</i>	18	24,00
<i>roasting pans</i>	22	25,00
	24	32,00
	26	40,00
	28	45,00
	32	48,00
	36	56,00



PROFESSIONAL 3160

Acciaio Inox 18/10 - Stainless steel 18/10



È la serie BRA nata dalla necessità di dotare la piccola ristorazione, le piccole comunità, gli enti e i residence di una selezione completissima di pezzature, pur mantenendo delle caratteristiche di derivazione professionale.

- Il fondo è realizzato mediante impatto a bilancere
- Il fondo ha una calotta in materiale ferritico adatto all'induzione.
- Le maniglie offrono una presa immediata e sicura
- La finitura satinata con fascia lucida arricchisce i pezzi con un tocco di signorilità
- L'interno è satinato fine per favorire il lavaggio in lavastoviglie
- La forma cilindrica aiuta lo stivaggio dei pezzi.

This series was designed to satisfy the needs of small catering concerns, small communities, organizations and residences with a complete selection of pieces, while maintaining professional features.

- The bottom is made by means of equalizer impact.*
- The bottom has a cover in ferritic material suitable for induction.*
- The handles have a quick and safe grip.*
- The satin finish with a shiny strip gives the pieces a touch of class.*
- The inside is satin finished to make it easy to wash in a dishwasher.*
- The cylindrical shape means easy storage.*

PENTOLA

Pot - Marmite - Suppentopf - Olla
Cod. 316003..

Ø cm	h cm	Lt	Euro
16	12,8	2½	35,74
18	14,4	3½	39,48
20	16	5	47,84
22	17,6	6½	53,40
24	19,2	8½	63,56
26	20,8	10½	73,84
30	22,2	15½	114,38



CASSERUOLA FONDA 2 MANIGLIE

Deep casserole - Casserole avec 2 poignées - Fleischtopf - Cacerola honda 2 mangos
Cod. 316005..

Ø cm	h cm	Lt	Euro
16	8,5	1¾	32,10
18	9,5	2½	35,20
20	10,5	3¼	39,06
22	11,5	4¼	43,12
24	12,5	5½	51,68
26	13,5	7	60,68
30	16	11¼	77,68



CASSERUOLA MEZZA FONDA 2 MANIGLIE

Low casserole - Casserole mi-haute avec 2 poignées - Bratentopf - Cacerola baja 2 mangos
Cod. 316009..

Ø cm	h cm	Lt	Euro
16	7	1¼	32,54
18	7,5	1¾	34,04
20	8	2¼	37,78
22	8,5	3	40,88
24	9	3¾	46,88
26	9,5	4½	55,44
30	10	6½	69,34



TEGAME 2 MANIGLIE

Frying pan 2 handles - Poêle avec 2 poignées - Pfanne mit 2 Griffen - Rustidera 2 mangos
Cod. 316023..

Ø cm	h cm	Lt	Euro
24	5,5	2½	44,08
26	6	3	50,94
30	6,5	4½	65,70



CASSERUOLA FONDA 1 MANICO

Saucepan - Casserole avec 1 manche - Stielkasserolle - Cacerola honda 1 mangos
Cod. 316006..

Ø cm	h cm	Lt	Euro
12	6,5	¾	23,34
14	7,5	1	26,22
16	8,5	1¾	27,50
18	9,5	2½	32,64



BOLLILATTE

Milkpot - Pot à lait - Milchtopf - Pote
Cod. 316060..

Ø cm	h cm	Lt	Euro
12	9,6	1	26,54
14	11,2	1½	30,08



COLAPASTA CESTELLO VAPORE

Colander - Passoire - Sieb mit Griffen - Escurridera
Cod. 316062..

Ø cm	Euro
20	29,44
24	33,50



COLABRODO

Colander - Passoire - Brühesieb - Colador

Cod. 30196914

Ø cm	Euro
14	18,24



PADELLA CON MANICO

Frying pan - Poêle avec manche - Stielpfanne mit Griff - Sarten con mango

Cod. 316025..

Ø cm	Euro
20	25,90
24	30,40
26	34,14
28	42,70



COPERCHIO

Lid - Couvercle - Deckel - Tapa

Cod. 316030..

Ø cm	Euro
16	12,52
18	13,60
20	14,02
22	15,74
24	16,16
26	18,20
30	20,66



COPERCHIO IN VETRO

Glasslid - Couvercle en verre - Glasdeckel - Tapas de cristal

Cod. 971504..

Ø cm	Euro
16	8,68
18	9,10
20	9,64
22	10,38
24	11,14
26	11,78
28	12,40
30	13,70



CUOCIPESCE MONOFONDO

Composto da 3 pezzi:

cuocipesce, coperchio con maniglia, griglia.

Consisting of 3 pcs:

Fishkettle, Lid with handle, Grill.

Composé de 3 pièces:

Poissonnière, Couvercle avec poignée, Grille

Besteht aus 3 Teilen:

Fischkochkessel, Deckel mit Griff, Siebeinsatz.

Compuesto de 3 piezas:

Besuguera, Tapa, Rejilla.

Cod. 308882..

cm	h cm	Lt	Euro
40	10,8	6,00	80,00
50	11,0	8,50	99,00
60	11,0	10,35	118,00







EFFICIENT 3300



-Gamma di prodotti BRA dedicata ai settori del domestico e della ristorazione.

-I prodotti sono stati progettati per offrire la massima robustezza e resistenza alla deformazione grazie sia al materiale utilizzato sia allo studio accurato degli spessori per ciascuno dei punti critici.

-Il rivestimento è in TEFLON PLATINUM by DUPONT: 3 strati di antiaderente (PRIMER, MIDCOAT, PLATINUM) per garantire la massima qualità, durata ed efficienza.

-I prodotti sono rivestiti di antiaderente PLATINUM sia internamente che esternamente per garantire una perfetta pulizia e igiene e la lavabilità in lavastoviglie.

-I coperchi sono realizzati in cristallo antiurto ad elevata resistenza al calore: i pomoli possono essere utilizzati in forno fino alla temperatura massima di 220° C.

-Tutti gli articoli sono adatti all'utilizzo su qualsiasi tipo di piano cottura (compresi vetroceramica e induzione).

-Offre le massime prestazioni sui piani di cottura a induzione e in vetroceramica garantendo una riduzione del 20% per i tempi di cottura e per il consumo energetico rispetto ad altri prodotti esistenti sul mercato.

-La temperatura è uniformemente distribuita in tutta la superficie interna.

-Full range of household and catering products.

-The products have been designed to offer the maximum strength and resistance against deformation thanks both to the material used as well as the in-depth analysis of the thicknesses for each critical point.

TEFLON PLATINUM by DUPONT finish: 3 non-stick coats (PRIMER, MIDCOAT, PLATINUM) to guarantee maximum quality, lifespan and efficiency.

-The products have a PLATINUM non-stick coat both inside and out to guaranty perfect cleaning and hygiene and machine-washable.

-The lids are made of high heat resistant shockproof glass: the knobs can be used in the oven up to a temperature of 220°C.

-All items are suitable for use on any type of cooking surface (including glass-ceramic and induction).

-Offers the maximum performance on induction and glass-ceramic cooking surfaces guaranteeing a reduction of 20% on the cooking time and on the energy consumption in relation to other products on the market.

-Temperature is informally distributed throughout the internal surface.

EFFICIENT

CASSERUOLA FONDA 2 MANIGLIE CON COPERCHIO

Deep Casserole with lid - Casserole avec couvercle - Fleischtopf mit deckel - Cacerola honda con tapa

Cod. 330021..

Ø cm	h cm	Lt	master	Euro
20	9,5	3	4	58,10
24	10,6	4	4	68,60
28	11,0	5,7	4	84,00
32	12,2	8,3	2	99,94
36	13,0	11,2	2	114,18



CASSERUOLA BASSA CON COPERCHIO

Low casserole with lid - Casserole mi-haute avec couverde - Bratentopf mit deckel - Caserola baja con tapa

Cod. 330027..

Ø cm	h cm	Lt	master	Euro
20	5,8	1,5	4	51,36
24	6,1	2,3	4	66,88
28	6,5	3,1	4	74,70
30	7,0	4,1	4	80,46
32	7,7	5	2	88,82
36	8,4	7,1	2	104,12
40	9,1	8	2	114,18



CASSERUOLA BASSA SENZA COPERCHIO

Low casserole without lid - Casserole mi-haute sans couverde - Bratentopf ohne deckel - Caserola baja sin tapa

Cod. 33000945

Ø cm	master	Euro
45	2	135,36



EFFICIENT

PENTOLA CON COPERCHIO

Deep Casserole with lid - Casserole avec couvercle - Fleischtopf mit deckel - Cacerola honda con tapa

Cod. 330117..

Ø cm	h cm	Lt	master	Euro
20	14,6	4,1	4	66,24
24	17,5	6,8	2	83,68
28	20,4	11,1	2	101,98



WOK CON COPERCHIO E GRIGLIA

Wok with lid and grill - Wok avec couverde et grille - Wok mit deckel und grill - Wok con tapa y rejilla

Cod. 330095..

Ø cm	h cm	Lt	master	Euro
24	10,3	3	2	71,70
28	10,6	4,2	2	82,50
32	10,8	5,5	2	96,84



PAELLERA ANTIADERENTE

Casserole/Paellera - Casserole/Paellera - Fleischtopf/Paellera - Cacerola/Paellera honda

Cod. 330039..

Ø cm	h cm	master	Euro
32	4,2	4	81,32
36	4,7	4	89,88
40	5,0	4	106,58



EFFICIENT

PIASTRA ANTIADERENTE

Non-stick hotplate - Plaque antiarèrent - Backblech - Placa antiaderent
Cod. 330029..

cm	master	Euro
35	6	61,36
45	4	72,12



COPPIA PRESINE IN SILICONE

Pair of silicone potholders - paire de mitaines en silicone au four - Paar Silikon
Topflappen - Par de guantes para horno de silicona

Cod.	Mod.	Euro
97150086	casseruola / casserole Ø cm 20	10,20
97150087	casseruola / casserole Ø cm 24-32	11,74
97150088	casseruola / casserole Ø cm 36-45	12,58
97150097	paellera / paellera	11,74
97150098	piastra / hotplate	11,74



CUOCIFORNO ANTIADERENTE CON COPERCHIO

Roasting Pan with lid - Plat à Rôti avec couvercle - Fleischkasten mit deckel -
Rustidera Horno con tapa
Cod. 33007941

cm	h cm	master	Euro
41x29	6,7	4	102,30



EFFICIENT

BACINELLA GN 1/2 ANTIADERENTE

non-stick basin GN 1/2 -bac anti-adhesif GN 1/2

GN-Behälter 1/2 beschichtet -bandeja antiadherente Gn 1/2

Cod. 33008032

cm	master	Euro
32x26	4	58,54



CREPIERE ANTIADERENTE

CON MANICO IN BACHELITE ANTICALORE

Crêpe frying pan with heatproof bakelite handle - Crêpe poêle avec manche en bakélite anti chaleur - Crêpe Bratpfanne mit wärmeschutzgriff - Crêpe sarten con mango de baquelita anticalor

Cod. 33004526

Ø cm	master	Euro
26	6	57,04



CASSERUOLA ANTIADERENTE

CON MANICO IN BACHELITE ANTICALORE

Low casserole with heatproof bakelite handle - Casserole mi-haute avec manche en bakélite anti chaleur - Bratentopf mit wärmeschutzgriff - Caserola con mango de baquelita anticalor

Cod. 33001016

Ø cm	h cm	master	Euro
16	8,2	6	40,98



EFFICIENT

BISTECCHIERA CON MANICO IN BACHELITE ANTICALORE

Gridiron with heatproof bakelite handle - Gril avec manche en bakélite anti chaleur - Grillpfanne mit wärmeschutzgriff - Asador con mango de baquelita anticolor

Cod. 330028..

cm	master	Euro
22	6	43,56
28	6	56,92



BISTECCHIERA CON GRILL E MANICO IN BACHELITE ANTICALORE

Gridiron with heatproof bakelite handle - Gril avec manche en bakélite anti chaleur - Grillpfanne mit wärmeschutzgriff - Asador con mango de baquelita anticolor

Cod. 330053..

cm	master	Euro
22	6	44,62
28	6	57,78



PADELLA CON MANICO IN BACHELITE ANTICALORE

Frying pan with heatproof bakelite handle - Poêle avec manche en bakélite anti chaleur - Bratpfanne mit wärmeschutzgriff - Sarten con mango de baquelita anticolar

Cod. 330025..

Ø cm	master	Euro
16	6	29,96
18	6	32,22
20	6	35,00
22	6	37,14
24	6	40,24
26	6	44,74
28	6	47,08
30	6	55,86





SERIE FORNO

Oven

TEGLIA RETTANGOLARE

Roasting Pan - Plat à Rôti - Fleischkasten - Rustidera Horno

Cod. 548106..

cm	h cm	Euro
25x18	7	34,82
30x21	7	38,94
35x25	7	45,94



COPERCHIO PER TEGLIA

Lid for roasting pan - Couvercle pour plat à rôti - Deckel für Fleischkasten - Tapa para rustidera horno

Cod. 548128..

cm	Euro
25x18	22,04
30x21	25,34
35x25	31,52



TEGLIA PESANTE SPESSORE 2 mm

2 mm thick heavy roasting pan - Plat à rôti, ép. 2 mm -

Fleischkasten extra schwer 2 mm - Rustidera horno esp. 2 mm

Cod. 509004..

cm	h cm	Euro
45x30	9	201,76
50x40	9	244,10
70x45	9	370,46



TEGLIA SATINATA

Satin roasting pan - Plat à rôti satiné - Fleischkasten satiniert - Rustidera horno satinado
Cod. 509003..

cm	h cm	Euro
40x30	8	65,42
50x35	9	77,46
60x40	10	110,52



COPERCHIO SATINATO PER TEGLIA SOVRAPPONIBILE

Satin lid for roasting pan - Couvercle satiné pour plat à rôti -
Deckel satiniert für Fleischkasten - Tapa satinado para rustidera horno
Cod. 509006..

cm	Euro
40x30	45,00
50x35	49,86
60x40	53,46



TORTIERA

Cake plate - Tortière - Backblech - Fuente para tarta
Cod. 509001..

cm	Euro
24x5	21,64
34x6,5	49,30
40x7	60,64



LEGUMIERA OVALE BRA

Oval vegetable dish - Legumier oval - Beilagenschüssel oval - Legumbrera ovalada
Cod. 509046..

cm	h cm	Euro
30x20	3,5	28,68
35x23	4	37,02
40x26	4	42,48
50x32	4,5	60,24



TEGAME UOVO

French omelet pan - Poêle à oeufs - Eierservierschüssel - Paellera huevo
Cod. 50901516

Ø cm	h cm	Euro
16	2	12,98



LUMACHIERA INOX

Snails plate - Plat à escargots - Schneckenplatte - Plato para caracoles
Cod. 509155..

Ø cm	posti	Euro
14	6	6,66
20	12	8,54







G A S T R O N O R M



Per alimenti
Suitable for foodstuffs
Apte au contact avec les aliments
Für Lebensmittel
Apto para alimentos



Garantito per lavastoviglie
Dishwasher safe
Inalterable dans lave-vaisselle
Spelmaschinenfest
Apto para lavavajillas



GASTRONORM



È la rivoluzione in cucina, perché tutte le pezzature sono multipli e sottomultipli tra di loro, permettendo tutte le combinazioni dimensionali richieste dalla ristorazione. La compatibilità con la gamma in policarbonato rende le due serie ancora più performanti nel trasporto, nella presentazione e la conservazione degli alimenti.

This is a kitchen revolution because all the sizes are multiples and submultiples of each other, giving all size combinations as required by the catering industry. Compatibility with the polycarbonate range means the two series perform even better in the transportation, presentation and conservation of food.

BACINELLE SOVRAPPONIBILI

INOX
18/10

Stackable basins

BACINELLA SOVRAPPONIBILE MOD. 2/1

Stackable basin model 2/1 - Bac empilable mod 2/1

Stapelbare schüssel mod 2/1 - Bandeja honda apilable mod. 2/1

IN mm 620x500 OUT mm 650x530

Cod.	h mm	Capacity Lt	Euro
5BA21200	200	58,0	152,46
5BA21150	150	42,8	135,36
5BA21100	100	30,0	96,30
5BA21065	65	18,0	81,38
5BA21040	40	-	69,84
5BA21020	20	-	66,36



BACINELLA SOVRAPPONIBILE MOD. 1/1

Stackable basin model 1/1 - Bac empilable mod 1/1

Stapelbare schüssel mod 1/1 - Bandeja honda apilable mod. 1/1

IN mm 500x295 OUT mm 530x325

Cod.	h mm	Capacity Lt	Euro
5BA11200	200	27,5	85,38
5BA11150	150	20,0	73,20
5BA11100	100	13,7	50,52
5BA11065	65	8,8	38,22
5BA11040	40	-	34,44
5BA11020	20	-	28,98



BACINELLA SOVRAPPONIBILE MOD. 2/3

Stackable basin model 2/3 - Bac empilable mod 2/3

Stapelbare schüssel mod 2/3 - Bandeja honda apilable mod. 2/3

IN mm 330x300 OUT mm 355x325

Cod.	h mm	Capacity Lt	Euro
5BA23200	200	17,0	68,58
5BA23150	150	13,0	58,70
5BA23100	100	9,0	37,08
5BA23065	65	5,8	28,36
5BA23040	40	-	25,00
5BA23020	20	-	21,96



BACINELLA SOVRAPPONIBILE MOD. 1/2

Stackable basin model 1/2 - Bac empilable mod 1/2

Stapelbare schüssel mod 1/2 - Bandeja honda apilable mod. 1/2

IN mm 298x238 OUT mm 325x265

Cod.	h mm	Capacity Lt	Euro
5BA12200	200	12,0	54,50
5BA12150	150	9,2	43,26
5BA12100	100	6,1	28,98
5BA12065	65	4,0	23,22
5BA12040	40	-	20,28
5BA12020	20	-	18,70



BACINELLA SOVRAPPONIBILE MOD. 1/3

Stackable basin model 1/3 - Bac empilable mod 1/3

Stapelbare schüssel mod 1/3 - Bandeja honda apilable mod. 1/3

IN mm 300x150 OUT mm 325x175

Cod.	h mm	Capacity Lt	Euro
5BA13200	200	7,2	45,90
5BA13150	150	5,4	33,72
5BA13100	100	3,5	24,48
5BA13065	65	2,4	20,48



BACINELLA SOVRAPPONIBILE MOD. 1/4

Stackable basin model 1/4 - Bac empilable mod 1/4

Stapelbare schüssel mod 1/4 - Bandeja honda apilable mod. 1/4

IN mm 238x137 OUT mm 264x162

Cod.	h mm	Capacity Lt	Euro
5BA14200	200	4,8	38,00
5BA14150	150	3,8	28,68
5BA14100	100	2,5	21,00
5BA14065	65	1,7	18,80
5BA14040	40	-	17,54
5BA14020	20	-	16,80



BACINELLA SOVRAPPONIBILE MOD. 2/4

Stackable basin model 2/4 - Bac empilable mod 2/4

Stapelbare schüssel mod 2/4 - Bandeja honda apilable mod. 2/4

IN mm 500x136 OUT 530x162 mm

Cod.	h mm	Capacity Lt	Euro
5BA24150	150	8,6	59,00
5BA24100	100	5,8	41,80
5BA24065	65	4,0	30,66
5BA24040	40	-	26,36
5BA24020	20	-	21,84



BACINELLA SOVRAPPONIBILE MOD. 2/8

Stackable basin model 2/8 - Bac empilable mod 2/8

Stapelbare schüssel mod 2/8 - Bandeja honda apilable mod. 2/8

IN mm300x107 OUT mm325x132

Cod.	h mm	Capacity Lt	Euro
5BA28150	150	3,9	35,70
5BA28100	100	2,6	27,72
5BA28065	65	1,7	21,54
5BA28040	40	-	19,22
5BA28020	20	-	17,22



BACINELLA SOVRAPPONIBILE MOD. 1/6

Stackable basin model 1/6 - Bac empilable mod 1/6

Stapelbare schüssel mod 1/6 - Bandeja honda apilable mod. 1/6

IN mm153x140 OUT mm 176x162

Cod.	h mm	Capacity Lt	Euro
5BA16200	200	3,5	47,46
5BA16150	150	2,3	28,88
5BA16100	100	1,5	18,18
5BA16065	65	1,0	15,24
5BA16040	40	-	14,18
5BA16020	20	-	11,34



BACINELLA SOVRAPPONIBILE MOD. 1/9

Stackable basin model 1/9 - Bac empilable mod 1/9

Stapelbare schüssel mod 1/9 - Bandeja honda apilable mod. 1/9

IN mm 150x93 OUT mm 176x108

Cod.	h mm	Capacity Lt	Euro
5BA19100	100	0,8	20,38
5BA19065	65	0,6	15,44



BACINELLE - TEGLIE

Alluminio con bordo - Interno teflonato

TEGLIA ALLUMINIO CON BORDO. INTERNO TEFLONATO MOD. 1/1

Non-stick aluminium basin, with edge model 1/1

Bac antiadhérent en alu, avec bord mod 1/1

Backform aus alum., antihftbeschichtet mod 1/1

Rustidera alum. con borde, interior teflon mod. 1/1

IN mm 500x295 OUT mm 530x325

Cod.	h mm	Capacity Lt	Euro
5TAT1102	20	-	53,24
5TAT1104	40	-	60,28
5TAT1165	65	8,8	70,14



TEGLIA ALLUMINIO CON BORDO. INTERNO TEFLONATO MOD. 2/3

Non-stick aluminium basin, with edge model 2/3

Bac antiadhérent en alu, avec bord mod 2/3

Backform aus alum., antihftbeschichtet mod 2/3

Rustidera alum. con borde, interior teflon mod. 2/3

IN mm 330x300 OUT mm 355x325

Cod.	h mm	Capacity Lt	Euro
5TAT2302	20	-	37,70
5TAT2304	40	-	41,38
5TAT2365	65	5,8	49,46



TEGLIA ALLUMINIO CON BORDO. INTERNO TEFLONATO MOD. 1/2

Non-stick aluminium basin, with edge model 1/2

Bac antiadhérent en alu, avec bord mod 1/2

Backform aus alum., antihftbeschichtet mod 1/2

Rustidera alum. con borde, interior teflon mod. 1/2

IN mm 330x300 OUT mm 355x325

Cod.	h mm	Capacity Lt	Euro
5TAT1202	20	-	31,62
5TAT1204	40	-	34,66
5TAT1265	65	4,0	40,32



BACINELLE FORATE SOVRAPPONIBILI

INOX
18/10

Perforated stackable basins

BACINELLA FORATA MOD. 2/1

Perforated stackable basin model 2/1 - Bac perforé empilable mod 2/1

Stapelbare Schüssel mit Löchern mod 2/1 - Bandeja honda perforada apilable mod. 2/1

IN mm 620x500 OUT mm 650x530

Cod.	h mm	Capacity Lt	Euro
5BF21200	200	58,0	285,36
5BF21150	150	42,8	236,20
5BF21100	100	30,0	164,86
5BF21065	65	18,0	116,88
5BF21040	40	-	105,62
5BF21020	20	-	102,90



BACINELLA FORATA MOD. 1/1

Perforated stackable basin model 1/1 - Bac perforé empilable mod 1/1

Stapelbare Schüssel mit Löchern mod 1/1 - Bandeja honda perforada apilable mod. 1/1

IN mm 500x295 OUT mm 530x325

Cod.	h mm	Capacity Lt	Euro
5BF11200	200	27,8	154,36
5BF11150	150	20,0	125,70
5BF11100	100	13,7	78,86
5BF11065	65	8,8	54,40
5BF11040	40	-	43,90
5BF11020	20	-	38,54



BACINELLA FORATA MOD. 2/3

Perforated stackable basin model 2/3 - Bac perforé empilable mod 2/3

Stapelbare Schüssel mit Löchern mod 2/3 - Bandeja honda perforada apilable mod. 2/3

IN mm 330x300 OUT mm 355x325

Cod.	h mm	Capacity Lt	Euro
5BF23200	200	17,0	110,62
5BF23150	150	13,0	91,70
5BF23100	100	9,0	61,00
5BF23065	65	5,8	34,98
5BF23040	40	-	30,98
5BF23020	20	-	29,20



BACINELLA FORATA MOD. 1/2

Perforated stackable basin model 1/2 - Bac perforé empilable mod 1/2

Stapelbare Schüssel mit Löchern mod 1/2 - Bandeja honda perforada apilable mod. 1/2

IN mm 298x238 OUT mm 325x265

Cod.	h mm	Capacity Lt	Euro
5BF12200	200	12,0	90,52
5BF12150	150	9,2	73,40
5BF12100	100	6,1	47,04
5BF12065	65	4,0	30,98
5BF12040	40	-	27,72
5BF12020	20	-	26,46



BACINELLA FORATA MOD. 1/3

Perforated stackable basin model 1/3 - Bac perforé empilable mod 1/3

Stapelbare Schüssel mit Löchern mod 1/3 - Bandeja honda perforada apilable mod. 1/3

IN mm 300x150 OUT mm 325x175

Cod.	h mm	Capacity Lt	Euro
5BF13200	200	7,2	75,24
5BF13150	150	5,4	53,56
5BF13100	100	3,5	40,00
5BF13065	65	2,4	24,78



BACINELLA FORATA INCASSO MOD. 1/1

Perforated insertable basin model 1/1 - Bac perforé à encastrement mod 1/1

Schüssel mit Löchern, versenkt mod 1/1 - Bandeja honda perforada de Encastrar mod. 1/1

IN mm 500x295 OUT mm 530x325

Cod.	h mm	Capacity Lt	Euro
5BI11090	90	10,6	78,76
5BI11055	55	6,5	50,30

foto dimostrativa
sample photo

TEGLIE

INOX
18/10

Trays

TEGLIA MOD. 2/1 BORDO PIANO

Tray 2/1 flat edge - Bac à four 2/1 bord plat

Fleischkasten 2/1 mit flachem Rand - Rustidera horno 2/1 bordo llana

IN mm 620x500 OUT mm 650x530

Cod.	h mm	Capacity Lt	Euro
5TI21065	65	18,0	81,38
5TI21040	40	11,2	69,84
5TI21020	20	5,6	66,36



TEGLIA MOD. 1/1 BORDO PIANO

Tray 1/1 flat edge - Bac à four 1/1 bord plat

Fleischkasten 1/1 mit flachem Rand - Rustidera horno 1/1 bordo llana

IN mm 500x295 OUT mm 530x325

Cod.	h mm	Capacity Lt	Euro
5TI11065	65	8,8	38,22
5TI11040	40	5,3	34,34
5TI11020	20	2,6	28,98



TEGLIA MOD. 2/3 BORDO PIANO

Tray 2/3 flat edge - Bac à four 2/3 bord plat

Fleischkasten 2/3 mit flachem Rand - Rustidera horno 2/3 bordo llana

IN mm 300x300 OUT mm 355x325

Cod.	h mm	Capacity Lt	Euro
5TI23065	65	5,8	28,36
5TI23040	40	3,7	25,00
5TI23020	20	1,7	21,96



TEGLIA MOD. 1/2 BORDO PIANO

Tray 1/2 flat edge - Bac à four 1/2 bord plat

Fleischkasten 1/2 mit flachem Rand - Rustidera horno 1/2 bordo llana

IN mm 298x238 OUT mm 325x265

Cod.	h mm	Capacity Lt	Euro
5TI12065	65	4,0	23,64
5TI12040	40	2,4	20,48
5TI12020	20	1,2	19,12



BACINELLE

Basins

BACINELLA CON MANIGLIE RIENTRANTI

Basin with retractable handles - Bac avec anses rentrantes

Schüssel mit Fallgriffen - Bandeja honda con mangos entrantes

Cod.	mod.	IN mm	OUT mm	h mm	Capacity Lt	Euro
5BR11200	1/1			200	27,8	94,72
5BR11150	1/1	500x295	530x325	150	20,0	82,54
5BR11100	1/1			100	13,7	59,80

Cod.	mod.	IN mm	OUT mm	h mm	Capacity Lt	Euro
5BR23200	2/3			200	17,0	77,92
5BR23150	2/3	330x300	355x325	150	13,0	67,98
5BR23100	2/3			100	9,0	46,50

Cod.	mod.	IN mm	OUT mm	h mm	Capacity Lt	Euro
5BR12200	1/2			200	12,0	63,74
5BR12150	1/2	298x238	325x265	150	9,2	52,62
5BR12100	1/2			100	6,1	32,46

Cod.	mod.	IN mm	OUT mm	h mm	Capacity Lt	Euro
5BR13200	1/3			200	7,2	55,16
5BR13150	1/3	300x150	325x175	150	5,4	43,24
5BR13100	1/3			100	3,5	33,76

Cod.	mod.	IN mm	OUT mm	h mm	Capacity Lt	Euro
5BR14200	1/4			200	4,8	47,30
5BR14150	1/4	238x137	264x162	150	3,8	38,32
5BR14100	1/4			100	2,5	30,38



particolare
maniglie rientranti
*detail of
retractable handles*

Lids

COPERCHIO NORMALE

Normal lid - Couvercle - Normaler Deckel - Tapa

Cod.	mod.	Euro
5CO11000	1/1	32,76
5CO23000	2/3	22,68
5CO12000	1/2	19,44
5CO13000	1/3	15,24
5CO14000	1/4	12,72
5CO24000	2/4	26,42
5CO28000	2/8	11,56
5CO16000	1/6	10,92
5CO19000	1/9	7,88



COPERCHIO NORMALE CON SPACCO PER MESTOLO

Normal lid with ladle slot - Couvercle avec fente pour louche

Normaler Deckel mit Schlitz für Suppenschöpfer - Tapa con hendidura para cazo

Cod.	mod.	Euro
5CSME110	1/1	36,24
5CSME230	2/3	26,26
5CSME120	1/2	23,10
5CSME130	1/3	18,80
5CSME140	1/4	16,46
5CSME160	1/6	14,80



COPERCHIO NORMALE CON SPACCO PER MANIGLIE

Normal lid with handle slot - Couvercle avec fente pour anses

Normaler Deckel mit Schlitz für Griffen - Tapa con hendidura para mangos

Cod.	mod.	Euro
5CSMA110	1/1	36,24
5CSMA230	2/3	26,26
5CSMA120	1/2	23,10
5CSMA130	1/3	18,80
5CSMA140	1/4	16,46
5CSMA160	1/6	14,80



COPERCHIO NORMALE CON SPACCO PER MESTOLO E MANIGLIE

Normal Lid with ladle and handle slot

Couvercle avec fente pour louche et anses

Normaler Deckel mit Schlitz für Griffen und Suppenschöpfer

Tapa con hendidura para cazo y mangos

Cod.	mod.	Euro
5CSMM110	1/1	39,70
5CSMM230	2/3	29,82
5CSMM120	1/2	27,10
5CSMM130	1/3	23,00
5CSMM140	1/4	20,48
5CSMM160	1/6	19,22



COPERCHIO A TENUTA CON GUARNIZIONE AL SILICONE

Sealing lid with silicone gasket - Couvercle à etanche avec garniture

Deckel mit Silikondichtung - Tapa estanca con junta s

Cod.	mod.	Euro
5CT11000	1/1	106,06
5CT23000	2/3	78,22
5CT12000	1/2	75,40
5CT13000	1/3	64,26
5CT14000	1/4	51,46
5CT16000	1/6	44,10



COPERCHIO A TENUTA CON SPACCO PER MANIGLIE

Sealing lid with handle slot - Couvercle à etanche, avec fente

Deckel mit Schlitz für Griffen - Tapa estanca con hendidura para mangos

Cod.	mod.	Euro
5CTSM110	1/1	110,26
5CTSM230	2/3	81,90
5CTSM120	1/2	79,00
5CTSM130	1/3	67,84
5CTSM140	1/4	55,12



FALSI FONDI-SEPARATORI- VASSOI A SCOMPRTO

INOX
18/10

FALSO FONDO FORATO

False perforated bottom - Faux-fond perforé - Falscher Boden mit Löchern - Falso hondo perforado

Cod.	mod.	Euro
5FF11000	1/1	42,54
5FF23000	2/3	32,46
5FF12000	1/2	28,04
5FF21000	2/1	68,46



SEPARATORE

Divider - Séparateur - Teiler - Separador

Cod.	mm	Euro
5SE11000	530	5,16
5SE12000	325	3,48



VASSOIO 4 SCOMPARTI BORDO PIANO SENZA PIEDINI

Tray with 4 sectors, flat edge without feet - Plateau 4 secteurs, bord plat
Tablett mit 4 Sektoren und flachem Rand ohne Füße - Bandeja 4 secciones, bordo llano, sin pies

Cod.	mm	Euro
5VS4BPSP	400x300	36,76



VASSOIO 5 SCOMPARTI BORDO PIANO SENZA PIEDINI

Tray with 5 sectors, flat edge without feet - Plateau 5 secteurs, bord plat
Tablett mit 5 Sektoren und flachem Rand ohne Füße - Bandeja 5 secciones, bordo llano, sin pies

Cod.	mm	h mm	Euro
5VS5BPSP	400x350	20	39,80



POLICARBONATO

Polycarbonate

BACINELLA SOVRAPPONIBILE MOD. 1/1

Stackable basin model 1/1 - Bac empilable mod 1/1

Stapelbare schüssel mod 1/1 - Bandeja honda apilable mod. 1/1

Cod.	h mm	Euro
5BP11200	200	38,86
5BP11150	150	30,14
5BP11100	100	23,84
5BP11065	65	20,90



BACINELLA SOVRAPPONIBILE MOD. 1/2

Stackable basin model 1/2 - Bac empilable mod 1/2

Stapelbare schüssel mod 1/2 - Bandeja honda apilable mod. 1/2

Cod.	h mm	Euro
5BP12200	200	20,90
5BP12150	150	17,76
5BP12100	100	14,08
5BP12065	65	12,30



BACINELLA SOVRAPPONIBILE MOD. 1/3

Stackable basin model 1/3 - Bac empilable mod 1/3

Stapelbare schüssel mod 1/3 - Bandeja honda apilable mod. 1/3

Cod.	h mm	Euro
5BP13200	200	17,54
5BP13150	150	14,40
5BP13100	100	11,56
5BP13065	65	10,22



POLICARBONATO

BACINELLA SOVRAPPONIBILE MOD. 1/4

Stackable basin model 1/4 - Bac empilable mod 1/4

Stapelbare schüssel mod 1/4 - Bandeja honda apilable mod. 1/4

Cod.	h mm	Euro
5BP14200	200	16,84
5BP14150	150	14,18
5BP14100	100	10,56
5BP14065	65	8,88



BACINELLA SOVRAPPONIBILE MOD. 1/6

Stackable basin model 1/6 - Bac empilable mod 1/6

Stapelbare schüssel mod 1/6 - Bandeja honda apilable mod. 1/6

Cod.	h mm	Euro
5BP16200	200	12,54
5BP16150	150	8,40
5BP16100	100	7,04
5BP16065	65	6,12



BACINELLA SOVRAPPONIBILE MOD. 1/9

Stackable basin model 1/9 - Bac empilable mod 1/9

Stapelbare schüssel mod 1/9 - Bandeja honda apilable mod. 1/9

Cod.	h mm	Euro
5BP19100	100	4,96
5BP19065	65	5,92



POLICARBONATO

BACINELLA SOVRAPPONIBILE MOD. 2/1

Stackable basin model 2/1 - Bac empilable mod 2/1

Stapelbare schüssel mod 2/1 - Bandeja honda apilable mod. 2/1

Cod.	h mm	Euro
5BP21200	200	77,98



COPERCHIO

Lid - Couvercle - Deckel - Tapa

Cod.	mod.	Euro
5CP21000	2/1	37,60
5CP11000	1/1	15,54
5CP12000	1/2	12,30
5CP13000	1/3	7,56
5CP14000	1/4	6,76
5CP16000	1/6	4,42
5CP19000	1/9	3,86



FALSO FONDO FORATO

False perforated bottom - Faux-fond perforé - Falscher Boden mit Löchern -

Falso hondo perforado

Cod.	mod.	Euro
5FP21000	2/1	38,44
5FP11000	1/1	9,66
5FP12000	1/2	5,88





TENDER GASTRONORM

**Vendita solo a Master
Only master selling**

Made in Italy 

La serie Gastronorm Tender è caratterizzata da un ottimo rapporto qualità/prezzo. Le caratteristiche principali sono le seguenti:

- Produzione totalmente italiana.
- Tutti i materiali impiegati sono della migliore qualità e idonei al contatto alimentare ai sensi del DM 25/01/1992 art. 4 – 5° comma e della DIR. CEE 89/109.
- Tutte le misure più grandi sono normalizzate a garanzia di una maggiore resistenza dell'articolo.
- Massima capienza nel minimo ingombro grazie all'ottimizzazione delle raggature.
- Bordi smerigliati per una maggior sicurezza nell'utilizzo.
- Ogni articolo confezionato in busta trasparente.

Gastronorm new TENDER series is a perfect combination of price and quality. Main Technical characteristics

- All the series are Made in Italy.
- All the material used in mass production are suitable for food contacts as for the law DM 25/01/1992 art. 4 – 5° comma and DIR. CEE 89/109.
- All the big sizes are done with special operation for improving resistance.
- Sizes are done to reduce as much as possible the volume, they are stackable.
- Borders are done to avoid any personal damages during use.
- Every piece is in a transparent polybag.

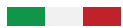

BACINELLE SOVRAPPONIBILI

Stackable basins

BACINELLA SOVRAPPONIBILE MOD. 2/1

Stackable basin model 2/1 - Bac empilable mod 2/1

Stapelbare schüssel mod 2/1 - Bandeja honda apilable mod. 2/1

IN mm 620x500 OUT mm 650x530

Cod.	h mm	Capacity Lt	master	Euro master
7BA21200	200	58,0	1	108,48
7BA21150	150	42,8	1	96,30
7BA21100	100	30,0	1	68,16
7BA21065	65	18,0	1	57,76
7BA21040	40	-	1	49,46
7BA21020	20	-	1	46,94



BACINELLA SOVRAPPONIBILE MOD. 1/1

Stackable basin model 1/1 - Bac empilable mod 1/1

Stapelbare schüssel mod 1/1 - Bandeja honda apilable mod. 1/1

IN mm 500x295 OUT mm 530x325

Cod.	h mm	Capacity Lt	(Euro pcs)	master	Euro master
7BA11200	200	27,5	59,24	6	355,44
7BA11150	150	20,0	51,66	6	309,96
7BA11100	100	13,7	32,87	6	197,20
7BA11065	65	8,8	24,87	6	149,22
7BA11040	40	-	22,50	12	270,04
7BA11020	20	-	21,04	12	252,48



BACINELLA SOVRAPPONIBILE MOD. 2/3

Stackable basin model 2/3 - Bac empilable mod 2/3

Stapelbare schüssel mod 2/3 - Bandeja honda apilable mod. 2/3

IN mm 330x300 OUT mm 355x325

Cod.	h mm	Capacity Lt	(Euro pcs)	master	Euro master
7BA23200	200	17,0	49,92	6	299,52
7BA23150	150	13,0	41,89	12	502,64
7BA23100	100	9,0	26,78	6	160,66
7BA23065	65	5,8	18,50	6	111,00
7BA23040	40	-	16,43	12	197,20
7BA23020	20	-	15,95	24	382,74



BACINELLE SOVRAPPONIBILI

**INOX
18/10**

SOLO
VENDITA
MASTER
ONLY
MASTER
SELLING



BACINELLA SOVRAPPONIBILE MOD. 1/2

Stackable basin model 1/2 - Bac empilable mod 1/2

Stapelbare schüssel mod 1/2 - Bandeja honda apilable mod. 1/2

IN mm 298x238 OUT mm 325x265

Cod.	h mm	Capacity Lt	(Euro pcs)	master	Euro master
7BA12200	200	12,0	38,80	12	465,58
7BA12150	150	9,2	32,60	12	391,18
7BA12100	100	6,1	19,14	12	229,68
7BA12065	65	4,0	15,36	12	184,28
7BA12040	40	-	13,24	12	158,88
7BA12020	20	-	12,11	24	290,64



BACINELLA SOVRAPPONIBILE MOD. 1/3

Stackable basin model 1/3 - Bac empilable mod 1/3

Stapelbare schüssel mod 1/3 - Bandeja honda apilable mod. 1/3

IN mm 300x150 OUT mm 325x175

Cod.	h mm	Capacity Lt	(Euro pcs)	master	Euro master
7BA13200	200	7,2	33,50	12	401,94
7BA13150	150	5,4	24,57	12	294,84
7BA13100	100	3,5	16,13	12	193,52
7BA13065	65	2,4	13,39	12	160,66



BACINELLA SOVRAPPONIBILE MOD. 1/4

Stackable basin model 1/4 - Bac empilable mod 1/4

Stapelbare schüssel mod 1/4 - Bandeja honda apilable mod. 1/4

IN mm 238x137 OUT mm 264x162

Cod.	h mm	Capacity Lt	(Euro pcs)	master	Euro master
7BA14200	200	4,8	27,76	12	333,06
7BA14150	150	3,8	20,89	12	250,68
7BA14100	100	2,5	13,73	12	164,70
7BA14065	65	1,7	11,48	12	137,72
7BA14040	40	-	10,69	12	128,28
7BA14020	20	-	10,54	24	252,90



BACINELLA SOVRAPPONIBILE MOD. 2/4

Stackable basin model 2/4 - Bac empilable mod 2/4

Stapelbare schüssel mod 2/4 - Bandeja honda apilable mod. 2/4

IN mm 500x136 OUT 530x162 mm

Cod.	h mm	Capacity Lt	(Euro pcs)	master	Euro master
7BA24150	150	8,6	43,05	12	516,60
7BA24100	100	5,8	30,45	12	365,40
7BA24065	65	4,0	21,89	12	262,62
7BA24040	40	-	19,13	24	459,08
7BA24020	20	-	15,92	24	382,10



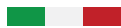

BACINELLE SOVRAPPONIBILI

BACINELLA SOVRAPPONIBILE MOD. 2/8

Stackable basin model 2/8 - Bac empilable mod 2/8

Stapelbare schüssel mod 2/8 - Bandeja honda apilable mod. 2/8

IN mm300x107 OUT mm325x132

Cod.	h mm	Capacity Lt	(Euro pcs)	master	Euro master
7BA28150	150	3,9	26,00	12	311,96
7BA28100	100	2,6	20,19	12	242,24
7BA28065	65	1,7	14,61	12	175,26
7BA28040	40	-	13,07	12	156,82
7BA28020	20	-	11,25	24	269,96



BACINELLA SOVRAPPONIBILE MOD. 1/6

Stackable basin model 1/6 - Bac empilable mod 1/6

Stapelbare schüssel mod 1/6 - Bandeja honda apilable mod. 1/6

IN mm153x140 OUT mm 176x162

Cod.	h mm	Capacity Lt	(Euro pcs)	master	Euro master
7BA16200	200	3,5	34,77	12	417,28
7BA16150	150	2,3	21,23	12	254,74
7BA16100	100	1,5	11,97	12	143,58
7BA16065	65	1,0	9,90	12	118,76
7BA16040	40	-	9,42	24	225,96
7BA16020	20	-	8,47	24	203,32



BACINELLA SOVRAPPONIBILE MOD. 1/9

Stackable basin model 1/9 - Bac empilable mod 1/9

Stapelbare schüssel mod 1/9 - Bandeja honda apilable mod. 1/9

IN mm 150x93 OUT mm 176x108

Cod.	h mm	Capacity Lt	(Euro pcs)	master	Euro master
7BA19100	100	0,8	15,15	24	363,62
7BA19065	65	0,6	9,56	24	229,54



BACINELLE FORATE SOVRAPPONIBILI

INOX
18/10

S O L O
VENDITA
MASTER
O N L Y
MASTER
SELLING



Perforated stackable basins

BACINELLA FORATA MOD. 2/1

Perforated stackable basin model 2/1 - Bac perforé empilable mod 2/1

Stapelbare Schüssel mit Löchern mod 2/1 - Bandeja honda perforada apilable mod. 2/1

IN mm 620x500 OUT mm 650x530

Cod.	h mm	Capacity Lt	master	Euro master
7BF21200	200	58,0	1	181,56
7BF21150	150	42,8	1	151,94
7BF21100	100	30,0	1	105,84
7BF21065	65	18,0	1	77,50
7BF21040	40	-	1	69,62
7BF21020	20	-	1	67,74



BACINELLA FORATA MOD. 1/1

Perforated stackable basin model 1/1 - Bac perforé empilable mod 1/1

Stapelbare Schüssel mit Löchern mod 1/1 - Bandeja honda perforada apilable mod. 1/1

IN mm 500x295 OUT mm 530x325

Cod.	h mm	Capacity Lt	(Euro pcs)	master	Euro master
7BF11200	200	27,8	96,13	6	576,78
7BF11150	150	20,0	80,68	6	484,06
7BF11100	100	13,7	52,68	6	316,06
7BF11065	65	8,8	32,22	6	193,32
7BF11040	40	-	29,52	12	354,28
7BF11020	20	-	26,79	12	321,42



BACINELLA FORATA MOD. 2/3

Perforated stackable basin model 2/3 - Bac perforé empilable mod 2/3

Stapelbare Schüssel mit Löchern mod 2/3 - Bandeja honda perforada apilable mod. 2/3

IN mm 330x300 OUT mm 355x325

Cod.	h mm	Capacity Lt	(Euro pcs)	master	Euro master
7BF23200	200	17,0	73,08	6	438,48
7BF23150	150	13,0	59,79	12	717,48
7BF23100	100	9,0	39,90	6	239,40
7BF23065	65	5,8	21,86	6	131,16
7BF23040	40	-	20,00	12	240,04
7BF23020	20	-	20,21	24	485,00



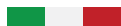

BACINELLA FORATA MOD. 1/2

Perforated stackable basin model 1/2 - Bac perforé empilable mod 1/2

Stapelbare Schüssel mit Löchern mod 1/2 - Bandeja honda perforada apilable mod. 1/2

IN mm 298x238 OUT mm 325x265

Cod.	h mm	Capacity Lt	(Euro pcs)	master	Euro master
7BF12200	200	12,0	58,62	12	703,40
7BF12150	150	9,2	48,65	12	583,80
7BF12100	100	6,1	30,94	12	371,28
7BF12065	65	4,0	19,95	12	239,40
7BF12040	40	-	18,19	12	218,28
7BF12020	20	-	16,43	24	394,28



BACINELLA FORATA MOD. 1/3

Perforated stackable basin model 1/3 - Bac perforé empilable mod 1/3

Stapelbare Schüssel mit Löchern mod 1/3 - Bandeja honda perforada apilable mod. 1/3

IN mm 300x150 OUT mm 325x175

Cod.	h mm	Capacity Lt	(Euro pcs)	master	Euro master
7BF13200	200	7,2	48,29	12	579,50
7BF13150	150	5,4	34,53	12	414,34
7BF13100	100	3,5	24,20	12	290,44
7BF13065	65	2,4	14,53	12	174,30



TEGLIE

Trays

INOX
18/10

SOLO
VENDITA
MASTER
ONLY
MASTER
SELLING



TEGLIA MOD. 2/1 BORDO PIANO

Tray 2/1 flat edge - Bac à four 2/1 bord plat

Fleischkasten 2/1 mit flachem Rand - Rustidera horno 2/1 bordo llana

IN mm 620x500 OUT mm 650x530

Cod.	h mm	Capacity Lt	master	Euro master
7TI21065	65	18,0	1	57,76
7TI21040	40	11,2	1	49,46
7TI21020	20	5,6	1	46,94



TEGLIA MOD. 1/1 BORDO PIANO

Tray 1/1 flat edge - Bac à four 1/1 bord plat

Fleischkasten 1/1 mit flachem Rand - Rustidera horno 1/1 bordo llana

IN mm 500x295 OUT mm 530x325

Cod.	h mm	Capacity Lt	(Euro pcs)	master	Euro master
7TI11065	65	8,8	24,87	6	149,22
7TI11040	40	5,3	22,51	12	270,06
7TI11020	20	2,6	21,05	12	252,54



TEGLIA MOD. 2/3 BORDO PIANO

Tray 2/3 flat edge - Bac à four 2/3 bord plat

Fleischkasten 2/3 mit flachem Rand - Rustidera horno 2/3 bordo llana

IN mm 300x300 OUT mm 355x325

Cod.	h mm	Capacity Lt	(Euro pcs)	master	Euro master
7TI23065	65	5,8	18,50	6	111,00
7TI23040	40	3,7	16,43	12	197,20
7TI23020	20	1,7	15,95	24	382,74



TEGLIA MOD. 1/2 BORDO PIANO

Tray 1/2 flat edge - Bac à four 1/2 bord plat

Fleischkasten 1/2 mit flachem Rand - Rustidera horno 1/2 bordo llana

IN mm 298x238 OUT mm 325x265

Cod.	h mm	Capacity Lt	(Euro pcs)	master	Euro master
7TI12065	65	4,0	15,36	12	184,28
7TI12040	40	2,4	13,24	12	158,88
7TI12020	20	1,2	12,12	24	290,76



COPERCHI

Lids

COPERCHIO NORMALE

Normal lid - Couvercle - Normaler Deckel - Tapa

Cod.	mod.	(Euro pcs)	master	Euro master
7CO11000	1/1	23,78	12	285,40
7CO23000	2/3	16,43	12	197,20
7CO12000	1/2	14,04	12	168,42
7CO13000	1/3	11,18	12	134,20
7CO14000	1/4	9,42	12	112,98
7CO24000	2/4	16,13	12	193,52
7CO28000	2/8	8,63	12	103,54
7CO16000	1/6	7,99	12	95,88
7CO19000	1/9	5,75	24	137,88



FALSO FONDO

False bottom

FALSO FONDO FORATO

False perforated bottom - Faux-fond perforé - Falscher Boden mit Löchern - Falso hondo perforado

Cod.	mod.	(Euro pcs)	master	Euro master
7FF11000	1/1	24,87	24	596,94
7FF23000	2/3	19,13	24	459,18
7FF12000	1/2	16,43	24	394,38
7FF21000	2/1	42,64	1	42,64



POLICARBONATO

Polycarbonate

INOX
18/10

S O L O
VENDITA
MASTER
O N L Y
MASTER
SELLING



BACINELLA SOVRAPPONIBILE MOD. 1/1

Stackable basin model 1/1 - Bac empilable mod 1/1

Stapelbare schüssel mod 1/1 - Bandeja honda apilable mod. 1/1

Cod.	h mm	(Euro pcs)	master	Euro master
7BP11200	200	28,61	6	171,68
7BP11150	150	23,15	6	138,92
7BP11100	100	18,68	6	112,08
7BP11065	65	16,43	6	98,60



BACINELLA SOVRAPPONIBILE MOD. 1/2

Stackable basin model 1/2 - Bac empilable mod 1/2

Stapelbare schüssel mod 1/2 - Bandeja honda apilable mod. 1/2

Cod.	h mm	(Euro pcs)	master	Euro master
7BP12200	200	15,18	12	182,18
7BP12150	150	13,24	12	158,88
7BP12100	100	10,39	12	124,64
7BP12065	65	8,66	12	103,96



BACINELLA SOVRAPPONIBILE MOD. 1/3

Stackable basin model 1/3 - Bac empilable mod 1/3

Stapelbare schüssel mod 1/3 - Bandeja honda apilable mod. 1/3

Cod.	h mm	(Euro pcs)	master	Euro master
7BP13200	200	12,95	12	155,40
7BP13150	150	10,55	12	126,54
7BP13100	100	8,30	12	99,54
7BP13065	65	7,72	12	92,62



POLICARBONATO

BACINELLA SOVRAPPONIBILE MOD. 1/4

Stackable basin model 1/4 - Bac empilable mod 1/4

Stapelbare schüssel mod 1/4 - Bandeja honda apilable mod. 1/4

Cod.	h mm	(Euro pcs)	master	Euro master
7BP14200	200	12,72	12	152,68
7BP14150	150	10,71	12	128,52
7BP14100	100	7,96	12	95,56
7BP14065	65	6,71	12	80,54



BACINELLA SOVRAPPONIBILE MOD. 1/6

Stackable basin model 1/6 - Bac empilable mod 1/6

Stapelbare schüssel mod 1/6 - Bandeja honda apilable mod. 1/6

Cod.	h mm	(Euro pcs)	master	Euro master
7BP16200	200	9,47	12	113,62
7BP16150	150	6,71	12	80,54
7BP16100	100	4,95	12	59,44
7BP16065	65	4,61	12	55,34



BACINELLA SOVRAPPONIBILE MOD. 1/9

Stackable basin model 1/9 - Bac empilable mod 1/9

Stapelbare schüssel mod 1/9 - Bandeja honda apilable mod. 1/9

Cod.	h mm	(Euro pcs)	master	Euro master
7BP19100	100	4,47	24	107,42
7BP19065	65	3,75	24	89,88



BACINELLA SOVRAPPONIBILE MOD. 2/1

Stackable basin model 2/1 - Bac empilable mod 2/1

Stapelbare schüssel mod 2/1 - Bandeja honda apilable mod. 2/1

Cod.	h mm	master	Euro master
7BP21200	200	1	59,12



COPERCHIO

Lid - Couvercle - Deckel - Tapa

Cod.	mod.	(Euro pcs)	master	Euro master
7CP21000	2/1	34,30	6	205,80
7CP11000	1/1	13,08	12	156,98
7CP12000	1/2	7,35	12	88,20
7CP13000	1/3	5,44	12	65,32
7CP14000	1/4	5,01	24	120,24
7CP16000	1/6	3,30	24	79,28
7CP19000	1/9	2,86	24	68,68



FALSO FONDO FORATO

False perforated bottom - Faux-fond perforé - Falscher Boden mit Löchern -

Falso hondo perforado

Cod.	mod.	(Euro pcs)	master	Euro master
7FP21000	2/1	23,44	12	281,30
7FP11000	1/1	8,14	24	195,30
7FP12000	1/2	4,95	24	118,76



POLIPROPILENE

Polypropylene

BACINELLA SOVRAPPONIBILE MOD. 1/1

Stackable basin model 1/1 - Bac empilable mod 1/1

Stapelbare schüssel mod 1/1 - Bandeja honda apilable mod. 1/1

Cod.	h mm	(Euro pcs)	master	Euro master
7PP11200	200	16,59	6	99,54
7PP11150	150	13,41	6	80,44
7PP11100	100	11,03	6	66,16
7PP11065	65	10,63	12	127,58



BACINELLA SOVRAPPONIBILE MOD. 1/2

Stackable basin model 1/2 - Bac empilable mod 1/2

Stapelbare schüssel mod 1/2 - Bandeja honda apilable mod. 1/2

Cod.	h mm	(Euro pcs)	master	Euro master
7PP12200	200	8,75	12	105,00
7PP12150	150	7,66	12	91,88
7PP12100	100	6,23	12	74,76
7PP12065	65	5,75	12	68,98



BACINELLA SOVRAPPONIBILE MOD. 1/3

Stackable basin model 1/3 - Bac empilable mod 1/3

Stapelbare schüssel mod 1/3 - Bandeja honda apilable mod. 1/3

Cod.	h mm	(Euro pcs)	master	Euro master
7PP13200	200	7,51	12	90,10
7PP13150	150	6,23	12	74,76
7PP13100	100	5,11	24	122,64
7PP13065	65	5,06	24	121,38



POLIPROPILENE

S O L O
VENDITA
MASTER
O N L Y
MASTER
SELLING

BACINELLA SOVRAPPONIBILE MOD. 1/4

Stackable basin model 1/4 - Bac empilable mod 1/4

Stapelbare schüssel mod 1/4 - Bandeja honda apilable mod. 1/4

Cod.	h mm	(Euro pcs)	master	Euro master
7PP14200	200	7,66	12	91,88
7PP14150	150	6,59	24	158,14
7PP14100	100	4,67	12	55,98
7PP14065	65	4,42	24	106,06



BACINELLA SOVRAPPONIBILE MOD. 1/6

Stackable basin model 1/6 - Bac empilable mod 1/6

Stapelbare schüssel mod 1/6 - Bandeja honda apilable mod. 1/6

Cod.	h mm	(Euro pcs)	master	Euro master
7PP16200	200	6,61	12	79,28
7PP16150	150	4,95	24	118,86
7PP16100	100	3,47	24	83,38
7PP16065	65	3,37	24	80,76



BACINELLA SOVRAPPONIBILE MOD. 1/9

Stackable basin model 1/9 - Bac empilable mod 1/9

Stapelbare schüssel mod 1/9 - Bandeja honda apilable mod. 1/9

Cod.	h mm	(Euro pcs)	master	Euro master
7PP19100	100	3,05	24	73,08
7PP19065	65	2,77	24	66,36



COPERCHIO

Lid - Couvercle - Deckel - Tapa

Cod.	mod.	(Euro pcs)	master	Euro master
7PP11000	1/1	6,24	12	74,88
7PP12000	1/2	3,68	24	88,20
7PP13000	1/3	3,52	24	84,46
7PP14000	1/4	2,76	24	66,16
7PP16000	1/6	2,21	24	53,04
7PP19000	1/9	1,99	48	95,66



MULTIPLI: LE COMBINAZIONI

Multiples: the combinations

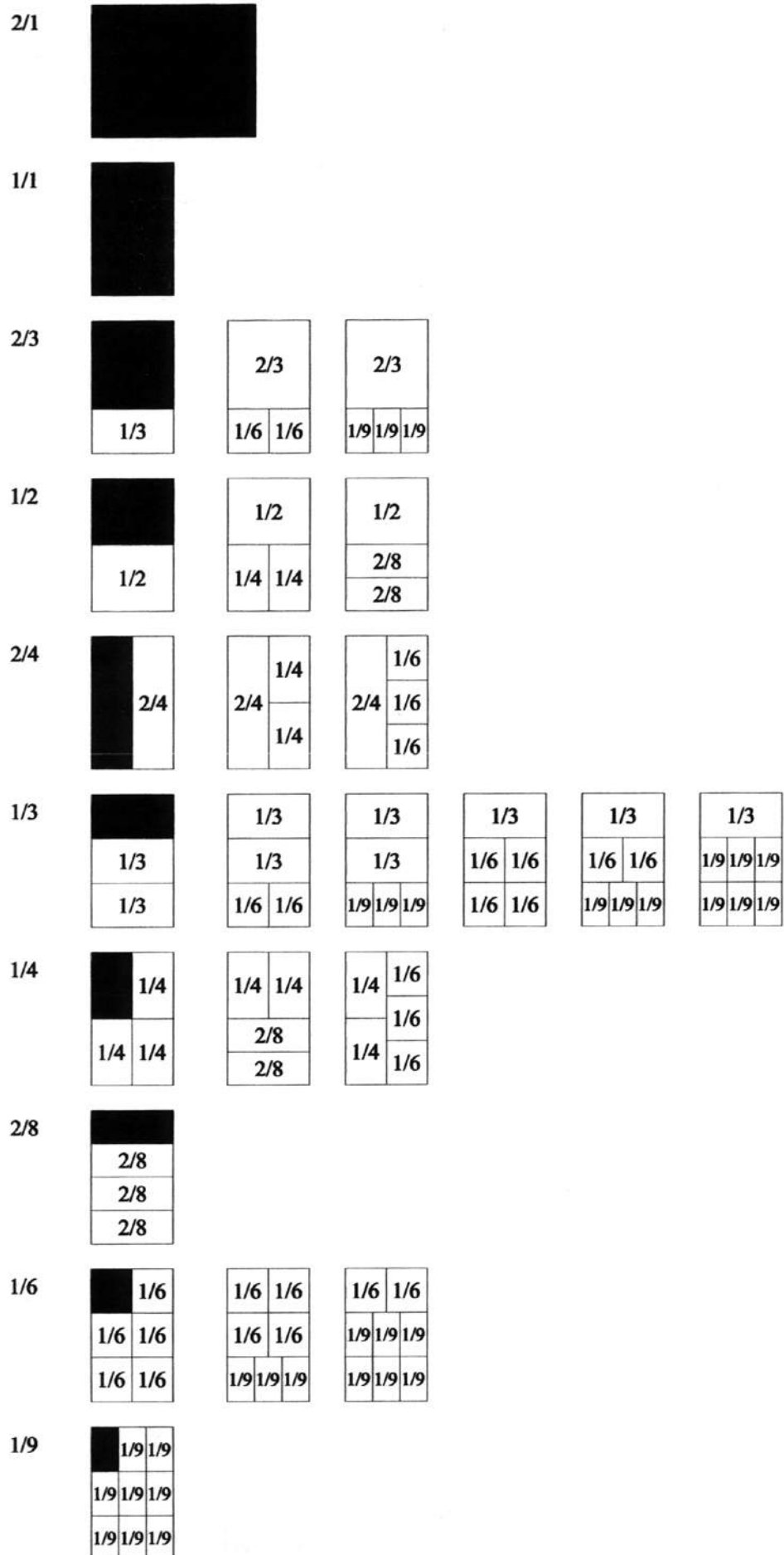

CARATTERISTICHE TECNICHE

Technical informations

ACCIAIO E SPESSORI la serie Gastronorm è prodotta con acciaio AISI 304, chiamato anche 18/10, negli spessori:

-1 mm per i modelli 2/1

-da 0.6 a 0.8 per le altre pezzature restanti

LUCIDATURA le altezze 100, 150, 200 sono sottoposte ad una operazione di normalizzazione termica e poi lucidate mediante burattatura. Oggetti di grandi dimensioni sono puliti per via elettrolitica. Le altezze 65, 40 e 20 vengono prodotte con acciaio BA e sottoposte a trattamento chimico che permette di ottenere una lucidatura omogenea su tutta la superficie.

CONFEZIONE ogni singolo pezzo è sottoposto a lavaggio speculare ad alta temperatura 90° e confezionato in polipropilene pronto per l'uso già sterilizzato.

CAPACITÀ i raggi ridotti al minimo offrono il massimo della capienza nel minimo ingombro.

MATERIALI sono tutti certificati ed idonei al contatto con gli alimenti ai sensi dell' DM. 25-1-1992 art. 4-5° comma D.L. 208 e DIR. CEE 89/109.

LAVAGGIO resistenti all'uso prolungato in lavastoviglie.

MISURE in accordo con gli standard internazionali della CEE doc. CEN/TC 194 EN631-1.

THE STEEL AND THE THICKNESSES the Gastronorm range is made of AISI 304 steel also called 18/10, in the following thicknesses:

-1 mm for the 2/1 models

-from 0.6 to 0.8 for the remaining sizes

POLISHING heights 100, 150 and 200 are thermally normalised and then polished by tumbling. Large items are etch cleaned. Heights 65, 40 and 20 are made of BA steel and are subjected to a chemical treatment permitting the attainment of even polishing over the entire surface.

PACKAGING each individual piece is bright washed at the high temperature of 90° and packaged in polypropylene, ready for use already sterilised.

CAPACITY The finely rounded bottom edges offer maximum capacity in the minimum space.

MATERIALS all the materials are certified to be suitable for contact with foodstuffs according to DM. 25-1-1992 art. 4 - 5th para. D.L. 208 and EEC Directive 89/109.

WASHING resistant to prolonged dish-washing.

SIZES in accordance with the international EEC standards doc. CEN/TC 194 EN631-1.





P R E P A R A Z I O N E

P r e p a r a t i o n

L a P r é p a r a t i o n

V o r b e r e i t u n g

P r e p a r a c i ó n



Per alimenti
Suitable for foodstuffs
Apte au contact avec les aliments
Für Lebensmittel
Apto para alimentos



Garantito per lavastoviglie
Dishwasher safe
Inalterable dans lave-vaisselle
Spelmaschinenfest
Apto para lavavajillas

BAGNOMARIA

Bain-marie

BAGNOMARIA CILINDRICO CON MANICO

Cylindrical bain-marie with handle - Bain-marie cylindrique avec manche

Bain-marie zylindrisch mit Stiel - Baño maria cilindrico con mango

Cod. 509031..

Ø cm	h cm	Lt	Euro
14	16	2¼	31,32
16	18	3½	34,82
18	20	5	38,32
20	22	7	46,66



BAGNOMARIA QUADRATO

Square bain-marie - Bain-marie carré - Bain-marie viereckig - Baño maria cuadrado

Cod.	cm	h cm	Lt	Euro
50903003	16	16	3½	55,12
50903005	16	25	5	72,92



COPERCHIO BAGNOMARIA QUADRATO

Square lid - Couvercle carré - Deckel viereckig - Tapa cuadrada

Cod. 50903316

cm	h cm	Euro
16	16	16,58



COLAPASTA

INOX
18/10

Colander

COLAPASTA SFERICO CON BASE

Spherical colander with foot - Passoire sphérique avec base

Küchensieb mit Fuß - Escurridor esférico con base

Cod. 509008..

Ø cm	h cm	Euro
34	20	132,18
40	22	164,64



COLAPASTA

Colander - Passoire - Küchensieb-Escurridera

Cod. 301062..

Ø cm	Euro
22	39,76
24	42,54
26	49,34
28	56,34



COLAPASTA SFERICO CON 1 MANICO E GANCIO

Spherical colander 1 handle and hook - Passoire sphérique 1 manche et crochet

Brühesieb mit Stiel und Haken - Escurridor 1 mango con gancho

Cod. 509007..

Ø cm	h cm	Euro
22	10,5	34,62
24	11,5	36,26
26	13	46,46
28	14	47,48



SCALDAPASTA FORATO CON 1 MANICO E GANCIO

Colander 1 handle and hook - Passoire 1 manche et crochet

Seiher mit Stiel und Haken - Colador 1 mango con gancho

Cod. 509009..

Ø cm	h cm	Euro
18	10,0	34,94
20	11,5	40,98
22	12,5	45,76
24	13,5	56,68



CONO CINESE

Chinois - Chinois - Spitzsieb - Colador chino

Cod.	Ø cm	Euro
78500350	13	11,66
78500351	17	17,44
78500352	19	19,44
78500353	20	22,48
78500354	22	29,10
78500355	24	30,56
78500356	26	34,76



PASSABRODO

Strainer - Passoire pour bouillon - Suppen-filtersieb - Pasacaldo

Cod.	Ø cm	h cm	Euro
71000106	6,3	1,8	3,40
71000114	13	5,5	8,90
71000116	16,5	6,5	13,10
71000118	18,5	8,0	16,30



SCALDAPASTA A SETTORI

Section colander - Passoire à secteurs - Einsatz - Sección para colador

Cod. 509012..

size	Ø cm	h cm	Euro
1/3	34	20,5	45,26
1/4	40	26,5	49,04



SETACCI

Strainers

Finitura esterna ed interna lucida
Outside and inside satin finish

SETACCIO FARINA

Flour strainer - Passoire à farine

Mehlsieb - Cedazo harina

Cod. 509055..

mm	Ø cm	Euro
	21	15,44
2,5x1,4	30	21,32
	35	24,26

mm
2,5x1,4



SETACCIO VELO

Strainer - Passoire

Mehlsieb - Cedazo

Cod. 509056..

mm	Ø cm	Euro
	21	16,38
1,5x1	30	21,32
	35	24,26

mm
1,5x1



SETACCIO PANE

Bread strainer - Passoire à pain

Mehlsieb - Cedazo pan

Cod. 509057..

mm	Ø cm	Euro
	30	21,32
4x3	35	24,26

mm
4x3



SETACCIO PESCE

Fish strainer - Passoire à poisson

Mehlsieb - Cedazo pescado

Cod. 509058..

mm	Ø cm	Euro
	30	23,32
11x9	35	26,72

mm
11x9



Accessories

INSALATIERA BASE PIANA SENZA MANIGLIE

Salad bowl w/handles - Saladier sans poignées - Salatschüssel ohne Griffe - Ensaladera sin asas
Cod. 509038..

Ø cm	h cm	Lt	Euro
16	7	1	12,46
18	8	1½	18,24
22	10	2½	22,58
24	11	3½	25,66
26	12	4½	31,94
28	13	5½	36,16
34	16	12¾	70,14
40	19	16	98,38



INSALATIERA CONICA BORDATA

Conical salad bowl - Saladier conique - Konische Salatschüssel - Ensaladera conica
Cod. 509037..

Ø cm	h cm	Lt	Euro
16	6	1/2	7,78
18	6,8	3/4	9,98
20	7,2	1	12,08
22	7,6	1⅓	14,40
24	9	1¾	16,80
28	10	2¾	21,42
32	11	4¾	29,40
36	13,2	6¾	37,08
40	13,7	8⅓	42,12



BASTARDELLA BASE PIANA CON MANIGLIE

Salad bowl with handles - Saladier sans poignées - Salatschüssel ohne Griffe - Ensaladera sin asas
Cod. 509036..

Ø cm	h cm	Lt	Euro
16	7	1	20,40
18	8	1½	23,48
22	10	2½	29,88
24	11	3½	33,18
26	12	4½	39,66
28	13	5½	44,94
34	16	12¾	82,72
40	19	16	110,42



BASTARDELLA SEMISFERICA CON MANIGLIE

Semispheric-mixing bowl with handles - Saladier hémisphérique avec poignées - Schlagschüssel mit Griffen - Caldero semiesférico con asas
Cod. 509039..

Ø cm	h cm	Lt	Euro
22	12	3	29,26
28	15	6	43,48
34	20	12	86,74
40	22	17	111,04



BASE PER BASTARDELLA SEMISFERICA

Foot for semispheric-mixing bowl - Base pour saladier hémisphérique
Halterung für Schlagschüssel - Base para caldero semiesférico
Cod. 509040..

Ø cm	Euro
22/28	10,92
34/40	19,36



PASSAVERDURA PROFESSIONALE

Professional vegetable mill - Moulin à légumes professionnel - Profipassiergerät
- Pasa-puré profesional
Cod. 509052..

Ø cm	h cm	Euro
32	19	276,58
42	19	287,82



DISCHI RICAMBIO

Spare discs - Disques de rechange
Zusatzscheiben kleine - Discos repuesto
Cod. 97150017 **Euro 20,06**
Cod. 97150018 **Euro 20,06**

MANOVELLA

Crank - Manivelle - Kurbel - Manivela
Cod. I6905006 **Euro 67,10**
Cod. I6905007 **Euro 70,36**

FORMA CRÈME-CARAMEL

Crème caramel mould - Moule pour crème-caramel - Form für crème caramel -
 Molde para flan de caramelo

Cod. 50953107

Ø cm	h cm	Lt	Euro
7	7	0,27	7,42



MATTARELLO

Rolling - Rouleau à pâtisserie - Wellholz - Rodillo de pastelería

Cod. 50908148

lungh cm	Euro
48	41,02



IMBUTO

Funnel - Entonnoir - Trichter - Embudo

Cod. 50907816

Ø cm	Euro
16	19,40



IMBUTO

Funnel - Entonnoir - Trichter - Embudo

Cod. 50907820

Ø cm	Euro
20	22,58



OLIERA PROFESSIONALE BRA

Professional cruet - Ménager professionnelle - Ölkanne - Vinagrera profesional

Cod. 578153..

Lt	Euro
0,75	35,52
1	41,10





P R E S E N T A Z I O N E

P r e s e n t a t i o n

P r é s e n t a t i o n

P r ä s e n t a t i o n

P r e s e n t a c i ó n



Per alimenti
Suitable for foodstuffs
Apte au contact avec les aliments
Für Lebensmittel
Apto para alimentos



Garantito per lavastoviglie
Dishwasher safe
Inalterable dans lave-vaisselle
Spelmaschinenfest
Apto para lavavajillas

VASSOI

Trays

PIATTO OVALE PORTATA BORDATO PESANTE

Edged oval tray - Plateau oval avec bord - Ovale Bratenplatte - Fuente ovalada rebordeada
Cod. 509316..

cm	spess. mm	master	Euro
26x19	0,7	10	16,90
31x21	0,7	10	17,72
36x25	0,7	10	20,82
42x29	0,7	10	24,42
47x34	0,8	10	29,98
53x35	0,8	10	42,96
60x39	0,8	-	51,60
70x46	1,2	-	139,78
85x58	1,2	-	371,00



Cod. 50931699

cm	spess. mm	master	Euro
100x68	1,2	-	451,76

PIATTO OVALE PORTATA BORDATO

Edged oval tray - Plateau oval avec bord - Servierblett - Fuente ovalada rebordeada
Cod. 509333..

cm	spess. mm	master	Euro
19x15	0,6	10	13,28
23x16	0,6	10	14,42
26x20	0,6	10	15,46
29x22	0,6	10	15,86



PIATTO OVALE PORTATA NORMALE

Oval tray - Plateau oval - Einfache ovale Platte - Fuente ovalada
Cod. 509314..

cm	spess. mm	master	Euro
32x22	0,7	10	17,92
40x29	0,7	10	23,12
48x32	0,7	10	30,60



PIATTO OVALE GASTRONOMICO

Oval tray - Plateau oval - Tiefe ovale Platte - Fuente ovalada

Cod. 50931942

cm	spess. mm	master	Euro
42x31	0,7	10	35,44



PIATTO OVALE PORTATA PESCE

Fish tray - Plat oval à poisson - Fischplatte - Fuente ovalada pescado

Cod. 509336..

cm	spess. mm	master	Euro
55x24	1,0	-	41,00
62x27	0,9	-	55,32
70x29	1,0	-	56,00
78x30	1,0	-	81,32
85x33	1,2	-	114,64



Cod. 50933699

cm	Spess. mm	master	Euro
100x34	1,2	-	150,60

VASSOIO TONDO BORDATO

Round edged tray - Plateau rond bordé - Rundes Tablett - Bandeja redonda rebordeada

Cod. 509330..

Ø cm	spess. mm	master	Euro
30	0,7	10	22,46
35	0,8	10	28,94



VASSOIO GRATIN

Serving tray gratin - Plat à gratin - Gratinplatte - Bandeja gratin

Cod. 509368..

cm	spess. mm	master	Euro
40x21	1,0	-	34,52
45x23	1,0	-	41,20
50x27	1,0	-	47,70



VASSOIO RETTANGOLARE

Rectangular tray - Plateau rectangulaire - Tablett - Bandeja rectangular
Cod. 509312..

cm	spess. mm	master	Euro
25x20	1,0	10	19,58
32x25	1,0	10	26,38
36x29	1,0	10	29,56
40x33	1,0	10	32,56
45x35	1,0	-	40,48
48x37	1,0	-	43,36
60x47	1,0	-	67,48



VASSOIO RETTANGOLARE CON MANIGLIE

Rectangular tray with two handles - Plateau rectangulaire à deux manches
Tablett mit zwei Griffen - Bandeja rectangular con asas
Cod. 509313..

cm	spess. mm	master	Euro
48x37	1,0	-	67,16
60x47	1,0	-	92,80



VASSOIO RETTANGOLARE MAGNA CON MANIGLIE

Magna rectangular tray with two handles - Plateau rectangulaire Magna à deux manches -
Magna Tablett mit zwei Griffen - Bandeja rectangular con dos asas
Cod. 509313..

cm - h cm	spess. mm	master	Euro
44x29x3	1,0	-	55,42
50x33x3	1,0	-	63,14



VASSOIO RETTANGOLARE PITAGORA 1929

Rectangular tray - Plateau rectangulaire - Tablett - Bandeja rectangular
Cod. 509373..

cm	Euro
44x29	87,14
50x33	97,44



VASSOIO TONDO BORDATO

Round edged tray - Plateau rond bordé - Rundes Tablett - Bandeja redonda rebordeada
Cod. 509329..

Ø cm	Ø cm IN	spess. mm	master	Euro
34	28,0	0,7	10	29,56
38	32,2	0,7	10	33,48
42	34,4	0,8	10	41,92
46	39,5	0,8	-	49,96
53	45,5	0,8	-	64,38



VASSOIO TONDO BORDATO CON MANIGLIE

Round edged tray with handles - Plateau rond bordé avec poignées
Rundes Tablett mit Griffen - Bandeja redonda rebordeada con asas
Cod. 509327..

Ø cm	spess. mm	master	Euro
42	0,8	-	105,68
46	0,8	-	113,92
53	0,8	-	129,16



VASSOIO TONDO BORDATO BRA

Round tray - Plateau rond - Runde Platte - Bandeja redonda
Cod. 50930641

Ø cm	spess. mm	master	Euro
41	0,8	-	34,56



VASSOIO OVALE BELLA BRA

Round tray - Plateau rond - Runde Platte - Bandeja redonda
Cod. 537614..

cm	spess. mm	Euro
35	1,0	44,66
46	1,0	67,54





TENDER VASSOI 5382

Inox

Made in Italy 

composizione materiale %

Cr	16/18
C	< 0,08
Mn	< 1,0
P	< 0,04
S	< 0,015
Si	< 1,0

-Produzione totalmente italiana.

-Tutti i materiali impiegati sono della migliore qualità e idonei al contatto alimentare ai sensi del DM 25/01/1992 art. 4, 5° comma e della DIR. CEE 89/109.

-Ogni articolo confezionato in busta trasparente.

-All the series are Made in Italy.

-All the material used in mass production are suitable for food contacts as for the law DM 25/01/1992 art. 4, 5° comma and DIR. CEE 89/109.

-Every piece is in a transparent polybag.

MATERIALE:

AISI 430 CERTIFICATO
(UNI EN 10088-1:2005)
IDONEO AL CONTATTO ALIMENTARE
(UNI EN ISO 8442)

VASSOIO OVALE PORTATA BORDATO TENDER

Edged oval tray - Plateau oval avec bord - Ovale Bratenplatte - Fuente ovalada rebordeada
Cod. 538219..

cm	spess. mm	master	Euro pcs
26x19	0,7	10	7,74
31x21	0,7	10	8,96
36x25	0,7	10	10,52
42x29	0,7	10	12,06
47x31	0,8	10	15,98
53x35	0,8	10	18,24



VASSOIO TONDO CAMERIERE TENDER

Round tray - Plateau rond - Rundes Tablett - Bandeja redonda
Cod. 538259..

Ø cm	h cm	master	Euro pcs
24	1,85	10	8,14
28	1,76	10	10,40
32	1,93	10	12,06
36	1,95	10	13,70



VASSOIO RETTANGOLARE TENDER

 Rectangular tray - Plateau rectangulaire - Tablett - Bandeja rectangular
 Cod. 538272..

cm	spess. mm	master	Euro pcs
25x20	0,6	10	10,52
32x25	0,6	10	12,58
36x29	0,7	10	13,80
40x31	0,7	10	15,76
45x35	0,8	-	18,14
48x37	1,0	-	21,42
60x47	1,0	-	28,94

VASSOIO BAR TENDER

Rectangular tray - Plateau rectangulaire - Tablett - Bandeja rectangular

Cod.	cm	h cm	Euro
53827850	50x10	0,8	19,96
53827852	50x20	0,8	28,24
53827860	60x10	0,8	24,76
53827862	60x20	0,8	29,84
53827870	70x20	0,8	38,12

NEW



ZUPPIERA

Sauce bowl

ZUPPIERA

Soup bowl - Soupière - Suppenterrine - Sopera

Cod. 308772..

Ø cm	h cm	Lt	Euro
18	10	1,5	31,42
22	12	3	37,90
24	13	4	40,48
26	14	4,75	47,18
28	15	6	55,12



COPERCHIO PER ZUPPIERA

Lid for soup bowl - Couvercle pour soupière - Deckel für Suppenterrine - Tapa para sopera

Cod. 308775..

Ø cm	Euro
18	18,44
22	21,12
24	22,66
26	26,78
28	28,44



SALSIERE

Sauce boat

SALSIERA CON BASE

Sauce boat with foot - Saucière sur pied - Sauciere mit Fuß - Salsera con base

Cod. 509153..

cl	master	Euro
9	10	8,60
14	10	9,96
22	10	10,60
28	10	14,84
45	10	21,00



SALSIERA SENZA BASE

Sauce boat without foot - Saucière sans pied - Sauciere ohne Fuß - Salsera sin base

Cod. 50915420

cl	master	Euro
20	10	10,82



CLOCHE

INOX
18/10

Cloche

CLOCHE SEMISFERICA CON POMOLO

Semispheric cloche with knob - Cloche hémisphérique avec pommeau
Speiseglocke kugelförmig mit Griff - Cloche semiesferica con pomo
Cod. 509322..

Ø cm IN	h cm	for round tray Ø cm	Euro
22	12	30	30,18
24	13	30	32,04
26	14	35	37,80
28	15	35	44,82



CLOCHE ROTONDA CON POMOLO

Round cloche with knob - Cloche ronde avec pommeau
Speiseglocke mit Griff - Cloche redonda con pomo
Cod. 509323..

Ø cm IN	for round tray Ø cm	Euro
25	30	36,06
30	35	48,10



CLOCHE OVALE CON POMOLO

Oval cloche with knob - Cloche ovale avec pommeau
Speiseglocke oval mit Griff - Cloche ovalada con pomo
Cod. 509321..

cm IN	for oval tray cm	Euro
32	36	45,42
42	47	60,06



PORTA BURRO

Butter dish

PORTA BURRO DA TAVOLA

Butter dish - Porte beurre - Butterschale - Mantequillera
50933111

Ø cm	h cm	Euro
12,5	8,7	21,54



ACCESSORI STONE WASHED

Stone Washed accessories

ZUPPIERA

Soup bowl - Soupière - Suppenterrine - Sopera
Cod. 539905..

Ø cm	h cm	Lt	Euro
18	10	1,5	63,76
22	12	3	78,18
24	13	4	90,54
26	14	4,75	105,68
28	15	6	113,20



COPERCHIO PER ZUPPIERA

Lid for soup bowl - Couvercle pour soupière - Deckel für Suppenterrine - Tapa para sopera
Cod. 539906..

Ø cm	Euro
18	44,82
22	51,40
24	57,58
26	65,82
28	75,10

CLOCHE SEMISFERICA CON POMOLO

Semispheric cloche with knob - Cloche hémisphérique avec pommeau
Speiseglocke kugelförmig mit Griff - Cloche semiesferica con pomo
Cod. 539992..

Ø cm	h cm	for round tray Ø cm	Euro
22	12	30	60,26
24	13	30	66,86
26	14	35	77,66
28	15	35	85,70



SALSIERA CON BASE

Sauce boat with foot - Saucière sur pied - Sauciere mit Fuß - Salsera con base
Cod. 53998014

cl	Euro
14	20,70







U T E N S I L I

T o o l s

U s t e n s i l e s

Z u b e h ö r

U t e n s i l i o s



Per alimenti
Suitable for foodstuffs
Apte au contact avec les aliments
Für Lebensmittel
Apto para alimentos



Garantito per lavastoviglie
Dishwasher safe
Inalterable dans lave-vaisselle
Spuelmaschinenfest
Apto para lavavajillas

MESTOLAME UNIPEZZO PESANTE

One-piece ladle

MESTOLO UNIPEZZO

One-piece ladle - Louche monobloc

Suppenshöpfer einteilig - Cazo una piez

Cod. 509258..

Ø cm	lungh. cm	Euro
6	28	7,10
8	34	8,16
9	37	11,24
10	37	11,46
11	37	12,00
12	38	15,80
14	57	19,30
16	61,5	30,64



MESTOLO UNIPEZZO FORATO

Slotted one piece ladle - Louche monobloc avec trous

Löcher Suppenshöpfer einteilig - Cazo una pieza agujerz

Cod. 509226..

Ø cm	lungh. cm	Euro
6	28	7,42
8	34	7,96
10	37	11,46
12	38	16,64
16	61,5	27,80

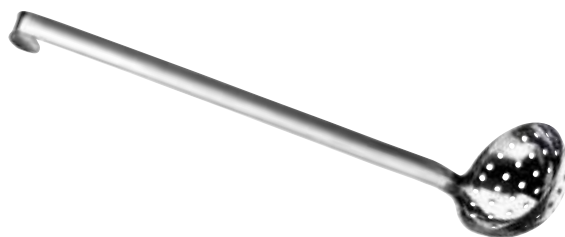

SCHIUMAROLA UNIPEZZO

One-piece skimmer - Ecumoire monobloc

Schaumlöffel einteilig - Espumadera una piezz

Cod. 509269..

Ø cm	lungh. cm	Euro
11	37	10,18
12	38	10,92
14	42	15,06
16	57,5	20,56
18	61	25,12



MESTOLO UNIPEZZO SALSA

One piece sauce ladle - Sauce louche monobloc

Sauce Löcher Suppenschopfer - Cazo una pieza por salsa

Cod. 50926300

cm	Euro
27	4,98



SPATOLA UNIPEZZO

One piece spatula - Spatule

Spachtel - Espátula

Cod.	cm	Euro
50923910	46	13,90
50923912	55	17,28



PALA FRITTO UNIPEZZO NUOVA FORATURA

One piece spatula - Pelle monobloc

Bratenwender einteilig - Pala fritos una pieza

Cod.	cm	Euro
50923010	46	13,36
50923012	55	17,60



FORCHETTONE UNIPEZZO

One-piece serving fork - Fourchette à servir monobloc

Fleischgabel einteilig - Tenedor una pieza

Cod. 50926600

cm	Euro
50	23,74



FORCHETTONE UNIPEZZO PESANTE 3 PUNTE

One-piece 3 prongs serving fork - Fourchette à servir monobloc 3 dents

Fleischgabel einteilig mit 3 zinken - Tenedor una pieza con 3 púas

Cod. 509267..

cm	Euro
50	25,76
70	31,06



NUOVO CUCCHIAIONE FONDO UNIPEZZO

One piece deep serving spoon - Profond cuiller à servir monobloc

Bratenloffel tief einteilig - Cucharon una pieza profundo

Cod. 50926700

cm	Euro
46	12,62



PALA FRITTO UNIPEZZO

One-piece spatula - Pelle monobloc

Bratenwender einteilig - Pala fritos una pieza

Cod. 50927700

cm	Euro
36	9,02



CUCCHIAIONE UNIPEZZO

One-piece serving spoon - Cuiller à servir monobloc

Bratenlöffel einteilig - Cucharon una pieza

Cod. 50926200

cm	Euro
35	8,28



FORCHETTONE UNIPEZZO

One-piece serving fork - Fourchette à servir monobloc

Fleischgabel einteilig - Tenedor una pieza

Cod. 50926500

cm	Euro
35	7,32



FRUSTE

Wisk

FRUSTA
Whisk - Fouet
Schneebesen - Batidor
Cod. 509164..

cm	Euro
25	6,26
30	6,78
35	7,32
40	8,06
45	10,92
50	11,24
55	14,98
60	16,02



UTENSILI DA CUCINA

INOX
18/10

Kitchen tools

SPATOLA DRITTA

Slimline spatula - spatule droite

Palette lang - espátula

Cod.	cm	Euro
78500410	16	5,04
78500412	20	5,36
78500413	23,5	5,78
78500414	29	6,30



SPATOLA DRITTA CON PIEGA

Turner round and flexible spatula - spatule pliée

Winkelpalette - espátula corta

Cod.	cm	Euro
78500420	18	7,56
78500421	20	7,88
78500422	25	8,30



SPATOLA PER CUCINARE

Grill scraper spatula - spatule de chef

Grillpalette - espátula cocinero

Cod.	cm	Euro
78500430	7,5	5,88
78500431	10	7,04
78500432	12,5	7,46
78500433	15	8,10



BATTICARNE PROFESSIONALE MANICO ACCIAIO

Meat mallet with steel handle - Battoir à viande avec manche en acier
Fleischklopper - Picador de carne con mango de acero

Cod.	gr	Euro
50907306	600	21,94
50907315	1500	48,06



ROMPINOCI 2 NICCHIE

Nutcracker - Casse-noix - Nussknacker - Cascanueces
Cod. 50916001

master	Euro
40	10,10



CAVATAPPI 2 LEVE

Cork screw - Tirebouchon - Korkenzieher - Sacacorchos
Cod. 50916200

master	Euro
72	5,98



TRINCIAPOLLO CON MOLLA INTERNA

Poultry shears (internal spring) - Coupe-volailles (ressort intérieur)
Geflügelschere (Interne Feder) - Tijeras para aves
Cod. 50907400

cm	master	Euro
25	30	21,42



RACCOGLI BRICIOLE

Crumb collector - Ramasse-miettes - Tischkrümelsammler - Recoge migas
Cod. 50916600

master	Euro
240	1,86



APPENDI ORDINI IN ALLUMINIO

Order rack - barre porte commandes

Halter für Bestellbelege - Barra de aluminio porta nota

Cod. 78500325

cm	Euro
91	23,74



MOLLE PROFESSIONAL

Professional tongs

MOLLA ARROSTO PROFESSIONAL

Roast meat tong - Pince à rôti

Bratenzange - Pinza para asado

Cod. 50919701

lungh. cm	master	Euro
26	12	14,30



MOLLA SPAGHETTI PROFESSIONAL

Spaghetti tong - Pince à spaghetti

Spaghettizange - Pinza para espaguetis

Cod. 50919601

lungh. cm	master	Euro
26	12	15,30



MOLLA GASTRONORM PROFESSIONAL

Gastronorm tong - Pince gastronorm

Gastronormzange - Pinza gastronorm

Cod. 50919901

lungh. cm	master	Euro
26	12	16,70



MOLLA PANE PROFESSIONAL

Bread tong - Pince à pain
Brotzange - Pinza para pan
Cod. 50919501

lungh. cm	master	Euro
26	12	14,80



MOLLA INSALATA PROFESSIONAL

Salad tong - Pince à salade
Salatzange - Pinza para ensalada
Cod. 50919001

lungh. cm	master	Euro
26	12	15,30



PINZA DEL CUOCO

Chef tong - Pince de chef
Chefzange - Pinza del cocinero
Cod. 588183..

lungh. cm	master	Euro
30	12	4,70
35	12	5,20
40	12	5,60



NEW

PINZA DEL CUOCO

Chef tong - Pince de chef
Chefzange - Pinza del cocinero
Cod. 50918131

lungh. cm	master	Euro
31,5	-	4,70



IN ESAURIMENTO / OUT OF STOCK

MOLLE BUFFET

Buffet tongs

MOLLA SERVIZIO BUFFET
serving tongs
Cod. 58137224

lungh. cm	master	Euro
24	12	5,20



MOLLA ARROSTO BUFFET
roast meat tongs
Cod. 58136024

lungh. cm	master	Euro
24	12	5,20



MOLLA UNIVERSALE BUFFET
all purpose tongs
Cod. 58137324

lungh. cm	master	Euro
24	12	5,20



MOLLA PANE BUFFET
bread tongs
Cod. 58136824

lungh. cm	master	Euro
24	12	5,20



MOLLA INSALATA BUFFET
salad tongs
Cod. 58136620

lungh. cm	master	Euro
20	12	4,90



MOLLA MULTIUSO BUFFET
multi purpose tongs
Cod. 58137524

lungh. cm	master	Euro
24	12	5,20



MOLLA DOLCE BUFFET
cake tongs
Cod. 58136124

lungh. cm	master	Euro
24	12	5,20



MOLLA SPAGHETTI BUFFET
spaghetti tongs
Cod. 58136924

lungh. cm	master	Euro
24	12	5,20



MOLLA VERDURE BUFFET
vegetables tongs
Cod. 58137424

lungh. cm	master	Euro
24	12	5,20



MOLLE EASY LINE

Easy line tongs



MOLLA DOLCE

Cake tongs - Pince à gâteau

Gebäckzange - Pinza para pastel

Cod. 50919400

lungh. cm	master	Euro
20	120	2,80



MOLLA PANE

Bread tongs - Pince à pain

Brotzange - Pinza para pan

Cod. 50919500

lungh. cm	master	Euro
22	120	3,00



MOLLA SPAGHETTI

Spaghetti tongs - Pince à spaghetti

Spaghetti-Zange - Pinza para espaguetis

Cod. 50919600

lungh. cm	master	Euro
20	120	2,80



MOLLA ARROSTO

Roast tongs - Pince à rôti

Bratenzange - Pinza para asado

Cod. 50919700

lungh. cm	master	Euro
21	120	2,80



MOLLA LUMACHE

Snails tongs - Pince à escargots

Schneckenzange - Pinza para caracoles

Cod. 50919800

lungh. cm	master	Euro
16	24	4,50



MOLLA ZUCCHERO INOX

Sugar tongs - Pince à sucre

Zuckerzange - Pinza para azucar

Cod. 50919100

lungh. cm	master	Euro
11	200	1,20



MOLLA GHIACCIO ELITE

Ice tongs Elite - Pince à glace Elite

Eiszange Elite - Pinza para hielo

Cod. 50918900

lungh. cm	master	Euro
15	24	3,92



MOLLA GHIACCIO DENTATA INOX 18/10

Ice tongs inox 18/10 - Pince à glace inox 18/10

Eiszange mit Zähnen inox 18/10 - Pinza para hielo inox 18/10

Cod. 50919300

lungh. cm	master	Euro
16	80	7,30



MOLLA GHIACCIO

Ice tongs - Pince à glace
Eiszange - Pinza para hielo
Cod. 50919200

lung. cm	master	Euro
13	200	2,20



PINZA AFFETTATI

Sliced meat tongs - Pince à charcuterie
Aufschnittzange - Pinza para embutidos
Cod. 50907100

lung. cm	master	Euro
10	100	6,98



PINZA CUOCO PUNTE PIEGATE

German tong bend - pince de chef
Chefzange - Pinza cocinero

Cod.	cm	Euro
78500440	35	7,88
78500441	45	9,88



Cake tongs

FORBICE DOLCE

Cake tongs - Pince à gâteau

Gebäckschere - Pinza para pastel

Cod. 50918000

lungh. cm	master	Euro
20	120	5,56



FORBICE DOLCE BUFFET

Cake tongs - Pince à gâteau

Gebäckschere - Pinza para pastel

Cod. 581307..

lungh. cm	master	Euro
16	12	9,30
20	12	10,80



NEW

SERIE ELLISSE

Ellisse utensils



PASSA THE

Tea strainer - Passoire in the

Teesieb - Filtro para té

Cod. 78000238

lungh. cm	master	Euro
22	24	7,00



PALA TAGLIA FORMAGGI

Cheese slicer - Pelle coupe fromage

Käsehobel - Pala cortar quesos

Cod. 78000265

lungh. cm	master	Euro
21	24	6,50



PALA TORTA SEGHETTATA

Cake server - Pelle à tarte dentelée

Tortenheber - Pala servir pastel

Cod. 78000259

lungh. cm	master	Euro
26	24	6,36



PALA PIZZA SEGHETTATA

Pizza pie-cutter - Pelle à pizza dentelée

Pizzacheber - Pala cortar pizza

Cod. 78000232

lungh. cm	master	Euro
27	24	6,58



PALA UOVO

Egg lifter - Pelle à oeufs

Durchbrochener Pfannenwender - Pala para huevos

Cod. 78000256

lungh. cm	master	Euro
25	24	6,36



FRUSTA PIATTA

Flat whisk - Fouet plat

Platter Schneebesens - Batidor llano

Cod. 790414..

lungh. cm	master	Euro
20	24	4,32
25	24	4,84



GRATTUGGIA PICCOLA DA TAVOLO

Fine handy grater - Râpe petite

Muskatreibe - Rallador de mesa

Cod. 78002806

lungh. cm	master	Euro
26	24	5,10



GRATTUGGIA PIATTA DA TAVOLO

Fine handy grater - Râpe platte

Zitronenreibe - Rallador llano de mesa

Cod. 78002807

lungh. cm	master	Euro
24	24	5,72



CUCCHIAIO ARRICCIABURRO

Butter curler - Cuiller coquilleur à beurre

Butterformer - Rizador de mantequilla

Cod. 78000233

lungh. cm	master	Euro
18	24	3,92



FORCHETTA CARNE 2 PUNTE

Utility fork - Fourchette à viande 2 dents

Fleischgabel - Tenedor carne

Cod. 78000230

lungh. cm	master	Euro
18,5	24	4,56



ARRICCIABURRO

Butter curler - Coquilleur à beurre

Butterroller - Rizador de mantequilla

Cod. 78000269

lungh. cm	master	Euro
19	24	4,24



DOSATORE GELATO

Ice-cream scoop - Portionneur à glace

Eisportionierer - Dosificador helado

Cod. 78000268

lungh. cm	master	Euro
23,5	24	6,48



SCAVINO 22 mm

Melon baller - Creuse pommes de terre

Kugelausstecher - Vaciador

Cod. 78000228

lungh. cm	master	Euro
18	24	4,36



SCAVINO 28 mm

Melon baller - Creuse pommes de terre

Kugelausstecher - Vaciador

Cod. 78000229

lungh. cm	master	Euro
18,5	24	4,66



FORCHETTA PATATE

Potato fork - Fourchette à pommes de terre

Kartoffelgabel - Tenedor de patatas

Cod. 78000234

lungh. cm	master	Euro
16	24	4,46



PELAPATATE

Peeler - Eplucheur à pommes de terre

Sparschäler - Pelapatatas

Cod. 78000271

lungh. cm	master	Euro
18,5	24	3,60



RIGA LIMONI

Lemon zester - Zesteur

Fadenschneider - Pelador

Cod. 78002805

lungh. cm	master	Euro
15,5	24	4,36



PELAPATATE MULTIUSO

Peeler - Eplucheur

Sparschäler - Pelador multiuso

Cod. 78000225

lungh. cm	master	Euro
18,5	24	4,36



APRIBOTTIGLIA E FORA LATTINE

Bottle opener - Décapsuleur

Kapselheber - Abrebotellas

Cod. 78000255

lungh. cm	master	Euro
18,5	24	4,98



SEPARATORE UOVA

Egg divider - Séparateur jaune d'oeuf

Eiertrenner - Separador de claras

Cod. 78000266

lungh. cm	master	Euro
20,5	24	4,98



APRIBARATTOLI UNIVERSALE

Jar opener - Ouvre bocaux

Deckelöffner - Abridor de tarros

Cod. 78000901

lungh. cm	master	Euro
23,5	24	15,38



APRISCATOLE

Can opener - Ouvre-boîtes

Dosenöffner - Abrelatas

Cod. 78000682

lungh. cm	master	Euro
20	24	15,38



SPREMIAGLIO

Garlic press - Presse-ail

Knoblauchpresse - Ex-primeajos

Cod. 78000868

lungh. cm	master	Euro
28,5	24	15,38



CANNULA LEVA TORSOLO

Apple corer - Vide-pommes

Apfelausstecher - Decorazonador

Cod. 78000227

lungh. cm	master	Euro
18,5	24	4,36



GRATTACAROTE

Vegetable scraper - Eplucheur carottes
 Karottenschaber - Pelador de zanahorias
 Cod. 78000267

lungh. cm	master	Euro
23,5	24	3,50



MANARETTA

Meat cleaver - Couperet
 Käsehackbeil - Macheta
 Cod. 78000251

lungh. cm	master	Euro
23,5	24	8,06



MANARETTA PICCOLA

Meat cleaver - Couperet petit
 Käsehackbeil - Macheta pequeña
 Cod. 78000250

lungh. cm	master	Euro
20,5	24	6,26



COLTELLO FORMAGGIO 2 PUNTE

Cheese knife - Couteau à fromage
 Käsemesser - Cuchillo queso
 Cod. 78002803

lungh. cm	master	Euro
24,5	24	4,46



COLTELLO DA CUCINA LUNGO SEGHETTATO (LAMA cm 17)

Kitchen knife - Couteau à viande

Brotmesser - Cuchillo carne

Cod. 78002801

lungh. cm	master	Euro
29	24	4,88



COLTELLO MEDIO SEGHETTATO

Kitchen knife - Couteau de cuisine moyen

Tomatenmesser - Cuchillo de cocina medio

Cod. 78002804

lungh. cm	master	Euro
24	24	3,92



COLTELLO BISTECCA

Steak knife - Couteau à bifteck

Küchenmesser cm10 - Cuchillo chuletero cm 10

Cod. 78002802

lungh. cm	master	Euro
22	24	4,36



COLTELLO SPELUCCHINO

Paring knife - Couteau office

Küchenmesser cm7,5 - Cuchillo chuletero cm 7,5

Cod. 78002800

lungh. cm	master	Euro
19,5	24	4,14



TAGLIA PASTA

Pastry cutter - Roulette coupe-pâte

Plate Teigrädchen - Rodillo cortar pasta

Cod. 78000242

lungh. cm	master	Euro
18,5	24	4,88



TAGLIA PIZZA

Pizza pie cutter - Roulette coupe-pizza

Pizza/Teigrädchen - Rodillo cortar pizza

Cod. 78000243

lungh. cm	master	Euro
18,5	24	4,88



TAGLIA PASTA/PIZZA 2 RUOTE

2 Wheels pastry/pizza cutter - Coupe-pizza à 2 roulettes

Doppelteigrädchen - Cortador de pasta/pizza 2 rodillos

Cod. 78000244

lungh. cm	master	Euro
14	24	5,42



SPATOLA LUNGA

Long spatula - Spatule longue

Schnale Wender -Espátula larga

Cod. 78000264

lungh. cm	master	Euro
34	24	7,64



SPATOLA LARGA

Big spatula - Spatule large
Breiter Wender - Espátula an
Cod. 78000270

lungh. cm	master	Euro
26,5	24	8,70



SCHIACCIA PATATE

Potato masher - Presse-purée
Kartoffelstampfer - Prensa-puré
Cod. 78000549

lungh. cm	master	Euro
30	24	11,46

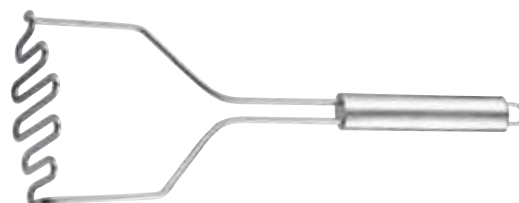

CUCCHIAIONE

Serving spoon - Cuiller de service
Servierlöffel - Cuchara servir
Cod. 7805217B

lungh. cm	master	Euro
32,5	24	8,38



CUCCHIAIONE FORATO

Slotted spoon - Cuiller de service perforé
Gelochter Servierlöffel - Cuchara servir perforada
Cod. 7805218B

lungh. cm	master	Euro
32,5	24	8,48



FORCHETTONE

Fork - Fourchette de service

Serviergabel - Tenedor servir

Cod. 7805215B

lungh. cm	master	Euro
32	12	8,06



MESTOLO cm 9

Soup ladle - Louche

Suppenlöffel - Cazo sopa

Cod. 7805211B

lungh. cm	master	Euro
30	12	11,78



MESTOLO cm 6

Soup ladle - Louche

Saucenlöffel - Cazo sopa

Cod. 7805212B

lungh. cm	master	Euro
28	12	10,82



SCHIUMAROLA cm 11

Skimmer - Ecumoire

Schaumlöffel - Espumadera

Cod. 7805213B

lungh. cm	master	Euro
36,5	12	10,50



PALA FRITTO

Turner - Pelle avec trous

Bratenwender - Pala fritos

Cod. 7805214B

lungh. cm	master	Euro
33	12	8,48



APPENDINO 5 POSTI

Hanger 5 hooks - Barrette 5 pièces

Hängeleiste 5 plätze - Asta colgador 5 ganchos

Cod. 71000013

lungh. cm	master	Euro
33	24	7,32



BARBEQUE

Barbeque

MOLLA BARBEQUE

Barbeque tongs - Pince à barbeque

Barbecue-zange - Pinza para barbacoa

Cod. 50918301

lungh. cm	master	Euro
42,5	6	17,18



PALA BARBEQUE

Barbeque turner - Pelle à barbeque

Barbecue-wender - Pala para barbacoa

Cod. 50918302

lungh. cm	master	Euro
44,5	6	13,90



FORCHETTONE BARBEQUE

Barbeque fork - Fourchette à barbeque

Barbecue-gabel - Tenedor para barbacoa

Cod. 50918303

lungh. cm	master	Euro
44,5	6	11,14



SPAZZOLA BARBEQUE

Barbeque brush - Pinceau barbeque
 Barbecue-Bürste - Brocha - barbacoa
 Cod. 50918304

lungh. cm	master	Euro
44,5	6	14,42



SET 4 PZ BARBEQUE

4 pc barbeque set - Barbeque set 4 pièces
 4 tlg barbecue-set - Set 4 piezas barbacoa
 Cod. 50918300

Euro 54,92



PIATTO PIANO

Flat Plate - Assiette Platte

Flacher Teller - Plato Llano

Cod. 50911022

Ø cm	spess. mm	Euro
22	0,7	12,36



PIATTO FONDO

Deep Plate - Assiette Creuse

Tiefer Teller - Plato Hondo

Cod. 509111..

Ø cm	spess. mm	Euro
20	0,7	11,34
22	0,7	12,98



PIETANZIERA ROTONDA SENZA GUARNIZIONE

Serving dish - Gamelle ronde

Vorratsdose ohne dichtung - Fiambrera redonda

Cod. 50906512

Ø cm	h cm	Lt	Euro
12	6	0,67	24,20



SCODELLA SENZA ALETTE

Bowl - Bol

Fingerschüssel - Cuenco Sin Asas

Cod. 509117..

Ø cm	h cm	Lt	Euro
12	7,2	0,6	10,10
14	7,5	0,9	11,14



TAZZA PER BRODO

Soup cup - Tasse à bouillon

Suppenschüssel - Taza de caldo

Cod. 50912511

Ø cm	h cm	Lt	Euro
11,5	6	0,5	12,98



BICCHIERE

Glass - Verre

Glas - Vaso

Cod. 50912000

Ø cm	h cm	Lt	Euro
7,9	7,9	0,29	12,46



LEGUMIERA CON ALETTE

Vegetable dish with handles - Legumier avec poignées

Beilagenschüssel mit Griffen - Legumbrera con asas

Cod. 509045..

Ø cm	h cm	Euro
12	3	12,16
14	4	13,30
18	5,5	16,70
20	6	20,60



VASSOIO 4 SCOMPARTI BORDO PIANO SENZA PIEDINI

Tray 4 sectors

Plateau 4 secteurs, bord plat

Tablett 4 Sektoren mit flachem Rand, ohne Füße idem

Bandeja 4 secciones, bordo llano, sin pies

Cod. 5VS4BPSP

cm	spess. mm	Euro
40x30	0,8	36,76



VASSOIO 5 SCOMPARTI BORDO PIANO SENZA PIEDINI

Tray 5 sectors

Plateau 5 secteurs, bord plat

Tablett 5 Sektoren mit flachem Rand, ohne Füße idem

Bandeja 5 secciones, bordo llano, sin pies

Cod. 5VS5BPSP

cm	spess. mm	Euro
44x35	0,8	39,80



VASSOIO SELF-SERVICE BRA

5 Sectors dish

Plateau Sel-service 5 secteurs

Tablett 5telig

Bandeja autoservicio honda 5 com.

Cod. 53015605

cm	spess. mm	Euro
34x34	0,8	31,24



CUCCHIAIO PER DETENUTI IN ALLUMINIO
E POLIPROPILENE

Convict spoon - Cuiller détenus
Gefangeneloeffel - Cuchara detenido
Cod. 00100001



master	Euro
500 (10x50 pcs)	2,40

FORCHETTA PER DETENUTI IN ALLUMINIO
E POLIPROPILENE

Convict fork - Fourchette détenus
Gefangenegabel - Tenedor detenido
Cod. 00100002



master	Euro
500 (10x50 pcs)	2,40

SCODELLA DETENUTI

Bowl - Bol
Schüssel - Cuenco
Cod. 50911520



Ø cm	h cm	Lt	Euro
22	5	1,2	17,00

PIATTO DETENUTI

Flat Plate - Assiette Platte
Flacher Teller - Plato Llano
Cod. 50910922



Ø cm	spess. mm	Euro
22	0,8	12,78



B A R G E L A T E R I A

B a r - I c e c r e a m

B a r - C r è m e G l a c é e

B a r - E i s

B a r - H e l a d o



Per alimenti
Suitable for foodstuffs
Apte au contact avec les aliments
Für Lebensmittel
Apto para alimentos



Garantito per lavastoviglie
Dishwasher safe
Inalterable dans lave-vaisselle
Spelmaschinenfest
Apto para lavavajillas

COLINO BAR 2 REBBI PESANTE INOX 18/10

Cocktail strainer heavy - Passoire à cocktail

Cocktailsieb - Filtro para cocktail

Cod. 78500381

Euro 5,04



COLINO BAR 2 REBBI LARGO

Cocktail strainer large - Passoire à cocktail

Cocktailsieb - Filtro para cocktail

Cod. 78500380

Euro 6,42



COLINO BAR SEMPLICE

Cocktail strainer 2 mm - Passoire à cocktail

Cocktailsieb - Filtro para cocktail

Cod. 78500385

Euro 8,40



COLINO COCKTAIL ELLISSE

Cocktail strainer - Passoire à cocktail

Cocktailsieb - Filtro para cocktail

Cod. 50951700

cm	master	Euro
22,5	24	8,48



COCKTAIL SHAKER 2 PZ
Shaker - Shaker
Shaker - Coctelera
Cod. 78500301

Lt	Euro
0,63	22,06



COCKTAIL SHAKER DE LUXE INOX 18/10
Shaker - Shaker
Shaker - Coctelera
Cod. 78500300

Lt	Euro
0,35	13,02



SHAKER BOSTON INOX 18/10
Shaker - Shaker
Shaker - Coctelera
Cod. 78500307

Lt	Euro
0,50	13,76



SHAKER INOX 18/10
Shaker - Shaker
Shaker - Coctelera
Cod. 50954206

Lt	Euro
0,60	49,44



SPREMI LIME INOX 18/10

Lime squeezer - lime squeezer
Saftpresse - exprimidor de limón
Cod. 78500305

Euro 2,42



SPREMIAGRUMI

Citrus squeezer - Presse-citron
Zitronenpresse - Exprimidero
Cod. 50953C00

master	Euro
6	23,44



PORTA TOVAGLIOLI

Napkin holder - porte-serviettes
Serviettenhalter - Servilletero
Cod. 55014300

cm	Euro
11,5x8,5	5,56



PORTA BUSTINE

Sugar display -Porte-sachets de thé et sucre
Serviertablett Zucker/Tee - porta sobres azucar
Cod. 55014400

cm	Euro
10,5x5,5	5,26



ZUCCHERIERA OVALE COMPLETA DI 2 CUCCHIAINI MOD. PITAGORA
Oval sugar bowl with 2 tea/spoons - Sucrier oval avec 2 cuillères à café
Ovale Zuckerdose mit 2 Löffeln - Azucarero ovalada con 2 cucharitas
Cod. 50958600

cm	Euro
21x13	68,40



ZUCCHERIERA TONDA COMPLETA DI 2 CUCCHIAINI MOD. PITAGORA
Round sugar bowl with 2 tea/spoons - Sucrier rond avec 2 cuillères à café
Runde Zuckerdose mit 2 Löffeln - Azucarero redonda con 2 cucharitas
Cod. 50958500

Ø cm	Euro
14	56,86



SPILLONE PORTA SCONTRINI
Bill spike - Epingle porte-tickets
Couponnadel - Aguja porta tickets
Cod. 50916500

master	Euro
48	6,14



CAVATAPPI PROFESSIONALE
Professional corkscrew - Tire-bouchon
Profikorkenzieher - Sacacorchos
Cod. 50953B00

master	Euro
60	3,72



DOSATORE DOPPIO ELLISSE

(1 oz - 2 oz)

Double jigger - Doseur double

Doppeldosiereinrichtung - Dosificador doble

Cod. 50951600

cm	master	Euro
23	12	8,60



MIXER ELLISSE

Mixer - Mélangeur

Mixer - Mezllador

Cod. 50951800

cm	master	Euro
25	24	3,92



SESSOLA

Ice/sugar big spoon - cuillère à farine et glaçons

Serviertablett Zucker/Tee - Librador

Cod.	Lt	Euro
78500315	0,06	6,72
78500317	0,250	9,66
78500318	0,500	15,86
78500319	0,700	16,38



VASSOIO BAR TENDER

Rectangular tray - Plateau rectangulaire - Tablett - Bandeja rectangular

Cod.	cm	h cm	Euro
53827850	50x10	0,8	19,96
53827852	50x20	0,8	28,24
53827860	60x10	0,8	24,76
53827862	60x20	0,8	29,84
53827870	70x20	0,8	38,12



NEW



TAPPO CHIUDI E VERSA CHAMPAGNE INOX 18/10

Close and pour champagne stopper inox 18/10 - Bouchon à champagne inox 18/10 - Champagnerverschluss Inox 18/10 mit Ausgießer Gießen und Schließen - Tapón "cierra y sirve" vino pvc

Cod. 50953305

Euro 15,06



TAPPO CHIUDI E VERSA VINO PVC BORDEAUX

Close and pour pvc wine stopper inox 18/10 - Bouchon à vin en PVC / bouchon pour bouteille de vin en PVC - Weinverschluss mit Ausgießer Gießen und Schließen - Tapón "cierra y sirve" vino pvc

Cod. 50953307

Euro 5,78



CHIUDIBOTTIGLIA INOX

Stainless steel bottle stopper - Bouchon en inox
Edelstahlflaschenverschluss - Tapon de inox

Cod. 50953A00

master	Euro
60	6,36



FORCHETTINA ANTIPASTO INOX

Hors d'oeuvre fork - Fourchette hors d'oeuvre
Vorspeisegabel - Tenedor

Cod. 19800009

master	Euro
120	0,74

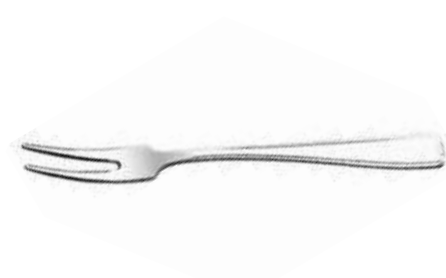

FORCHETTA CARNE TOSCANA

Meat fork - Fourchette à viande
Fleischgabel - Tenedor carne

Cod. 14200043

master	Euro
120	0,94



CUCCHIAINO MOKA INOX INGLESE

Moka spoon - Cuillère à moka

Mokkalöffel - Cucharita moka

Cod.	master	Euro
199000CH	600	0,42



CUCCHIAINO MOKA INOX ECONOMICO

Moka spoon - Cuillère à moka

Mokkalöffel - Cucharita moka

Cod.	master	Euro
19900008	600	0,42



CUCCHIAIO BIBITA

Soda spoon - Cuillère à cocktail

Limolöffel - Cucharita refresco



Cod.	descriz.	cm	Euro pcs	Euro 6 pcs*
2150C636	GAMMA inox 18/10	22	1,98	12,46
1870C636	CAPRI inox	22	1,78	11,26
0810C636	PITAGORA inox 18/10	22	3,02	18,70
2230C636	BRASILIA inox 18/10	22	2,08	13,06
2240C636	AMERICA inox 18/10	22	2,08	13,06
1710C636	BETA inox 18/10	22	1,98	12,46
1980C636	ALBA inox	20,5	1,36	8,74
0800C636	BYRON inox 18/10	22	3,02	18,70
0810C6CG	PITAGORA inox 18/10 (antisc.)	30	5,62	34,30
2030C636	SYNTHESIS inox 18/10	22,1	2,40	14,98
0320C636	STRESA inox 18/10	21	1,56	9,94
2280C636	RITZ inox 18/10	19,5	2,82	17,50
1690C636	PALACE inox 18/10	22	2,40	14,98

*Confezioni con Chiavi 6 pz - ordine minimo 24 Chiavi (1 master) o multipli

*Packaging with "chiavi" 6 pcs - minimum order 24 "chiavi" (1 master) or multiple

POSATE CON CHIAVE Cutlery packed with "chiave" pack



GR 6
607 Cucchiaino
caffè - *Tea/coffee*
spoon - *Cuiller à*
café - *Kaffeelöffel* -
Cuchara café

GR 6
608 Cucchiaino
moka - *Moka*
spoon - *Cuiller à*
moka - *Mokkalöffel* -
Cucharita moka

GR 6
617 Forchettina
dolce 3 spine - *Pastry*
fork - *Fourchette à*
gateau - *Kuchengabel*
3 Zinken - *Tenedor*
postre 3 púas

GR 3
322 Paletta gelato
- *Ice cream spoon*
- *Cuiller à glace* -
Eislöffel - *Cuchara*
para helado

	Modello - Cod.	Euro	Euro	Euro	Euro
	<i>Vittoriale</i> 1640C...	13,66	13,66	17,50	-
	<i>Concept</i> 0450C...	16,78	16,18	18,70	-
	<i>Tecna</i> 0470C...	13,66	13,66	17,50	-
	<i>Olivia</i> 0490C...	13,66	13,66	17,50	-
	<i>Euclide</i> 0480C...	13,66	13,66	-	-
	<i>Swing</i> 0880C...	13,06	12,46	17,50	-
	<i>Palladium</i> 0590C...	13,06	12,46	17,50	6,82
	<i>Ritz</i> 2280C...	14,98	13,66	16,18	7,78
	<i>Settecento</i> 2050C...	11,26	11,26	12,46	-
	<i>Liberty</i> 1660C...	11,86	11,86	16,78	-
	<i>Palace</i> 1690C...	11,26	11,26	12,46	5,92
	<i>Trend</i> 1670C...	10,54	10,54	12,46	-
	<i>Synthesis</i> 2030C...	9,68	9,68	11,26	-
	<i>Solaris</i> 2170C...	10,00	9,94	11,86	-
	<i>America</i> 2240C...	7,50	7,50	9,78	4,66
	<i>Gamma</i> 2150C...	8,84	8,74	8,96	4,16
	<i>Dolphin</i> 13600...	8,14	7,42	9,34	-
	<i>Snake</i> 1140C...	5,62	5,02	-	-

Confezioni con Chiavi 6 pz - ordine minimo 24 Chiavi (1 master) o multipli
Packaging with "chiavi" 6 pcs - minimum order 24 "chiavi" (1 master) or multiple



EUROPA

PALETTA GELATO

Ice cream spoon - Cuillère à glace
Eislöffel - Cuchara parar helado



Cod.	descriz.	cm	master	Euro
19900022	50/P inox	13,2	120	0,94
17100022	BETA inox 18/10	13,6	120	1,26
21500022	GAMMA inox 18/10	13,6	120	1,26
22400022	AMERICA inox 18/10	13,1	120	1,36
22300022	BRASILIA inox 18/10	13,1	120	1,36
22600022	SIRIO inox 18/10	13,7	120	1,66
08100022	PITAGORA inox 18/10	13,6	120	2,08
05900022	PALLADIUM inox 18/10	14,2	120	2,08
16900022	PALACE inox 18/10	14,4	120	1,78
08300022	BAGUETTE inox 18/10	13,7	120	2,08

DOSATORE GELATO

Ice cream scoop - Doseur pour glace
Eisportionierer - Dosificador helado

Cod.	cm	master	Euro
79004018	4,1	12	12,40
79004020	5,0	12	13,46
79004022	6,3	12	14,00



DOSATORE MANICO VUOTO

H-H ice cream soop - portionneur pour glace
Eisportionierer - dosificador helado mango hueco

Cod.	misura	Euro
78500396	medum	14,82
78500397	big	15,66



SPATOLA PER GELATO INOX

Ice cream spatula - Spatule à glace
Eisspachtel - Paleta para helado
Cod. 50952800

cm	master	Euro
18,5	100	4,22



SPATOLA PER GELATO IN POLICARBONATO
 PC ice cream spatula - Spatole à glace en PC
 PC Eisservier - Paleta para helado de PC

Cod.	colour	cm	master	Euro
50952707	black	27	100	3,00
50952708	transparent			



SPATOLA PER GELATO CON MANICO IN PLASTICA
 Ice cream spatula with plastic handle
 Spatule à glace avec manche en plastique
 Eisservier mit Kunststoffgriff
 Paleta para helado con mango de plástico

Cod.	colour	cm	master	Euro
50952701	white	30	100	7,52
50952702	green			
50952703	red			



SPATOLA PER GELATO MANICO IN PLASTICA
 Ice cream spatula with plastic handle
 Spatule à glace avec manche en plastique
 Eisservier mit Kunststoffgriff
 Paleta para helado con mango de plástico

Cod.	colour	cm	master	Euro
50952601	red	26	600	5,46
50952602	blue			
50952603	yellow			
50952604	green			
50952605	white			
50952606	rose			
50952607	black			



PIATTINO CASSATA LISCIO

Ice cream plate - Plat à cassate

Cassata platte - Platilo

Cod. 50952013

Ø cm	master	Euro
13	-	7,74



PIATTINO PER COPPA BORDATO

Edged plate - Plat bordé

Eisschale Untersatz - Platillo

Cod. 50952113

Ø cm	master	Euro
13	-	6,40



COPPA GELATO CONICA

Conical ice cream goblet - Coupe à glace conique

Konische Eisschale - Copa para helado conica

Cod. 50950685

Ø cm	master	Euro
8,5	6	11,46



COPPA GELATO GAMBO BASSO

Ice cream goblet - Coupe à glace

Eisschale niedrig - Copa para helado

Cod. 50950210

Ø cm	master	Euro
10	6	7,32



COPPA GELATO GAMBO ALTO CILINDRICO

Ice cream goblet - Coupe à glace

Eisschale hoch - Copa para helado

Cod. 509504..

Ø cm	master	Euro
9	6	9,98
10	6	10,08



BACINELLA PER GELATO

ice cream basin

36x16,5 cm

Cod.	h cm	Euro
55019108	8	18,80
55019112	12	21,22
55019115	15	35,40
55019118	18	40,86
55019120	20	44,84



BACINELLA PER GELATO

ice cream basin

33x16,5 cm

Cod.	h cm	Euro
55019408	8	18,48
55019412	12	32,24
55019415	15	36,12
55019418	18	41,70
55019420	20	47,88



BACINELLA PER GELATO

ice cream basin

25,8x15,7 cm

Cod.	h cm	Euro
55019712	12	29,52
55019715	15	31,08
55019717	17	34,24



BACINELLA PER GELATO

ice cream basin

36x25 cm

Cod.	h cm	Euro
55019202	2	15,34
55019204	4	20,48
55019205	5	23,22
55019208	8	24,78
55019212	12	44,42
55019215	15	47,16
55019218	18	51,04
55019220	20	55,02



BACINELLA PER GELATO

ice cream basin

21x20 cm

Cod.	h cm	Euro
55019512	12	34,24
55019515	15	35,40
55019517	17	37,38
55019520	20	47,16



BACINELLA PER GELATO

ice cream basin

Cod.	cm	h cm	Euro
55019812	18x16,5	12,6	28,68
55019912	16,5x16,5	12	26,26



BACINELLA PER GELATO

ice cream basin

33x25 cm

cod.	h cm	Euro
55019302	2	15,34
55019304	4	21,22
55019308	8	24,36
55019312	12	44,42
55019315	15	47,16
55019318	18	51,04
55019320	20	55,02



BACINELLA PER GELATO

ice cream basin

42x20 cm

cod.	h cm	Euro
55019615	15	51,04
55019617	17	55,02
55019620	20	60,90
55019625	25	78,54



CARAPINA PER GELATO

20 Ø cm

cod.	h cm	Euro
55012525	25 ECO	43,26
55012625	25	51,04
55012612	12,8	36,54



COPERCHIO IN PLASTICA
plastic lid

cod.	cm	Euro
55013721	21x20	5,78
55013726	26x16,5	5,78
55013733	33x16,5	5,78
55013736	36x16,5	5,78



COPERCHIO PER CARAPINA
cover for ice cream roller container
20 Ø cm

cod.	Euro
55012820	80,54



SUPPORTO PER BACINELLE
support for basin
18x16,5 cm

cod.	Euro
55013818	16,92



SET 2 CARAPINE CON COPERCHIO
 roller container with cover
 for ice cream 2 pcs set
 15 Ø cm

Cod.	cm	Euro
55012736	36x16,5	106,06



PORTA TOVAGLIOLI
 napkin holder

Cod.	cm	h cm	Euro
57010700	10,6x10,6	13,5	22,58





C A F F E T T E R I A

C o f f e e s h o p



Per alimenti
Suitable for foodstuffs
Apte au contact avec les aliments
Für Lebensmittel
Apto para alimentos



Garantito per lavastoviglie
Dishwasher safe
Inalterable dans lave-vaisselle
Spuelmaschinenfest
Apto para lavavajillas

SERIE BELLA BRA

INOX
18/10

Bella coffee pots

CAFFETTIERA BELLA

Coffee pot - Pot à lait/café - Kaffeekanne - Cafetera
Cod. 557600..

Lt	tz/cup	master	Euro
0,25	3	6	46,42
0,50	6	6	53,08
1	12	6	65,06



TEIERA BELLA

Tea pot - Théière - Teekanne - Tetera
Cod. 557640..

Lt	tz/cup	master	Euro
0,15	1	6	42,68
0,25	2	6	49,72
0,50	4	6	55,54



LATTIERA BELLA

Milk pot - Pot à lait - Milchkanne - Lechera
Cod. 557670..

Lt	tz/cup	master	Euro
0,15	1	6	29,92
0,25	3	6	34,32
0,50	6	6	38,32
1	12	6	47,52



ZUCCHERIERA BELLA

Sugar bowl - Sucrier - Zuckerdose - Azucarero
Cod. 557621..

Lt	tz/cup	master	Euro
0,20	4	6	31,68
0,40	8	6	41,52



SERIE CONICA

Conica coffee pots

CAFFETTIERA CONICA

Coffee pot - Pot à lait/café - Kaffeekanne - Cafetera

Cod. 509560..

Lt	Euro
0,33	27,74
0,60	42,00
1	49,80
1,5	54,20
2	65,50
3	74,90



TEIERA CONICA

Tea pot - Théière - Teekanne - Tetera

Cod. 509567..

Lt	Euro
0,36*	35,50
1,25	51,40



LATTIERA CONICA

Milk pot - Pot à lait - Milchkanne - Lechera

Cod. 509573..

Lt	Euro
0,02	12,60
0,10	13,50
0,20	15,90
0,33	20,70
0,60	36,00
1	44,50
1,50	48,20
2	56,50
3	69,10





P A S T I C C E R I A

P a s t r y m a k i n g



Per alimenti
Suitable for foodstuffs
Apte au contact avec les aliments
Für Lebensmittel
Apto para alimentos



Garantito per lavastoviglie
Dishwasher safe
Inalterable dans lave-vaisselle
Spuelmaschinenfest
Apto para lavavajillas

ALZATA FILO PICCOLA

little riser

Cod. 50951028

Ø cm	h cm	Euro
24/28	15	12,90

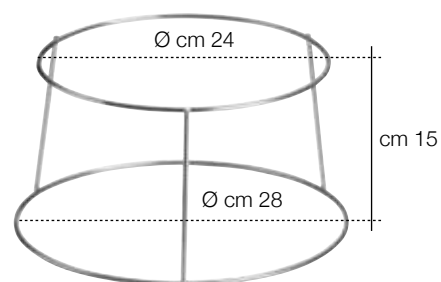

ALZATA FILO GRANDE

big riser

Cod. 50951036

Ø cm	h cm	Euro
32/36	20	15,08

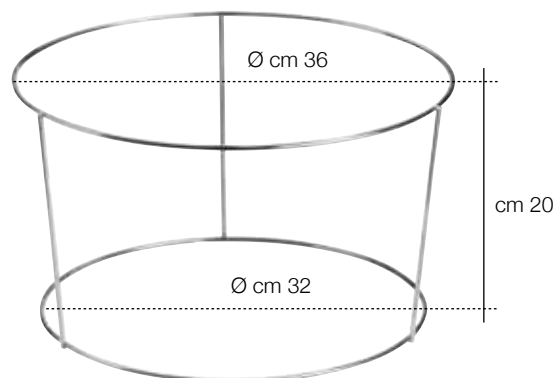

VASSOIO TONDO TENDER

Tender round tray

Cod. 538259..

Ø cm	Euro
24	8,14
28	10,40
32	12,06
36	13,70



CUCCHIAIO

paddle

Cod. 0620MKUL

cm	master	Euro
10	120	78,10



MIXER

mixer

Cod. 0620MKUQ

cm	master	Euro
10	120	62,60



JOLLY

joker

Cod. 0620MKUP

cm	master	Euro
10	120	67,60



VASSOI PER PASTICCERIA

INOX
18/10

Tray

VASSOIO RETTANGOLARE PER PASTICCERIA

Pastry deep tray - Plateau rectangulaire à pâtisserie - Tiefes Kuchentablett -
Bandeja rectangular pastelera

Cod. 50933827

cm	spess. mm	master	Euro
27x20	0,6	-	13,92



VASSOIO TRAMEZZINI IN ACCIAIO 18/0

Tray - Plateau - Tablett - Bandeja

Cod. 53727929

cm - h cm	spess. mm	master	Euro
29x21x2	0,8	10	12,88



VASSOI IMPILABILI

Tray

VASSOIO GN 1/1 IMPILABILE

Tray - Plateau - Tablett - Bandeja

Cod. 50933456

cm - h cm	master	Euro
53x32x7	10	88,48



BACINELLE PER PASTICCERIA

Deet tray

BACINELLA PER PASTICCERIA

Pastry deep tray - Plateau à pâtisserie - Einfaches tiefes Tablett - Bandeja honda pastelera
Cod. 509339..

cm - h cm	spess. mm	master	Euro
25x18x2	0,6	10	17,10
30x22x2	0,7	10	23,80
35x25x2,5	0,8	10	29,06



BACINELLA PER PASTICCERIA

Pastry deep tray - Plateau à pâtisserie - Einfaches tiefes Tablett - Bandeja honda pastelera
Cod. 509339..

cm - h cm	spess. mm	master	Euro
29x21x2	0,8	10	20,10
58x21x2	1,0	-	38,00



VASSOIO RETTANGOLARE PER PASTICCERIA

Pastry deep tray - Plateau à pâtisserie - Einfaches tiefes Tablett - Bandeja honda pastelera
Cod. 50933950

cm	spess. mm	master	Euro
50x36	1	-	36,30







B U F F E T



Per alimenti
Suitable for foodstuffs
Apte au contact avec les aliments
Für Lebensmittel
Apto para alimentos



Garantito per lavastoviglie
Dishwasher safe
Inalterable dans lave-vaisselle
Spelmaschinenfest
Apto para lavavajillas



BUFFET INOX 509

Acciaio inox 18/10

Made in Italy 

La linea Buffet inox è l'elegante coordinato di oggetti per le nuove tendenze di presentazione libero servizio della moderna ristorazione.

LE FUNZIONI:

-Presentazione: per mettere ordine ed esaltare l'immagine della qualità dei cibi proposti.

-Caldo: i chafing dishes mantengono i cibi ad una temperatura ottimale per la conservazione dei sapori; sono disponibili:

1. Versione tradizionale con fornelli per alcool solido

2. Versione con resistenza elettrica che può essere anche usata nel sistema tradizionale.

-Freddo: L'obiettivo è di mantenere i cibi facilmente deteriorabili ad una bassa temperatura, come da grafici specifici. Il raffreddamento avviene mediante i rivoluzionari sacchetti di gel, che si adattano perfettamente alle pareti dei pezzi.

-Tutti i pezzi sono facilmente smontabili e lavabili in lavastoviglie.

The Buffet line elegantly coordinates the objects for the new presentation trend of catering, self-service.

ITS FUNCTIONS

-Presentation: to arrange things in an orderly fashion and highlight the quality image of the food.

-Heating: chafing dishes keep food at an optimum temperature to maintain their flavors; available in:

1. Traditional version with burner holders.

2. Electrical resistance version which can also be used in the traditional way.

-Cooling: the aim is to keep easily perishable food at a low temperature as per the specific graphs. Cooling is carried out with revolutionary gel packs, which adapt well to the walls of the pieces.

-All the pieces are easy to disassemble and are dishwasher safe.

PIATTO FORMAGGI

INOX
18/10



Tray for cheese

PIATTO FORMAGGI CON CUPOLA APRIBILE IN POLICARBONATO INDEFORMABILE CON TAGLIERE IN FAGGIO

Tray for cheese with openable non-deformable polycarbonate cloche with non-deformable laminar beech wooden board

Plateau à fromage avec coupole ouvrable en polycarbonate indeformable avec planche en hêtre lamellaire indeformable

Käseplatte mit holzbrett und rolltop

Bandeja para queso con cúpula abrible de polycarbonato indeformable y tabla de haya laminar indeformable

Cod. 50951448

Ø cm	h cm	Euro
47,5	34	253,86

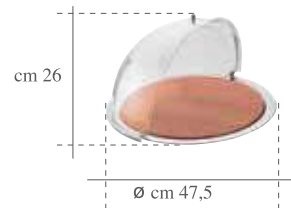

PIATTO FORMAGGI CON TAGLIERE IN FAGGIO LAMELLARE INDEFORMABILE

Tray for cheese with non-deformable laminar beech wooden board

Plateau à fromage avec planche en hêtre lamellaire indéformable

Käseplatte mit formbeständigem brett aus buche-schichtholz

Bandeja para queso con tabla de haya laminar indeformable

Cod. 50951452

Ø cm	h cm	Euro
47,5	2	111,38

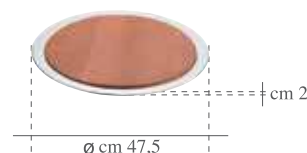

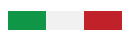

PORTA PANE

Brad trat

PORTA PANE CON CUPOLA APRIBILE IN POLICARBONATO INDEFORMABILE

Bread tray with openable non-deformable polycarbonate cloche

Porte-pain avec coupole ouvrable en polycarbonate indeformable

Btotschale mit Rolltop

Porta-pan con cúpula abriblede policarbonato indeformable

Cod. 50951348

Ø cm	h cm	Euro
47,5	34	253,86



PORTA PANE

Bread basket - Corbeille à pain

Btotschale - Porta pan

Cod. 50951352

Ø cm	h cm	Euro
47,5	10	111,38

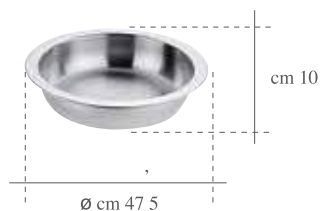



DISTRIBUTORI SUCCHI E BEVANDE CON COLONNA REFRIGERANTE E RUBINETTO TOMLINSON

**Juice and cold drink dispenser with
refrigerating pipe for ice cubes**

DISTRIBUTORE SUCCHI

Juice dispenser
Distributeur de jus
Saftspender
Surtidor de zumos
Cod. 50955416

Ø cm	Lt	Euro
16	4,5	393,12

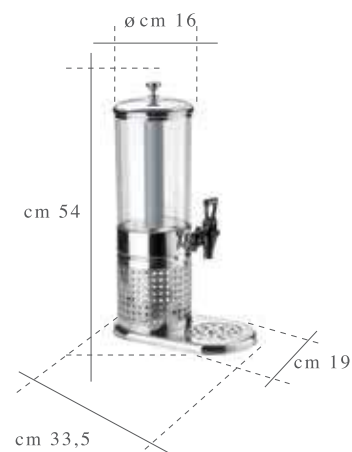

DISTRIBUTORE SUCCHI

Juice dispenser
Distributeur de jus
Saftspender
Surtidor de zumos
Cod. 50955420

Ø cm	Lt	Euro
20	9,5	424,32



DISTRIBUTORI BEVANDE CALDE

INOX
18/10



Hot drink dispenser

DISTRIBUTORE BEVANDE CALDE

CORREDATO DA RESISTENZA

ELETTRICA 220 VOLTS 240 WATTS

Hot drinks dispenser provided with 220 V – 240 w electric resistance

Distributeurs de boissons chaudes avec résistance électrique 220 v – 240 w

Spender für warme getränke ausgestattet mit 220 v – 240 w elektrischer heizung

Distribuidores de bebidas calientes con resistencia eléctrica 220 v – 240 w

Cod. 50959527

Ø cm	Lt	Euro
24	8	651,90

DISTRIBUTORE BEVANDE

Drinks dispenser

Distributeur de boissons

Spender für warme getränke

Distribuidore de bebidas

Cod. 50959524

Ø cm	Lt	Euro
24	8	458,64



Temperatura Temperature (°C)

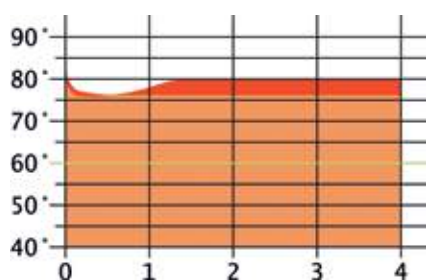

Tempo Time (h)

Diagramma del mantenimento della temperatura
Temperature maintenance diagram

I rubinetti in acciaio verranno
sostituiti con quelli in PPL
Stainless steel faucet will be
change by PPL fauce

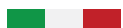

SISTEMI REFRIGERANTI

Refrigerated systems

PORTA YOGURT 19 FORI Ø mm 55
CORREDATO DI REFRIGERANTI
Refrigerated yoghurt dispenser
Porte-yogourt avec réfrigérants
Joghurt-halter mit kühlakku
Porta-yogur con refrigerantes
Cod. 50952947

Ø cm	h cm	Euro
47,5	10	213,20

Temperatura Temperature (°C)



Diagramma del mantenimento della temperatura
Temperature maintenance diagram



PORTA BURRO REFRIGERABILE
Refrigerated butter tray
Porte-beurre réfrigérable
Butterschale mit kühlakku
Porta-mantequilla refrigerable
Cod. 50933136

Ø cm	h cm	Euro
35	6,5	102,50

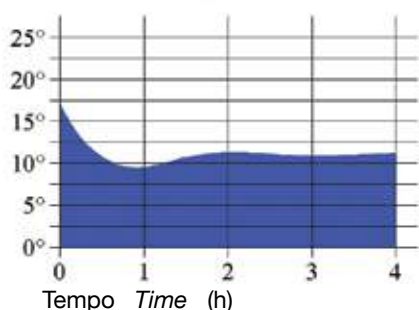
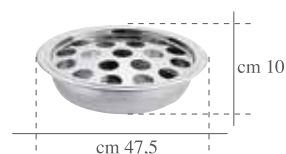
Temperatura Temperature (°C)



Diagramma del mantenimento della temperatura
Temperature maintenance diagram



Contenitore ghiaccio
Ice bucket
Recipient a glace
Eisbehälter
Recipiente para hielo

PIATTO AFFETTATI

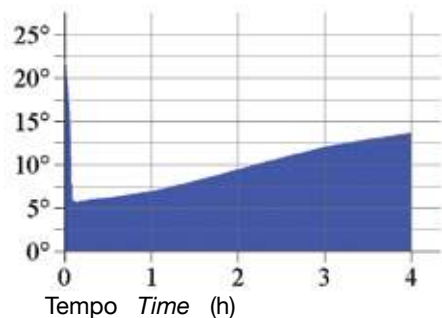
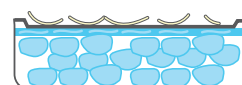
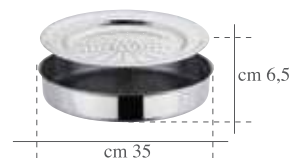
INOX
18/10



Tray for sliced salami

PIATTO AFFETTATI DOPPIA PARETE CON REFRIGERANTI E CUPOLA APRIBILE
IN POLICARBONATO INDEFORMABILE, INFRANGIBILE

Double wall tray for sliced salami and ham provided with refrigerators and non-deformable, unbreakable polycarbonate openable cloche

Plat à charcuterie double paroi avec refrigerants et coupole ouvrable en polycarbonate indeformable, incassable

Aufschnittplatte mit rolltop und kühlakku

Fuente de charcutería doble pared con refrigerantes y cúpula abrible de polycarbonato indeformable, irrompible

Cod. 50952548

Ø cm	h cm	Euro
47,5	29	252,82



PIATTO AFFETTATI

Tray - Plateau - Tablett - Bandeja

Cod. 50952452

Ø cm	Euro
40	38,96



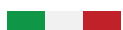

PIATTO AFFETTATI

PIATTO AFFETTATI DOPPIA PARETE CON REFRIGERANTI

Tray with double wall for sliced salami and ham provided with refrigerators

Plat à charcuterie double paroi avec réfrigérants

Aufschnittplatte mit doppelwand und kühlern

Fuente de charcutería doble pared con refrigerantes

Cod. 50952552

Ø cm	h cm	Euro
47,5	5	145,70

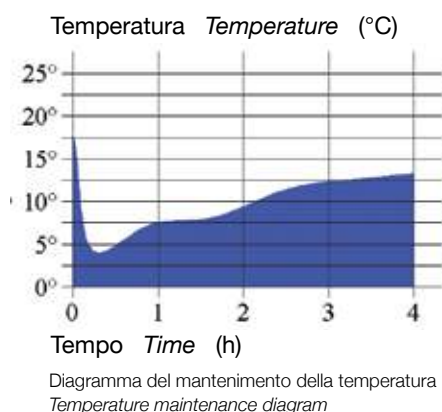
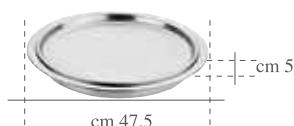

MORSA PROSCIUTTO

Ham clamp - Porte jambon - Schinkenspanner - Porta jamón

Cod. 97200090

cm	h cm	Euro
58	17	193,90



A richiesta è disponibile con base in resina
Resin base available on request
Base en résine disponible sur demande
Auf Anfrage mit Harzbasis
Base de resina disponible bajo pedido

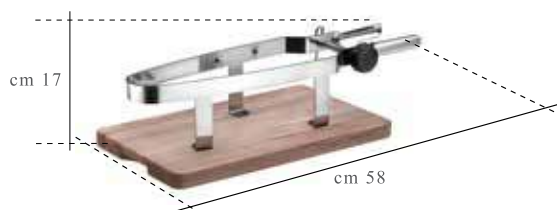

CHAFING DISH

INOX
18/10



Chafing dish

CHAFING DISH QUADRATO GN 2/3 GASTRONORM composto da: Base traforata cm 36,5x33,5x20 - Vasca cm 33,5x30,5x10,5 - Bacinella alimenti cm 33x30x6 - Coperchio rimovibile cm 35x32x6 - 2 Fornelletti inox

· Gastronorm squared chafing dish composed of: Grill - tank - food seat - removable lid - heaters

· Réchaud carré gastronorm composé de: Base percée - cuve - bac aliments - couvercle démontable - fourneaux

· Chafing dish gn 2/3 mit brennpastenbehältern bestehend aus: Siebboden - wanne - lebensmittelbecken abnehmbarem deckel - kocher

· Hornillo cuadrado gastronorm compuesto por: Base perforada - recipiente - depósito alimentos - tapa desmontable - hornillos quemadores

Cod. 30595533

cm	h cm	Euro
46x40	26	343,10

CHAFING DISH QUADRATO GN 2/3 GASTRONORM CORREDATO DA RESISTENZA ELETTRICA 220 VOLTS / 700 WATT composto da: Base traforata cm 36,5x33,5x20 - Vasca cm 33,5x30,5x10,5 - Bacinella alimenti cm 33x30x6 - Coperchio rimovibile cm 35x32x6 - 2 Fornelletti inox

· Round chafing dish with non-deformable polycarbonate cloche provided with 220 v / 700 w electric resistance composed of: Grill - tank - food seat - hinged and removable lid

· Réchaud rond avec couple en polycarbonate indeformable avec resistance électrique 220 v / 700 w composé de: Base percée - cuve - bac aliments - couvercle à couple et démontable

· Rundes chafing dish mit formbeständiger polycarbonat-haube mit 220 v / 700 w elektrischem widerstand bestehend aus: Siebboden - wanne - lebensmittelbecken

· Hornillo redondo cúpula de polycarbonato indeformable con resistencia eléctrica 220 v / 700 w compuesto por: Base perforada - recipiente - depósito alimentos - tapa articulada y desmontable

Cod. 30595534

cm	h cm	Euro
46x40	21	503,88



Diagramma del mantenimento della temperatura
Temperature maintenance diagram



CHAFING DISH ROTONDO CON CUPOLA IN POLICARBONATO INDEFORMABILE
composto da: Base traforata - Vasca ø cm 49,5 x 10 - Bacinella alimenti ø cm 40 x 7
- Coperchio cupola ø cm 48,5 x 26 - 2 Fornelletti inox

· Round chafing dish with non-deformable polycarbonate cloche composed of: Grill - tank - food seat - hinged and removable lid - heaters

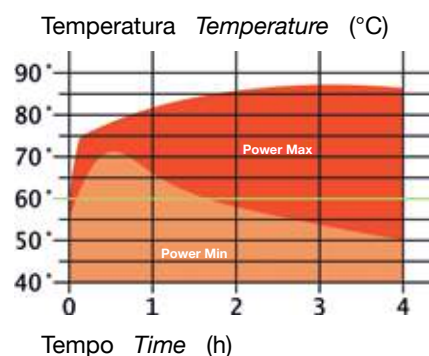
· Réchaud rond avec couple en polyc. indeform. composé de: Base percée - cuve - bac aliments - couvercle articulé et démontable - fourneaux

· Chafing dish rund mit brennpastenbehältern bestehend aus: Siebboden - wanne - lebensmittelbecken - kocher

· Hornillo redondo con cúpula de policarbonato indeformable y stufas compuesto por: Base perforada - recipiente - depósito alimentos - tapa articulada y desmontable - hornillos quemadores

Cod. 30595540

Ø cm	h cm	Euro
49,5	47	369,62

CHAFING DISH ROTONDO CON CUPOLA IN POLICARBONATO CORREDATO
DA RESISTENZA ELETTRICA 220 VOLTS / 700 WATT composto da: Base traforata
- Vasca ø cm 49,5 x 10 - Bacinella alimenti ø cm 40 x 7 - Coperchio cupola ø cm 48,5
x 26 - 2 Fornelletti inox

· Round chafing dish with non-deformable polycarbonate cloche provided with 220 v – 700 w electric resistance composed of: Grill - tank - food seat - hinged and removable lid

· Réchaud rond avec couple en polycarbonate indeformable avec resistance électrique 220 v – 700 w composé de: Base percée - cuve - bac aliments - couvercle à coupole et démontable

· Rundes chafing dish mit formbeständiger polycarbonat-haube mit 220 v – 700 w elektrischem widerstand bestehend aus: Siebboden - wanne -lebensmittelbecken

· Hornillo redondo cúpula de policarbonato indeformable con resistencia eléctrica 220 v – 700 w compuesto por: Base perforada - recipiente - depósito alimentos - tapa articulada y desmontable

Cod. 30595541

Ø cm	h cm	Euro
49,5	47	530,30



Diagramma del mantenimento della temperatura
Temperature maintenance diagram



CHAFING DISH

ZUPPIERA 2 STAZIONI composta da: Base traforata / Bagnomaria Gastronorm - Coperchio Gastronorm con spacco - 2 zuppiere semisferiche Lt 5 - 2 coperchi - 2 fornelli inox

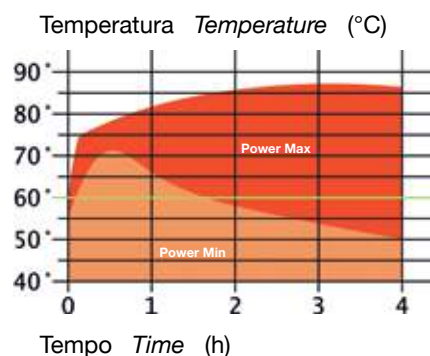
· 2 Soupe stations: Perforated stand, gastronorm bain marie, gastronorm lid, 2 soup bowls, 2 lids, 2 section soup-bowl - 2 heaters

· Soupière a 2 stations: base ajourée cm 56x35x34h - bain-marie gastronorm - couvercle gastronorm avec fente 2 bols semi-sphériques 5 Lt - 2 Couvercles - 2 fourneaux

· Suppenstation 1/1 - suppenstation 1/1 mit brennpastenbehältern: durchbrochene basis cm 56x35x34h, bain-marie deckel mit schlitze - 2 halbkugelige suppenschüsseln l 5 - 2 deckel - 2 kocher

· Sopera 2 staciones: base perforada cm 56x35x34h baño maria gastronomico - tapa con hendidura gastronomica 2 soperas semi esfericas - 2 tapas - 2 hornillos quemadores Cod. 30595556

cm	h cm	Euro
56x35	34	420,16

ZUPPIERA 2 STAZIONI CORREDATA DA RESISTENZA ELETTRICA 220 VOLTS 700 WATT cm 56x35x34 composto da: - Base traforata - Bagnomaria Gastronorm Coperchio Gastronorm con spacco - 2 zuppiere semisferiche Lt 5 - 2 coperchi - 2 fornelli inox

· 2 Soupe stations provided with 220 v – 700 w electric resistance composed of: perforated stand, gastronorm bain marie, gastronorm lid, 2 soup bowls, 2 lids, 2 section soup-bowl

· Soupière a 2 stations avec résistance électrique 220 v – 700 w composée de: base ajourée cm 56x35x34h - bain-marie gastronorm - couvercle gastronorm avec fente - 2 bols semi-sphériques 5 Lt - 2 Couvercles

· Suppenstation 1/1 mit 220 v – 700 w elektrischer heizung bestehend aus: durchbrochener basis cm 56x35x34h, - bain-marie deckel mit schlitze - 2 halbkugeligen suppenschüsseln l 5 - 2 deckeln

· Sopera 2 staciones con resistencia eléctrica 220 v – 700 w compuesta por: base perforada cm 56x35x34h - baño maria gastronomico - tapa con hendidura gastronomica - 2 soperas semi esfericas - 2 Tapas

Cod. 30595563

cm	h cm	Euro
56x35	34	594,58

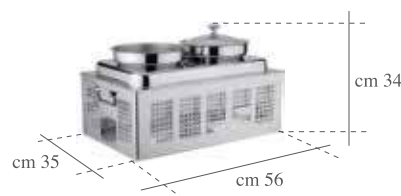
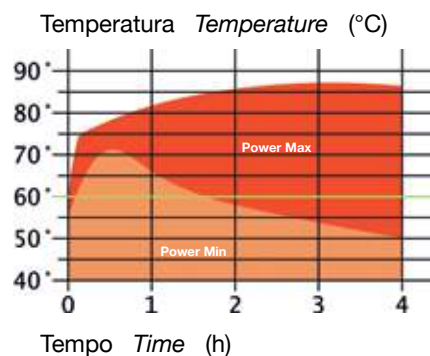

CHAFING DISH GN 1/1 GASTRONORM composto da: Base traforata cm 54x33x19,5h - Bagnomaria Gastronorm cm 51x30,5x11h - Bacinella Gastronorm 1/1 cm 50x29,5x6,5h Coperchio Gastronorm a cupola rettangolare cm 53x32,5x9h rimovibile - 2 fornelli inox

· Chafing dish composed of: Perforated stand 56x35x34 cm - gastronorm - bain marie - gastronorm basin 1/1 - Gastronorm lid 2 heaters

· Chafing dish composé de: Base ajourée cm 56x35x34h - bain-marie gastronorm - bac gastronorm 1/1 - couvercle - gastronorm à cloche rectangulaire - 2 Fourneaux

· Chafing dish 1/1 mit brenn pastenbehältern bestehend aus:

Durchbrochener basis cm 56x35x34 - bain marie gastronorm - deckel - 2 kochern

· Hornillo completo compuesto por: Base perforada cm 56x35x34h - baño maria gastronómico - cubeta gastronómica - tapa gastronómica - Campana rectangular - 2 hornillos quemadores

Cod. 30595555

cm	h cm	Euro
64x40	29	356,72

CHAFING DISH GN 1/1 GASTRONORM CORREDATO DA RESISTENZA ELETTRICA 220 VOLTS 700 WATT composto da: Base traforata cm 54x33x19,5h - Bagnomaria Gastronorm cm 51x30,5x11h - Bacinella Gastronorm 1/1 cm 50x29,5x6,5h - Coperchio Gastronorm a cupola rettangolare cm 53x32,5x9h rimovibile - 2 fornelli inox

· Chafing dish provided with 220 v – 700 w éléctric résistance composed of: perforated stand 56x35x34 cm - gastronorm bain marie -gastronorm basin 1/1gastronorm lid

· Chafing dish avec résistance éléctrique 220 v – 700 w composée de:

base ajourée cm 56x35x34h - bain-marie gastronorm - bac gastronorm 1/1 - couvercle gastronorm à cloche rectangulaire

· Chafing dish 1/1 mit 220 v – 700 w elektrischer heizung widerstand bestehend aus: durchbrochener basis cm 56x35x34 - bain marie gastronorm deckel

· Hornillo completo compuesto par: base perforada baño maria - gastronómico - cubeta gastronómica - tapa gastronómica de campana rectangular

Cod. 30595554

cm	h cm	Euro
64x40	29	541,00



Diagramma del mantenimento della temperatura
Temperature maintenance diagram



GIREVOLI

INOX
18/10

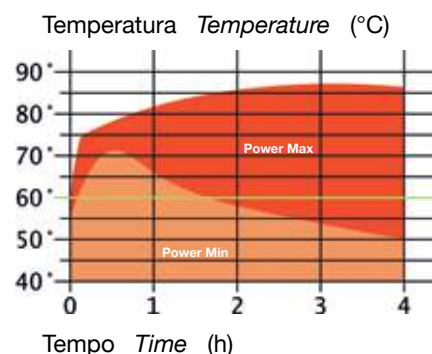
Turnable food-warmer

PAELLERA GIREVOLE composta da: Base con ralla girevole - Anello traforato - Tegame con fondo termodiffusore e coperchio ø cm 50 - 5 candele

· Turnable frying pan for paella consisting of: Tournable plate - Perforated ring - Pan 50 cm with sandwich botton and lid - 5 Candle

· Pêle à paella tournante composée de: Base tournante - Support ajouré - Poêle et fond thermodiffuseur cm 50 et couvercle - 5 Bougies

· Drehbare paellera komplett besteht aus: Fuß mit Löchern - Bain-Marie und Deckel mit Schlitz G/N - Halbkugelige Suppenschüssel Liter 5 mit Deckel - mit 5 Kerze

· Paellera giratoria compuesto de: Base con balanceo giratorio - Anillo perforado, Rustidera con fondo difusor y tapa cm 50 - 5 Bujías

Cod. 50953954

Ø cm	h cm	Euro
50	23	431,76

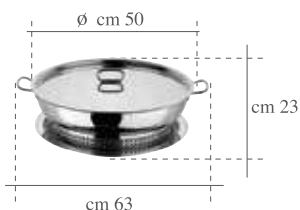

SCALDAVIVANDE GIREVOLE composto da: Base con ralla girevole - Anello traforato, Tegame con fondo termodiffusore e coperchio ø cm 50 - Set porcellana 5 settori con 1 ciotola centrale - 5 candele

· Turnable food-warmer consisting of: Tournable plate, Perforated ring - Pan 50 cm with sandwich botton and lid - 5 sector chinaware with inner bowl - 5 Candles

· Chauffe-plats tournant composée de: Base tournante - Support ajouré, Poêle et fond thermodiffuseur cm 50 et couvercle - Set porcelaine 5 secteurs avec bol intérieur - 5 Bougies

· Rolling center pieze komplett besteht aus: Fuß mit Löchern - Bain-Marie und Deckel mit Schlitz G/N - Halbkugelige Suppenschüssel Liter 5 mit Deckel - mit 5 Kerze - Porzellan Einsatz 6 tlg

· Calienta-alimentos giratorio compuesto de: Base con fondo giratorio - Anillo perforado - Rustidera con fondo difusor y tapa cm 50 - Set porcelana 5 sectores con 1 bol central - 5 Bujías

Cod. 50953953

Ø cm	h cm	Euro
50	24	615,24

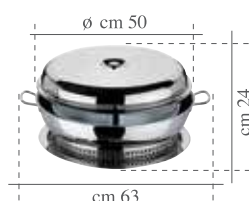

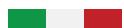

PORTA BROCCHE

Jug holder

PORTA BROCCHE COMPLETO DI 3 BROCCHE Lt 1,5

Jug holder complete with 3 1,5 Lt jugs

Porte-carafes avec 3 carafes 1,5 Lt

Tablett, für 3 krüge à 1,5 Lt

Porta-jarras jarras 1,5 Lt

Cod. 50951A00

Ø cm	h cm	Euro
37	7,2	144,66

PORTABROCCHE

Jug holder - Porte-carafes - Tablett - Porta-jarras

Cod. 50951A0S

Ø cm	Euro
37	48,98



FOTO ESEMPIO
EXAMPLE PHOTO

BROCCA TERMICA INOX 18/10

Pitcher - Cruche

Krug - Lanzador

Cod. 557590..

Lt	Euro
1	29,58
1,5	31,28
2	36,68



Technical informations

ACCIAIO INOX 18/10 - AISI 304 viene fornito esclusivamente dalle principali acciaierie europee.

La sua eccezionale resistenza alla ruggine, la brillantezza e le caratteristiche igieniche soddisfano i requisiti della moderna gastronomia. Esso infatti resiste agli acidi contenuti nei prodotti alimentari, nei detersivi.

L'acciaio Inox 18/10 è antiurto e particolarmente adatto al lavaggio in lavastoviglie.

POLICARBONATO - PC é un polimero di pregio racchiude alcune caratteristiche della plastica, dell'acciaio e del vetro. La trasparenza si avvicina al 90%. La resistenza meccanica alla deformazione ha una elevata resistenza all'urto. L'elevata stabilità dimensionale viene garantita fino ad una temperatura di 130 gradi. In presenza di fiamma è autoestinguente. Non resiste a: soluzioni alcaline, acetone, ammoniaca, benzolo ed alcool metilico. Il materiale è sicuro dal punto di vista fisiologico e può andare a contatto con gli alimenti.

VETRO delle ciotole è per alimenti, infrangibile.

PORCELLANA è per alimenti, non presenta tracce di sostanze dannose, né cessioni di elementi pericolosi.

FAGGIO Il tagliere in faggio lamellare è garantito a norma di legge, è trattato per non assorbire odori e ritenere umidità. Deve essere lavato a mano ed asciugato.

RESISTENZE Sono adatte ad un voltaggio di 220 Volts. Conformi alle norme CEE.

18/10 AISI 304 STAINLESS STEEL is supplied almost exclusively by the main European steelworks. Its exceptional rust resistance, its brilliance and hygienic qualities satisfy the requirements of modern gastronomy; in fact, it resists the acids contained in foodstuffs, detergents and is shockproof. 18/10 steel is dishwasher safe.

POLYCARBONATE - PC is a valuable polymer that has some characteristics from plastics, steel and glass. Its transparency is close to 90%. Its strain strength has a high impact strength. Its high dimensional stability is guaranteed up to a 130-degree temperature. In the presence of flame, it is self-extinguishing. Warning: it does not withstand: alkaline solutions, acetone, ammonia, benzol and methyl alcohol. The material is safe from the physiological point of view and can get in touch with food.

GLASS of bowls is suitable for food usage and is unbreakable.

CHINA is suitable for food usage and does not contain harmful substances or release dangerous elements.

BEECHWOOD The laminar beechwood board complies with the rules in force and is treated not to absorb smells and humidity. It must be hand washed and dried with care.

RESISTANCES Suitable for a 220 Volt In compliance with CEE norm.



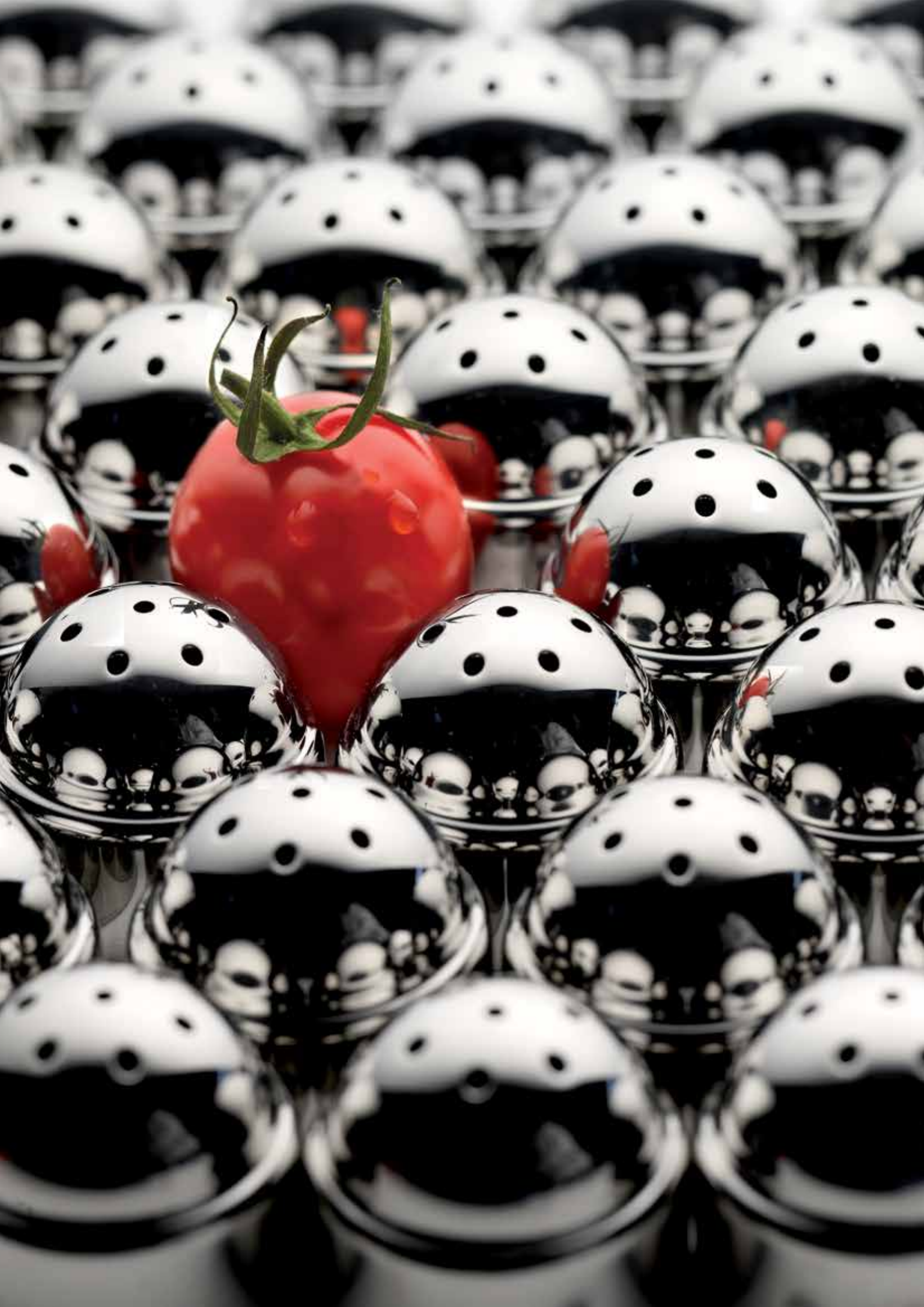

R I C A M B I

S p a r e P a r t s

PiècesDeRechanges

E r s a t z t e i l e

PiezasDeRepuesto



Per alimenti
Suitable for foodstuffs
Apte au contact avec les aliments
Für Lebensmittel
Apto para alimentos



Garantito per lavastoviglie
Dishwasher safe
Inalterable dans lave-vaisselle
Spuelmaschinenfest
Apto para lavavajillas

RICAMBI BUFFET

Spare parts for buffet line

CUPOLA TONDA

Dome lid - Cloche ronde

Rolltop - Campana

Cod. 97150111

cm	Euro
47,5	62,06



FORNELLETTO INOX

Heater - Fourneau

Kocher - Quemadores

Cod. 97200078

cm	h cm	Euro
9-18	6,5	9,36



PORTA BURRO

butter tray - Porte-beurre

Butterschale - Porta-mantequilla

Cod. 50933135

Ø cm	Euro
35	21,00

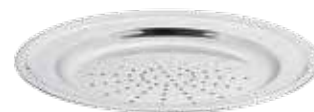

SET PORCELLANA TONDA DA FORNO

Composta da 1 ciotola tonda + 5 settori - 6 sector chinaware with inner bowl -

Porcelaine à secteurs avec bol intérieur - Runder porzellan einsatz - Juego porcelana

Cod. 97150103

Ø cm	h cm	Euro
49	9	179,98

CIOTOLA INTERNA CENTRALE

Central bowl - Coupe intérieure centrale

Innere, zentralschüssel - Cuenco interior central

Cod. 97150104

Ø cm	h cm	Euro
19	9	23,32

SETTORE INTERNO 1/5

Internal sector - Secteur intérieur

Einsatz runde Schale - Medialuna interior

Cod. 97150105

cm	h cm	Euro
28	14	31,72



BUFFET

CONTENITORE ISOLANTE CON COLONNA REFRIGERANTE

Dispenser tank - Récipient isolant

Isolierbehälter - Porte aislante

Cod.	Ø cm	Euro
97150038	16	96,40
97150039	20	112,46



GLACETTE REFRIGERANTE (cm 20x9,8)

Refrigerating brick - Briquette réfrigérante

Kühlakku - Refrigerado

Cod. 97150276

Euro 2,58



BROCCA IN VETRO

Jug - Carafe

Krüge - Jarra

Cod. 97200096

Lt	Euro
1,5	33,60



RICAMBIO CARAFFA TERMICA

Vacuum jug

Cod. 97100110

Euro 9,00



TAGLIERE IN FAGGIO

Beechwood board - Hachoir en hêtre

Küchenbrett aus Buche - Tabla de haya

Cod. 97150115

Euro 38,48



Il tagliere in faggio e' garantito a norma di legge, trattato per non assorbire odori ed umidità. Deve essere lavato a mano ed asciugato.

The beechwood board complies with the rules in force. It has been treated not to absorb smells and humidity. It must be hand-washed and dried with care.

Le hachoir en hêtre est garanti conforme aux dispositions légales, traité pour n'absorber ni odeurs ni humidité. Il est recommandé de le laver à la main et de le sécher soigneusement.

Das Brett entspricht den gesetzlichen Bestimmungen. Es wurde gegen Geruch- bzw Feuchtigkeitsaufnahme behandelt. Handspülen und Abtrocknen.

La tabla de haya está garantizada de conformidad con las leyes, está tratada para no absorber olores ni humedad. Lavarla a mano y secarla cuidadosamente.

BUFFET

RESISTENZA 220 VOLTS 240 WATT CON REGOLATORE
PER DISTRIBUTORE BEVANDE CALDE

220 v 240 w electric resistance for hot drinks dispensers

Résistance électrique 220 v – 240 w pour distributeurs de boissons chaudes

220 v 240 w elektrischer Widerstand für Spender von warmen Getränken

Resistencia eléctrica 220 v – 240 w para distribuidores de bebidas calientes

Cod. 97150245

Euro 229,90

IN ESAURIMENTO / OUT OF STOCK



RESISTENZA 220 VOLTS 700 WATT CON REGOLATORE
PER CHAFING DISH

220 v 700 w electric resistance for chafing dish

Résistance électrique 220 v – 700 w pour chauffe-plat

220 v 700 w elektrischer Widerstand für Chafing dish

Resistencia eléctrica 220 v – 700 w para hornillo

Cod. 97150118

Euro 227,12



RESISTENZA 220 VOLTS 50 WATT CON REGOLATORE
PER VASSOIO BRIOCHES

220 v 50 w electric resistance for heating tray for brioches

Résistance électrique 220 v – 50 w pour plateau chauffant pour viennoiseries

220 v 50 w elektrischer Widerstand für brioches ausgestattet

Resistencia eléctrica 220 v – 50 w para bandeja para bolleria

Cod. 97150770

Euro 202,56



RUBINETTO COMPLETO SMONTABILE INTERAMENTE IN PPL

PPL faucet

Robinet démontable complètement en PPL

Abnehmbarer hahn ganz aus PPL

Grifo desmontable completamente de PPL

Cod. 97150221

Euro 64,68



RICAMBI OLIERE-FORMAGGERE PITAGORA

Spare parts for Pitagora cruet sets and cheese bowls

VETRO OLIERA

Oil / vinegar glass - Burette - Ersatzflasche für essig/öl - Ampolla

Cod. 97200040 **Euro 9,66**



SALVAGOCCIA

Plastic drop-catcher - Protège-goutte

Ausgiesser plastik essig/öl - Impide-gotas

Cod. 97200054 **Euro 1,48**



CAPPUCCIO IN ACCIAIO INOX 18/10 PER VETRO OLIERA

18/10 Cup for oil/vinegar glass - Capuchon en acier 18/10 pour burette

Metallkappe - Capuchón ampolla de acero inoxidable

Cod. 97200056 **Euro 3,36**



VETRO SALE E PEPE

Salt/pepper glass - Salière - Ersatzglas pfeffer/salz - Salero

Cod. 97200045 **Euro 4,74**



CAPPUCCIO IN ACCIAIO INOX 18/10 PER SALINO

18/10 Salt cup for salt/pepper glass - Capuchon pour salière en acier inoxydable

18/10 - Metallkappe salz - Capuchón salero de acero inoxidable

Cod. 97200052 **Euro 3,26**



CAPPUCCIO PEPE IN ACCIAIO INOX 18/10

18/10 Pepper cup for salt/pepper glass - Capuchon pour poivrière en acier

inoxydable 18/10 - Metallkappe pfeffer - Capuchón pimienta de acero inoxidable

Cod. 97200051 **Euro 3,26**



CAPPUCCIO UNIV. INOX 18/10 PER STUZZICADENTI INCARTATI 18/10

Universal toothpicks cup - Capuchon en acier inoxydable 18/10 pour cure-

dents - Universalkäppchen zahnstocher - Capuchón univ. Para palillos limpiadientes en empapelados

Cod. 97200053 **Euro 2,84**



VETRO PER FORMAGGERA

Cheese bowl glass - Verre pour fromagère

Glas für käsedose - Cristal para quesera

Cod. 97200050 **Euro 6,42**



RICAMBI OLIERE BELLA BRA

Spare parts for Bella cruet sets

VETRO PER OLIERA

Oil glass - Burette - Menage - Ampolla

Cod. 97200110 **Euro 3,42**



VETRO PER SALE/PEPE

Vinegar glass - Burette - Menage - Ampolla

Cod. 97200111 **Euro 2,14**



CAPPUCCIO PER AMPOLLE OLIERA

Cup for oil/vinegar glass - Capuchon pour burette

Metallkappe - Capuchón ampolla

Cod. 97200112 **Euro 7,60**



CAPPUCCIO PER SALE E PEPE

Salt cup for salt/pepper glass - Capuchon pour salière

Salzstreuerkappe aus Stahl - Capuchón salero

Cod.97200113 **Euro 3,10**



RICAMBI OLIERE E FORMAGGERE

Spare parts for cruet sets and cheese bowls

VETRO OLIERA

Oil/vinegar glass - Burette - Menage - Ampolla

Cod. 97200060

Mod.	Euro
Nouvelle Cousine / Progetto	6,72



SALVAGOCCIA

Plastic drop-catcher - Protège-goutte - Stöpsel - Protector de gotas

Cod. 97200062

Mod.	Euro
Nouvelle Cousine / Progetto	0,84



CAPPUCCIO 18/10 PER VETRO OLIERA

18/10 Cup for oil/vinegar glass - Capuchon 18/10 pour burette

Kappe für Menage 18/10 - Capuchón ampolla 18/10

Cod. 97200059

Mod.	Euro
Nouvelle Cousine / Progetto	3,06



RICAMBI OLIERE E FORMAGGERE

SALINO

Salt/pepper glass - Salière - Salzstreuer - Salero
Cod. 97200061

Mod.	Euro
Nouvelle Cousine / Progetto	1,80



CAPPUCCIO IN ACCIAIO INOX 18/10 PER SALINO

18/10 Salt cup for salt/pepper glass
Capuchon en acier inoxydable pour salière
Salzstreuerkappe aus Stahl inox
Capuchón salero de acero inoxidable
Cod. 97200058

Mod.	Euro
Nouvelle Cousine / Progetto	2,84



CAPPUCCIO IN ACCIAIO INOX 18/10 PER PEPE/STUZZICADENTI

18/10 Pepper/toothpicks cup for salt/pepper glass
Capuchon en acier inoxydable pour poivrière
Kappe aus Stahl inox für Pfeffer Salz-und Zahnstocher
Capuchón pimienta/palillos de acero inoxidable
Cod. 97200057

Mod.	Euro
Nouvelle Cousine / Progetto	2,84



CAPPUCCIO UNIV. INOX 18/10 PER STUZZICADENTI INCARTATI

18/10 Universal toothpicks cup
Capuchon en acier inoxydable 18/10 pour cure-dents
Universalkäppchen zahnstocher
Capuchón univ. Para palillos limpiadientes en empapelados
Cod. 97200053

Mod.	Euro
Nouvelle Cousine / Progetto	2,84



VETRO PER FORMAGGERA

Cheese bowl glass
Verre pour fromagère
Glas für Käsedose
Cristal para quesera
Cod. 97200035

Mod.	Euro
Nouvelle Cousine / Progetto	2,10



RICAMBI PENT. A PRESSIONE NEW STAR BRA

Spare parts for New Star pressure cooker

COPERCHIO PENTOLA COMPLETO

Lid for pressure cooker - Couvercle complet pour marmite à pression - Deckel komplett für Schnellkochtopf - Tapa para olla a presión completa

Cod.	Ø cm	Euro
30595014	22	61,10
30595015	24	68,28



POMOLO COPERCHIO

Lid knob - Pommeau pour couvercle
Deckelknopf - Pomo tapa
Cod. 971500P1

Euro 8,36



MANIGLIA PENTOLA

Pot handle - Poignée pour marmite
Topfhandgriff - Asa oll
Cod. 97100222

Euro 6,74



VALVOLA SFIATO

Relief valve - Soupape de decharge de la vapeur - Entlüftungsventil - Válvula de alivio
Cod. 971500P4

Euro 9,42



GUARNIZIONE COPERCHIO

Lid rubber-ring - Garniture pour couvercle
Deckeldichtung - Guarnición tapa

Cod.	Ø cm	Euro
971500P6	22	2,36
97150008	24	9,00

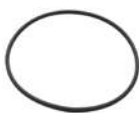

VITE CUSCINETTO PER POMOLO

Bearing with screw - Coussinet avec de Zwischenlegscheibe - Cojinete con tornillo
Cod. 97150001

Euro 5,24



VITE INTERNA PER COPERCHIO

Lid internal screw - Vis intérieure couvercle
Interne Schraube-Deckel - Tornillo interior tapa
Cod. 97150003

Euro 6,74



PREMICOPERCHIO

Lid stopper - Presse couvercle
Deckelhalterung - Prensa tapa

Cod.	Ø cm	Euro
971500P5	22	26,96
97150004	24	26,96



PORTA VALVOLA DI SFIATO

Valve - Soupape
Ventil komplett - Válvula
Cod. 97150000

Euro 5,14



VALVOLA DI SICUREZZA CON GUARNIZIONE

Safety valve - Soupape de surete
Sicherheitsventil - Válvula de seguridad
Cod. 971500P2

Euro 4,72



RICAMBI PADELLE EFFICIENT BRA

Spare parts for Efficient frying pans

MANICO NERO PER PADELLE

Black handle for pans - Poignée noire pour les casseroles
schwarzer Griff für Bratpfanne - Mango negro de sartenes
Cod. 97100240

Ø cm	Euro
30	3,50



MANICO NERO PER PADELLE

Black handle for pans - Poignée noire pour les casseroles
schwarzer Griff für Bratpfanne - Mango negro de sartenes
Cod. 97100241

Ø cm	Euro
22/24/26/28	3,50



MANICO NERO PER PADELLE

Black handle for pans - Poignée noire pour les casseroles
schwarzer Griff für Bratpfanne - Mango negro de sartenes
Cod. 97100242

Ø cm	Euro
16/18/20	2,88



POMOLO COPERCHIO VETRO

Lid knob - Pommeau pour couvercle
Deckelknopf - Pomo tapa
Cod. 97100243

Euro 3,10



DADO SOSTEGNO MANICO

Nut of handle - Perno des manche
Mutter Griff - Boulon de mango
Cod. 97100244

Euro 2,48



CONDIZIONI GENERALI DI VENDITA

General sales conditions

Con il conferimento dell'ordine il Cliente accetta integralmente le condizioni di vendita e di consegna di seguito elencate:

PREZZI L'attuale quotazione a listino si intende per merce resa franco nostro stabilimento. La merce é venduta ai prezzi in Euro in vigore all'atto della spedizione dell'ordine. La ditta si riserva la facoltà di modificare in qualsiasi momento i prezzi di vendita. Per imballo e confezionamento addebito 1%.

CONSEGNA Per giorno di consegna viene inteso quello indicato nella bolla di consegna controfirmata dal corriere. Il termine di consegna, essendo vincolato alle possibilità del momento e potendo variare per motivi indipendenti dalla volontà della ditta, é inteso come approssimativo e non impegnativo. Il mancato rispetto da parte nostra del termine di consegna concordato non dà diritto al Cliente di annullare l'ordine, protrarre il pagamento, richiedere un indennizzo, compenso o penale qualsiasi.

RECLAMI La merce viaggia a rischio e pericolo del destinatario anche nel caso in cui la merce viaggi in porto franco. Il Cliente deve verificare la merce all'atto della consegna. Tutti i reclami riferentesi alla qualità della merce devono essere comunicati a mezzo raccomandata o fax entro otto giorni dal ricevimento della merce pena la decadenza di qualsiasi diritto. Per qualsiasi contestazione é competente esclusivamente il Foro di Brescia.

PAGAMENTO Da convenirsi all'ordine.

La merce rimane di riservato dominio della ditta PINTI INOX fino all'avvenuto pagamento.

Per tutto quanto non previsto esplicitamente si fa riferimento a quanto previsto dal Codice Civile.

Gli articoli esposti nel presente catalogo si intendono a solo titolo informativo e senza alcun impegno da parte della PINTI INOX.

MISURE E CAPACITÀ sono puramente indicative.

La PINTI INOX si riserva il diritto insindacabile di apportare, anche senza preavviso, tutte le modifiche e le migliorie richieste da esigenze commerciali e/o tecniche di qualsiasi natura.

RESA E TRASPORTO In Italia su richiesta:

Area Nord 1,5% del valore della fattura

Area centro 2,5% del valore della fattura

Area Sud 3% del valore della fattura

Isole 4% del valore della fattura

Per ordini inferiori a 1000 € di imponibile saranno addebitati 25 € per gestione imballo.

URGENZE in caso di necessità particolari, è possibile richiedere la spedizione di un ordine nelle 24 ore con corriere espresso priority: se confermato, il costo del servizio è di € 40,00 più eventuali spese di trasporto

Qualora fosse richiesta la sponda idraulica verrà riaddebitato il costo del servizio di euro 50,00 per consegna.

When the order is conferred, the customer will integrally accept the selling and delivery conditions listed herebelow: PRICES the current price list is to be considered ex our factory. The goods are sold with prices in EURO valid at the time of the shipping. We reserve the right to decide about the modification of the current selling prices in every up to moment. For packing and packaging there will be a debit of 1%.

DELIVERY the delivery day is the one indicated in the delivery note countersigned by the courier. The delivery term is approximate and not binding as it is tied up to the current possibilities and may vary because of reasons not related to the company's will. Should we not observe the agreed delivery terms, the customer has not the right to cancel the order, postpone the payment, require any sort of refund, compensation or penalty.

COMPLAINTS the goods are carried at consignee's risk. The customer must verify the goods upon receipt. Any sort of complaint concerning the quantity or the quality of the goods must be sent by registered mail within eight days after the receipt of the goods, or any right for complaining will be lost. Any arbitration or disputes will be governed by the Italian laws.

PAYMENT to be agreed with the order.

Pinti Inox is the sole owner of the goods until the full payment is effected.

For whatever not explicitly mentioned hereabove, please refer to the Civil Code.

The articles shown in the present catalogues have merely an informative function, and do not bind Pinti Inox.

MEASUREMENTS AND CAPACITIES are indicative.

Pinti Inox reserves the unquestionable right to either modify or improve any item-even without notice-because of market and/or technical requirements.

MINIMUM ORDER 1000,00 euros.



ESPOSITORI

D i s p l a y

P r é s e n t o i r

W a n d a u s s t e l l e r

E x p o s i t o r

ESPOSITORI

Display

ESPOSITORE ORANGE SPOT
CON 45 GANCI E RIPIANO
Display with 45 hooks and shelf
Cod. 99900053

largh.	prof.	altez.	Euro
70	50	220	630,00

struttura espositore per Orange Spot
Orange Spot display
99900161
Euro 279,10

ganci per Orange Spot
Orange Spot hooks
99900056
Euro 5,78

modulo portaposate per Orange Spot
(14 nicchie)
cutleries shelf Orange Spot display
99900057
Euro 157,50

ripiano per Orange Spot
Orange Spot shelf
99900160
Euro 91,00



PINTINOX®
made in italy

Astra



espositore Orange Spot con serie Astra
Orange Spot display with Astra kitchentools

99900053 espositore Orange Spot con 45 ganci
Orange Spot display with 45 hooks

PINTINOX®
made in italy



espositore Orange Spot con serie Ellisse
Orange Spot display with Ellisse kitchentools

99900053 espositore Orange Spot con 45 ganci
Orange Spot display with 45 hooks



espositore Orange Spot con coltelli Professional
Orange Spot display with Professional knives

99900053 espositore Orange Spot con 45 ganci
 Orange Spot display with 45 hooks



espositore Orange Spot con serie Molle
Orange Spot display with Tongs

99900053 espositore Orange Spot con 45 ganci
 Orange Spot display with 45 hooks

ESPOSITORI

struttura espositore GDO
GDO display

Cod.	largh.	prof.	altez.	Euro
99900120	66,5	60	220	352,90
99900121	100	60	220	417,90
99900122	133	60	220	460,80



mensola
shelf

Cod.	cm	Euro
99900129	66,5x50	53,90
99900135	100x50	68,00
99900141	133x50	79,00



barra per ganci
bar for hooks

Cod.	cm	Euro
99900144	66,5	29,90
99900145	100	29,90
99900146	133	36,60



ganci (10 pz)
hooks (10 pcs)
99900147

Euro 80,00



porta prezzo (10 pz)
price holder (10 pcs)
99900148

Euro 10,00



ESPOSITORI

BASE ESPOSITORE PALL BOX
 POSATE PER CROWNER
 PERSONALIZZATI (6 nicchie)
 Display - Présentoir
 Wandaussteller - Expositor
 Cod. 99900112

largh.	prof.	altez.	Euro
60	40	200	360,40

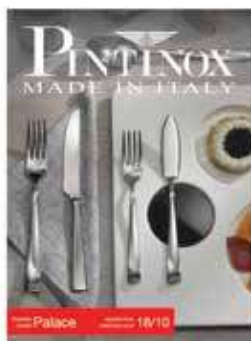

crowner Palace
 Palace crowner
 99900113
Euro 66,00



crowner Privilege
 Privilege crowner
 99900114
Euro 66,00

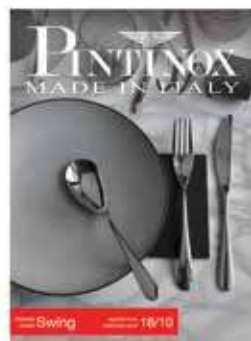

crowner Swing
 Swing crowner
 99900115
Euro 66,00



crowner Maitre
 Maitre crowner
 99900116
Euro 66,00

ESPOSITORI

ESPOSITORE PALL BOX PER PADELLE
 Pall box display for frying pans - Présentoir
 - Wandaussteller - Expositor
 Cod. 99900014

largh.	prof.	altez.	Euro
40	66	136	62,90



ESPOSITORE SENZA GANCI
 Wall display (without hooks) - Présentoir mural (sans crochets)
 Wandaussteller (ohne Haken) - Expositor de pared (sin ganchos)
 Cod. 99900028

lunghezza	prof.	altez.	Euro
100	44	220	471,10

GANCI (50 PZ PER CONFEZIONE)
 Hooks (50 pcs) - Crochets (50 pcs)
 Haken (50 er pack) - Ganchos (50 piezas)
 Cod. 99900032 **Euro 180,84**

RIPIANO PIANO (3 PZ PER CONFEZIONE)
 Flat shelf (3 pcs) - Rayon horizontal (3 pcs)
 Flachboden (3 er pack) - Estante plano (3 piezas)
 Cod. 99900033

cm	Euro
50	180,84



ESPOSITORI

ESPOSITORE CURVO

Bent display (without shelves) - Présentoir courbé (sans rayons)

Bogenförmiger Aussteller (ohne Böden) - Expositor curvado (sin estantes)

Cod. 99900027

lungh.	prof.	altez.	Euro
100	44	220	516,38



GANCI (50 PZ PER CONFEZIONE)

Hooks (50 pcs) - Crochets (50 pcs)

Haken (50 er pack) - Ganchos (50 piezas)

Cod. 99900032 **Euro 180,84**

RIPIANO PIANO (3 PZ PER CONFEZIONE)

Flat shelf (3 pcs) - Rayon horizontal (3 pcs)

Flachboden (3 er pack) - Estante plano (3 piezas)

Cod. 99900036

cm	Euro
30	180,84

PORTAQUATERNA LEGNO (15 PZ PER CONFEZIONE)

4 pz wooden display (15 pcs) - Présentoir en bois 4 pcs (15 pcs)

Holzdisplay 4 Tlg (15 er pack) - Expositor 4 piezas (15 piezas)

Cod. 99900035

lungh.	prof.	altez.	Euro
18,5	15	27	123,18



PORTAQUATERNA PINTINOX

Display 4 pcs - Présentoir 4 pcs

Display 4 Tlg - Expositor 4 piezas

Cod. 92903052

lungh.	prof.	altez.	Euro
15,5	14	10,2	12,50



NEW







SEZIONE ESPLICATIVA

Technical Information

Information Technique

Technische Informationen

Información Técnica

LA COSTRUZIONE DELLE POSATE

Cutlery manufacturing process



1
Lamiera da coils
Coils sheet



2
Tranciatura
Blanking



3
Laminazione
Rolling



4
Ritrancio tazza
Bowl cutting



5
Coniatura
Embossing



6
Lucidatura prodotto
finito
Polishing finished
product

LA COSTRUZIONE DEI COLTELLI

Knife manufacturing process

a) Coltello monoblocco con lama temperata *Solid knife with hardened blade*



1 AISI 420
Barra d'acciaio
Steel bar

2
Partic. fucinato
Forged piece

3
Partic.
ritranciato
Blanked piece

4
Partic. molato
Ground piece

5
Prodotto finito
Finished product

b) Coltello con manico cavo e lama fucinata *Hollow handle knife with forged blade*



1
Lama fucinata
Forged blade

2
Manico cavo
Hollow handle

L'ACCIAIO

The steel

Acciaio inox 18/10

Acciaio 18% cromo

Le diverse qualità di acciai per posate. L'acciaio inox 18/10 AISI 304 e inox 18% cromo AISI 430, vengono forniti esclusivamente dalle principali acciaierie europee. La loro eccezionale resistenza alla ruggine, la brillantezza e le caratteristiche igieniche soddisfano i requisiti della moderna gastronomia; essi infatti resistono agli acidi contenuti nei generi alimentari e nei detersivi ed è antiurto. Gli acciai AISI 304 e 430 sono particolarmente adatti al lavaggio in lavastoviglie.

18/10 stainless steels

18% chrome stainless steels

The different steel grade used for cutlery. Pinti 18/10 AISI 304 and 18% CHROME AISI 430 stainless steel are supplied almost exclusively by the main European steelworks. Their exceptional rust resistance, their brilliance and hygienic qualities satisfy the requirements of modern gastronomy; in fact, they resist the acids contained in foodstuffs, detergents and they are shockproof. 18/10 and 18% chrome are dishwasher safe.



USO E MANUTENZIONE

Use and care advise

Inossidabilità dell'acciaio usato per coltelli e lame.

In ottemperanza alla legge n° 126 del 10/04/91 "Norme per l'informazione del consumatore" si informano gli utilizzatori di lame e coltelleria circa l'uso corretto del prodotto per evitare fenomeni corrosivi.

- Lavare le lame immediatamente dopo l'uso.
- Utilizzare detergenti neutri o debolmente alcalini.
- Evitare di strofinare lame e coltelli con:
 - a) prodotti abrasivi soprattutto se contenenti cloro.
 - b) pagliette metalliche o sintetiche.
- Non impiegare per il lavaggio ipocloriti (candeggina), né detergenti contenenti cloro o cloruri liberi.
- Asciugare subito dopo il lavaggio con panni morbidi e assorbenti.
- L'asciugatura in lavastoviglie non è in genere sufficiente ad evitare rischi di corrosione, è pertanto necessario effettuare una accurata asciugatura a mano immediatamente dopo il ciclo di lavaggio. Le precauzioni succitate sono indispensabili per evitare danni irreparabili a lame e coltelli.

Rust-proof characteristics of steel used to make knives and blades.

In compliance with the Law no. 126 of 10/04/1991 "Information to Consumer", we hereby advise users of blades and knives on proper use of these products to prevent their rusting.

- *Wash blades immediately after use.*
- *Use neutral or slightly alkaline detergents.*
- *Do not rub blades and knives with:*
 - a) *abrasive products (mainly those containing chlorine)*
 - b) *metal or synthetic wools.*
- *Do not wash with hypochlorites (bleach) or detergents containing chlorine or free chlorides.*
- *Dry immediately after washing with a soft or absorbing cloth.*
- *Generally, drying in dish-washers does not prevent rusting; therefore, dry manually immediately after washing in dish-washers. Strictly follow these advices to prevent blades and knives from being irreparably damaged.*



L'ANTIADERENTE

Non-stick coating

Una sicurezza firmata Teflon

Il più importante produttore mondiale che ne garantisce l'assoluta qualità. Gli strumenti cottura Pintinox BRA dotati di rivestimenti antiaderenti DuPont sono totalmente sicuri per gli usi in cucina. La loro sicurezza è stata confermata dalla FDA americana (Food & Drug Administration) e dai severi test effettuati presso i laboratori DuPont, nonché dall'uso quotidiano che per più di quarant'anni ne hanno fatto milioni di consumatori in tutto il mondo.

Per maggiori informazioni visitare il sito web:

www.teflon.com

Safety signed by Teflon

The most important worldwide manufacturer guarantees its quality. The cookware by Pintinox BRA with DuPont non-sticks are totally safe for kitchen use. Their safety has been certified by the American FDA (Food & Drug Administration) and by rigorous tests made at DuPont laboratories as well as the daily use of millions of consumers worldwide for more than forty years.

For more information:

www.teflon.com



SBAR / Test di abrasione con carta vetrata

Per stabilire la durata di una superficie antiaderente si appoggia un pezzo di carta vetrata con un peso di 1,5 o 4,5 Kg e la si muove avanti e indietro meccanicamente. Ogni 250 cicli si sostituisce la carta vetrata. Quando il limite di usura del rivestimento antiaderente è raggiunto il test viene interrotto e si esamina la superficie di cottura.

SBAR / Abrasive test with sandpaper - SBAR

To determine the duration of a non-stick surface a piece of sandpaper is put on the surface with a 1.5 or 4.5 kg weight over it and mechanically moved forward and backward. The sandpaper is replaced every 250 cycles. The test stops when the wear limit of the non-stick coating is reached and the cooking surface is examined.

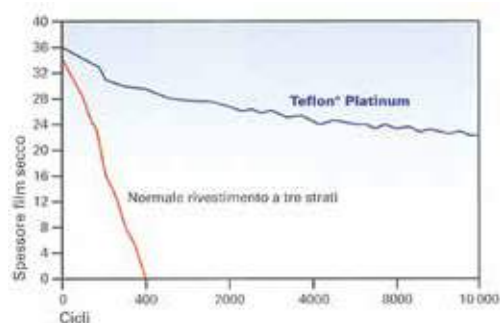

Indice dei cicli di durata con un peso di 1,5 Kg
Length of cycle indicator with a 1.5 kg weight



Test di abrasione con carta vetrata a 4,5 o 1,5 Kg
Abrasion test with sandpaper with 4.5 or 1.5 kg

L'INDICE DI PRESTAZIONE

Performance index

MTP (zampa di Tigre) Questa macchina è stata creata per valutare la resistenza all'abrasione dei rivestimenti antiaderenti e rappresenta una simulazione fortemente accelerata delle condizioni di cottura la "zampa" è stata messa a punto in modo da contenere tre ricariche per penna a sfera in carburo tungsteno che, in condizione di pressione controllata e di riscaldamento a 200°C della padella tracciano solchi costantemente ripetuti sulla superficie di cottura. Quando i danni al rivestimento raggiungono un livello definito si interrompe il test e si misura la superficie.

MTP (Tiger's paw) This machine has been designed to calculate the resistance to abrasion of non-stick coatings and also represents an accelerated simulation of cooking conditions. The "paw" contains three refills for ball point pens made of tungsten carbide which, under a pressure-controlled condition and at 200°C mark the frying-pan cooking surface with constant grooves. When the coating is damaged to a given level the test is stopped and the surface is measured.

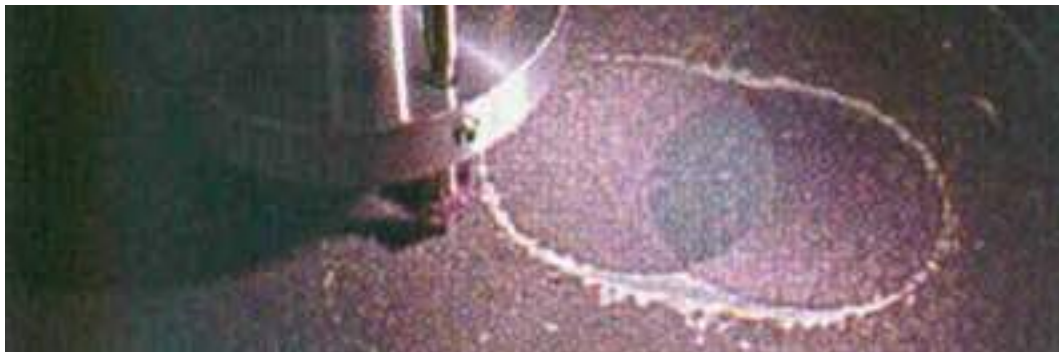

Strumenti: "zampa" con penna a sfera in carburo di tungsteno.
Abrasion measured after 180 minutes.



Normale rivestimento a tre mani - Indice di resistenza all'abrasione = 5 misurata dopo 90 minuti.
Traditional three layer coating - Abrasion resistance index = 5 measured after 90 minutes.

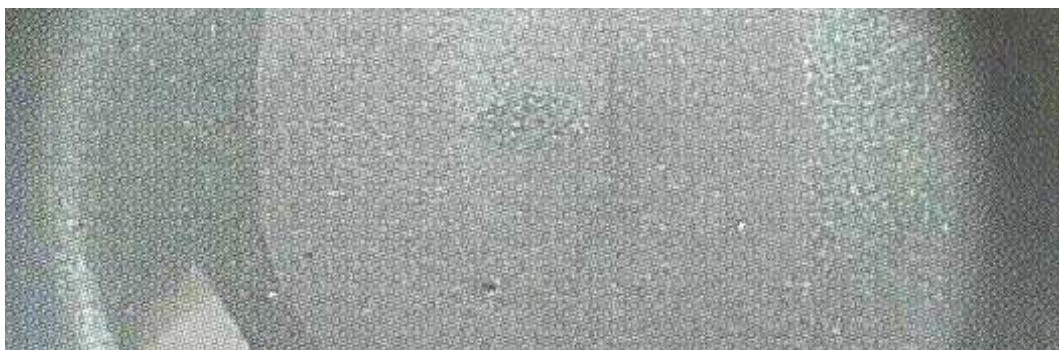

Teflon Platinum - Indice di resistenza all'abrasione = 9 misurata dopo 180 minuti
Teflon Platinum - Instruments: "paw" with tungsten carbide ball point pen resistance index = 9

TEFLON BY DUPONT

Teflon by DuPont

CAMUT - Dispositivo di collaudo con utensili metallici assistito da computer Si tratta di un'attrezzatura di collaudo automatizzata, studiata per valutare la resistenza all'abrasione e ai graffi. La padella viene riscaldata e sottoposta all'azione aggressiva di quattro differenti utensili metallici: coltello, forchetta, spatola e frusta in filo metallico, montati su una testa rotante che si sposta in tutte le direzioni sulla superficie di cottura. Dopo un tempo misurato, si valutano le prestazioni del rivestimento antiaderente in base a una scala predeterminata da 1 a 10. 10 corrisponde ad una padella nuova.

CAMUT - Computer-aided test device with metal utensils This is an automatic test equipment used to evaluate the resistance to abrasion and scratching. The frying-pan is heated and submitted to the aggressive action of four different metal utensils: knife, fork, spatula and metal wire whisk fit on a rotary head that moves in all directions on the cooking surface. After a measured time, the performance of the non-stick coating are checked according to the pre-determined scale from 1 to 10 where 10 corresponds to a new frying-pan.

Indice di prestazione su scala predeterminata

Performance index on a pre-determined scale



Strumenti: forchetta, coltello, spatula, frusta in filo metallico.
Utensils: fork, knife, spatula, metal-wire whisk.



Normale rivestimento a tre mani indice di resistenza ai graffi = 5.
Three-layer traditional coating; index of resistance to scratching: 5.



Teflon® Platinum indice di resistenza ai graffi 7-8.
Teflon® Platinum, index of resistance to scratching: 7-8.

MANUTENZIONE DEL TEFLON

Teflon care advise



Lavare la padella nuova, per pulire è sufficiente acqua calda e detersivo.
Clean the new frying-pan, clean with hot water and detergent.



Adatta al lavaggio in lavastoviglie
Can be washed in dish-washer



Permette di cucinare anche senza grassi
No-fat cooking



Detersivi e pagliette abrasivi possono essere usati solo se l'etichetta ne indica la compatibilità con i rivestimenti antiaderenti in Teflon®.
Detergents or abrasive steel wools can be used only if the label indicates they are compatible with Teflon® non-stick coatings.



Prima dell'uso condizionare con olio.
Brush with oil before use.



Evitare le temperature estreme durante la cottura (non superate i 260°C).
Avoid extreme temperatures during cooking (do not exceed 260°C).



Può essere usata nel microonde, fate attenzione che il materiale di base della padella sia idoneo.
Can be used in micro-wave ovens, make sure the frying pan base material is suitable for it.



I marchi dei rivestimenti antiaderenti più avanzati tecnologicamente come Teflon Platinum e Autograph permettendo anche l'utilizzo di utensili metallici.
The most technologically advanced trademarks of non-stick coatings such as Teflon Platinum and Autograph can also be used with metal utensils.

LA GAMMA TEFLON

The teflon types

Teflon Select

Con caratteristiche di maggiore durata, è il rivestimento destinato ad un uso ultra-intensivo. Prevede l'applicazione di un triplo strato, rinforzato con uno spessore minimo di 35 micron e offre una antiaderenza eccezionale.

- strato superiore
- strato intermedio rinforzato
- strato di fondo rinforzato

Teflon Select

With its longer life, this coating is suitable for an intensive use. It consists of a three-layer coating with a 35 micron thick minimum reinforcement that guarantees exceptional non-stick characteristics.

- upper layer
- intermediate reinforced layer
- lower reinforced layer



Teflon Platinum

È il nostro rivestimento antiaderente più resistente ai graffi e all'abrasione finora realizzato: il primo in grado di resistere anche all'azione dei normali utensili metallici e delle pagliette abrasive. Applicato in tre strati, con uno spessore minimo di 40 micron, contiene microscopiche particelle minerali particolarmente dure con un substrato minimo di 4 mm. Gli utensili metallici scivolano su queste particelle senza danneggiare la superficie in Teflon in cui sono inserite, salvaguardandone così le proprietà di antiaderenza.

- strato superiore
- strato intermedio rinforzato
- strato di fondo con minerale duro

Teflon Platinum

This is our scratching and abrasion most resistant coating, the first that can resist to the abrasive action of metal utensils and steel wool. Made of three layers with a minimum thickness of 40 microns, it contains particularly hard microscopic mineral particles with a minimum 4 mm substrate. The metal utensils slip on these particles with no damage for the Teflon surface where they are contained and the non-stick characteristics are so preserved.

- upper layer
- intermediate reinforced layer
- lower layer with hard mineral



Teflon Platinum PLUS

Con caratteristiche identiche al rivestimento Teflon Platinum viene impiegato solo su supporti in metallo duro, con uno spessore minimo di 40 micron. Substrato di 4 mm.

- strato superiore
- strato intermedio rinforzato
- strato di fondo con minerale duro
- supporto in metallo duro

Teflon Platinum PLUS

With the same characteristics of the Teflon coating, this is used only on hard metal supports with 40 mm minimum thickness and 4 mm substrate.

- upper layer*
- intermediate reinforced layer*
- lower layer with hard mineral*
- hard metal support*



STONE WASHED

	LEONARDO 050200..	VITTORIALE 164200..	BAGUETTE 083200..	SETTECENTO 205400..	PALACE 169200..	CASALI 210200..	STRESA 032400..
01	€ 4,48	€ 5,00	€ 4,48	€ 3,86	€ 3,54	€ 3,54	€ 2,30
02	€ 4,48	€ 5,00	€ 4,48	€ 3,86	€ 3,54	€ 3,54	€ 2,30
03	€ 6,92	€ 7,46	€ 6,92	€ 6,26	€ 5,94	€ 5,62	€ 4,52
L3	-	-	-	-	-	-	€ 3,12
04	€ 4,38	€ 4,90	€ 4,38	€ 3,74	€ 3,54	€ 3,54	€ 2,30
05	€ 4,38	€ 4,90	€ 4,38	€ 3,74	€ 3,54	€ 3,54	€ 2,30
06	€ 6,80	€ 7,34	€ 6,80	€ 6,16	€ 5,94	€ 5,62	€ 4,42
07	€ 2,60	€ 2,70	€ 2,60	€ 2,30	€ 2,30	€ 2,18	€ 1,48
08	€ 2,60	€ 2,70	€ 2,60	€ 2,30	€ 2,30	€ 2,18	€ 1,48
10	€ 17,00	€ 17,00	€ 17,00	€ 16,18	€ 18,36	€ 16,18	€ 13,46
11	€ 7,84	€ 8,38	€ 7,84	€ 7,02	€ 7,44	€ 7,44	€ 5,86
12	€ 7,84	€ 8,38	€ 7,84	€ 7,02	€ 7,44	€ 7,44	€ 5,86
17	€ 3,44	€ 3,44	€ 3,44	€ 2,60	€ 2,60	€ 2,60	€ 1,68
20	€ 11,36	€ 11,36	€ 11,36	€ 10,80	€ 10,80	€ 10,80	€ 6,78
39	€ 4,26	€ 4,90	€ 4,26	€ 3,64	€ 3,54	€ 3,44	€ 2,20
67	€ 6,92	-	€ 6,92	-	€ 5,94	-	€ 4,52



TXT

	SETTECENTO 205300..	PALACE 169300..	CASALI 210300..
01	€ 6,26	€ 5,94	€ 4,84
02	€ 6,26	€ 5,94	€ 4,84
03	€ 10,16	€ 9,84	€ 7,82
CC	€ 14,92	€ 14,92	-
04	€ 6,14	€ 5,94	€ 484
05	€ 6,14	€ 5,94	€ 4,84
06	€ 10,06	€ 9,84	€ 7,82
CD	€ 14,82	€ 14,82	€ 13,12
07	€ 4,20	€ 4,20	€ 3,28
08	€ 4,20	€ 4,20	€ 3,28
10	€ 20,98	€ 23,16	€ 18,78
11	€ 11,82	€ 12,24	€ 10,04
12	€ 11,82	€ 12,24	€ 10,04
17	€ 4,50	€ 4,50	€ 3,70
20	€ 15,60	€ 15,60	€ 13,40
39	€ 6,04	€ 5,94	€ 4,74



ALCHIMIQUE GOLD

	SETTECENTO OJA400..	CASALI OYA200..	VITTORIALE OVA200..	BAGUETTE OWA200.. <i>on demand</i>	PALACE OZA200.. <i>on demand</i>
01	€ 9,16	€ 8,84	€ 10,30	€ 9,78	€ 8,84
02	€ 9,16	€ 8,84	€ 10,30	€ 9,78	€ 8,84
03	€ 11,78	€ 11,12	€ 12,96	€ 12,42	€ 11,46
04	€ 9,06	€ 8,84	€ 10,20	€ 9,68	€ 8,84
05	€ 9,06	€ 8,84	€ 10,20	€ 9,68	€ 8,84
06	€ 11,66	€ 11,12	€ 12,86	€ 12,32	€ 11,46
07	€ 6,76	€ 6,66	€ 7,18	€ 7,08	€ 6,76
08	€ 6,76	€ 6,66	€ 7,18	€ 7,08	€ 6,76
10	€ 39,28	€ 39,28	€ 40,08	€ 40,08	€ 41,44
11	€ 16,90	€ 17,32	€ 18,26	€ 17,72	€ 17,32
12	€ 16,90	€ 17,32	€ 18,26	€ 17,72	€ 17,32
17	€ 7,08	€ 7,08	€ 7,90	€ 7,90	€ 7,08
20	€ 26,40	€ 26,40	€ 26,96	€ 26,96	€ 26,40
39	€ 8,94	€ 8,74	€ 10,20	€ 9,58	€ 8,84
67	-	-	-	€ 12,42	€ 11,46



ALCHIMIQUE BRONZE

	SETTECENTO 0JB400..	CASALI 0YB200..	BAGUETTE 0WB200..	VITTORIALE 0VB200.. <i>on demand</i>	PALACE 0ZB200.. <i>on demand</i>
01	€ 12,38	€ 12,06	€ 13,00	€ 13,52	€ 12,06
02	€ 12,38	€ 12,06	€ 13,00	€ 13,52	€ 12,06
03	€ 15,12	€ 14,48	€ 15,78	€ 16,32	€ 14,80
04	€ 12,38	€ 12,06	€ 12,90	€ 13,42	€ 12,06
05	€ 12,38	€ 12,06	€ 12,90	€ 13,42	€ 12,06
06	€ 15,00	€ 14,48	€ 15,66	€ 16,20	€ 14,80
07	€ 8,12	€ 8,02	€ 8,42	€ 8,54	€ 8,12
08	€ 8,12	€ 8,02	€ 8,42	€ 8,54	€ 8,12
10	€ 42,18	€ 42,18	€ 43,00	€ 43,00	€ 44,36
11	€ 19,50	€ 19,92	€ 20,32	€ 20,86	€ 19,92
12	€ 19,50	€ 19,92	€ 20,32	€ 20,86	€ 19,92
17	€ 8,42	€ 8,42	€ 9,26	€ 9,26	€ 8,42
20	€ 27,96	€ 27,88	€ 28,52	€ 28,52	€ 27,96
39	€ 12,18	€ 11,96	€ 12,80	€ 13,42	€ 12,06
67	-	-	€ 15,78	-	€ 14,80



ALCHIMIQUE TITANIUM

	SETTECENTO 0JC400..	CASALI 0YC200..	PALACE 0ZC200..	VITTORIALE 0VB200.. <i>on demand</i>	BAGUETTE 0WC200.. <i>on demand</i>
01	€ 12,38	€ 12,06	€ 12,06	€ 13,52	€ 13,00
02	€ 12,38	€ 12,06	€ 12,06	€ 13,52	€ 13,00
03	€ 15,12	€ 14,48	€ 14,80	€ 16,32	€ 15,78
04	€ 12,38	€ 12,06	€ 12,06	€ 13,42	€ 12,90
05	€ 12,38	€ 12,06	€ 12,06	€ 13,42	€ 12,90
06	€ 15,00	€ 14,48	€ 14,80	€ 16,20	€ 15,66
07	€ 8,12	€ 8,02	€ 8,12	€ 8,54	€ 8,42
08	€ 8,12	€ 8,02	€ 8,12	€ 8,54	€ 8,42
10	€ 42,18	€ 42,18	€ 44,36	€ 43,00	€ 43,00
11	€ 19,50	€ 19,92	€ 19,92	€ 20,86	€ 20,32
12	€ 19,50	€ 19,92	€ 19,92	€ 20,86	€ 20,32
17	€ 8,42	€ 8,42	€ 8,42	€ 9,26	€ 9,26
20	€ 27,96	€ 27,88	€ 27,96	€ 28,52	€ 28,52
39	€ 12,18	€ 11,96	€ 12,06	€ 13,42	€ 12,80
67	-	-	€ 14,80	-	€ 15,78



TREASURE GOLD

	SETTECENTO 08A000..	BAGUETTE 06A000..	SYNTHESIS 15A000..	OLIVIA 14A000..
01	€ 8,42	€ 8,94	€ 8,02	€ 9,16
02	€ 8,42	€ 8,94	€ 8,02	€ 9,16
03	€ 10,82	€ 11,46	€ 10,48	€ 11,78
04	€ 8,32	€ 8,94	€ 8,02	€ 9,16
05	€ 8,32	€ 8,94	€ 8,02	€ 9,16
06	€ 10,72	€ 11,26	€ 10,48	€ 11,78
07	€ 6,08	€ 6,38	€ 6,04	€ 6,66
08	€ 5,58	€ 5,78	€ 5,54	€ 6,16
17	€ 7,18	€ 8,02	€ 7,18	€ 8,22



TREASURE BRONZE

	SETTECENTO 08B000..	BAGUETTE 06B000..	SYNTHESIS 15B000..	OLIVIA 14B000..
01	€ 11,52	€ 12,04	€ 11,24	€ 12,38
02	€ 11,52	€ 12,04	€ 11,24	€ 12,38
03	€ 13,92	€ 14,56	€ 13,82	€ 15,12
04	€ 11,42	€ 12,04	€ 11,24	€ 12,38
05	€ 11,42	€ 12,04	€ 11,24	€ 12,38
06	€ 13,82	€ 14,36	€ 13,82	€ 15,12
07	€ 7,48	€ 7,78	€ 7,50	€ 8,12
08	€ 7,48	€ 7,68	€ 7,50	€ 8,12
17	€ 10,28	€ 11,12	€ 10,40	€ 11,44



TREASURE TITANIUM

	SETTECENTO 08C000..	BAGUETTE 06C000..	SYNTHESIS 15C000..	OLIVIA 14C000..
01	€ 11,52	€ 12,04	€ 11,24	€ 12,38
02	€ 11,52	€ 12,04	€ 11,24	€ 12,38
03	€ 13,92	€ 14,56	€ 13,82	€ 15,12
04	€ 11,42	€ 12,04	€ 11,24	€ 12,38
05	€ 11,42	€ 12,04	€ 11,24	€ 12,38
06	€ 13,82	€ 14,36	€ 13,82	€ 15,12
07	€ 7,48	€ 7,78	€ 7,50	€ 8,12
08	€ 7,48	€ 7,68	€ 7,50	€ 8,12
17	€ 10,28	€ 11,12	€ 10,40	€ 11,44



TREASURE TOTAL BLACK

SETTECENTO
1AD000..

01	€ 8,12
02	€ 8,12
03	€ 10,52
04	€ 6,22
05	€ 6,22
06	€ 8,62
07	€ 4,18
08	€ 3,98
17	€ 4,38



TREASURE INFINITO

	GOLD 19A000..	BRONZE 19B000..	TITANIUM 19C000..	TOTAL BLACK 19D000..
01	€ 9,16	€ 12,26	€ 12,26	€ 8,80
02	€ 9,16	€ 12,26	€ 12,26	€ 8,80
03	€ 10,40	€ 13,50	€ 13,50	€ 8,90
04	€ 9,06	€ 12,16	€ 12,16	€ 6,34
05	€ 9,06	€ 13,20	€ 13,20	€ 6,34
06	€ 10,10	€ 13,20	€ 13,20	€ 7,86
07	€ 7,26	€ 8,66	€ 8,66	€ 5,24
08	€ 6,66	€ 8,56	€ 8,56	€ 4,92
17	€ 8,16	€ 11,26	€ 11,26	€ 5,24
25	€ 9,16	€ 12,26	€ 12,26	€ 6,92
38	€ 8,90	€ 12,00	€ 12,00	€ 6,44
39	€ 8,86	€ 11,96	€ 11,96	€ 7,08
FB	€ 8,86	€ 11,96	€ 11,96	€ 6,40
28	€ 9,10	€ 12,20	€ 12,20	€ 7,22
29	€ 9,10	€ 12,20	€ 12,20	€ 7,22



MYSTIQUE

	PALLADIUM 059600..	OLIVIA 049600..	SWING 088600..	MILLENNIUM 227600..	BERNINI 206600..	SYNTHESIS 203600..	STRESA 032600..	TUBE 112600..	DINNER R04600..
01	€ 4,84	€ 4,84	€ 4,84	€ 4,96	€ 4,12	€ 3,70	€ 2,76	€ 2,04	€ 2,10
02	€ 4,84	€ 4,84	€ 4,84	€ 4,96	€ 4,12	€ 3,70	€ 2,76	€ 2,04	€ 2,10
03	€ 7,36	€ 7,36	€ 7,36	€ 7,36	€ 6,40	€ 5,96	€ 4,88	€ 3,92	-
L3	-	-	-	-	-	-	-	-	€ 2,58
04	€ 4,74	€ 4,74	€ 4,74	€ 4,86	€ 4,02	€ 3,60	€ 2,66	-	-
05	€ 4,74	€ 4,74	€ 4,74	€ 4,86	€ 4,02	€ 3,60	€ 2,66	-	-
06	€ 7,06	€ 7,06	€ 7,06	€ 7,06	€ 6,30	€ 5,86	€ 4,68	-	-
07	€ 3,00	€ 3,10	€ 3,00	€ 3,32	€ 2,70	€ 2,48	€ 1,86	€ 1,54	€ 1,54
08	€ 2,90	€ 3,10	€ 2,90	€ 3,10	€ 2,70	€ 2,48	€ 1,86	€ 1,54	-
10	€ 16,80	€ 18,78	€ 16,80	€ 16,80	€ 15,96	€ 16,80	€ 13,16	-	-
11	€ 8,28	€ 9,10	€ 8,28	€ 8,80	€ 7,44	€ 7,44	€ 6,20	-	-
12	€ 8,28	€ 9,10	€ 8,28	€ 8,80	€ 7,44	€ 7,44	€ 6,20	-	-
17	€ 3,74	€ 3,74	€ 3,74	€ 3,2	€ 2,90	€ 2,70	€ 1,96	€ 1,76	-
20	€ 11,92	€ 11,92	€ 11,92	€ 12,74	€ 11,40	€ 8,58	€ 7,12	-	-
39	€ 4,74	€ 4,84	-	€ 4,84	-	-	€ 2,66	-	-



TREASURE 50/50 BLACK

	BRAMANTE 1CE000..	ELLADE 1DF000..	HERMITAGE 1FF000..
01	15,62	15,40	13,10
02	15,62	15,40	13,10
03	15,62	15,82	11,28
04	14,76	14,58	-
05	14,76	14,58	12,16
06	14,94	15,30	10,42
07	12,90	12,74	9,26
08	12,70	15,52	9,14
17	13,82	13,46	9,56
39	14,98	14,88	12,16



TREASURE TXT

	SETTECENTO GOLD 2AA000..	PALACE TITANIUM 2BC000..
01	10,82	13,62
02	10,82	13,62
03	14,72	17,50
04	10,72	13,62
05	10,72	13,62
06	14,62	17,50
07	7,98	9,38
08	7,48	9,38
17	9,08	12,18
39	10,62	13,62







I N D I C E

l n d e x

l n d e x

Inhaltsverzeichnis

í n d i c e

POSATE

Flatware

Aida	96	Hotel	88	Solaris	77
America	87	Infinito	36	Spaten	33
Australia	97	Ischia	92	Stile	56
Baguette	44	Leonardo	52	Stresa	102
Bernini	63	Liberty	64	Superamerica	83
Beta	90	Maitre	84	Superga	103
Bramante	26	Millemium	54	Swing	40
Brasilia	89	Octavia	30	Synthesis	74
Bristol	86	Olivia	42	Tecna	38
Byron	46	Pagaia	85	Tema	93
Cambridge	104	Palace	66	Tie	76
Carlton	58	Palladium	48	Touring	109
Casali	68	Pitagora	50	Trend	72
Concept	34	Privilege	29	Trumpet	62
Dolphin	98	Punto	106	Tube	110
Eco Baguette	108	Ritz	55	Uno	100
Ellade	27	Roma	80	Valencia	99
Euclide	49	Romanino	60	Vittoriale	32
Excelsior	70	Sabrina	82	Wave	94
Expo	73	Savoy	69		
Filet	81	Settecento	59		
Gamma	91	Sirio	78		
Hermitage	28	Snake	107		

GLI SPECIALI - CONFEZIONI

Special flatware - packaging

Box 11+1	116	Espositori	378
Box 11+1 Trasparente	117	Etichetta Singola	120
Box 5+1	119	Forchetta Pizza	134
Chiave	114	Gli Esclusivi	123
Cartelle	118	Griglia Posate Box 11+1	116
Coltelli Bistecca	132	Griglia Posate Box 11+1 Trasparente	117
Coltelli Pizza	134	Griglia Posate C/Chiave	114
Coltello Manico Vuoto	130	Griglia Posate C/Cravatta	113
Cravatta	113	Valve	120

PRODOTTI IN ORDINE ALFABETICO

acciaino	141	coltello per filettare	137
appendino magnetico	141-293	coltello prosciutto	138
bacinella pasticceria	346	coltello salmone	138
bacinellesse gastronomiche	229-259	coltello servire	144
bacinellesse gn con maniglie	238	coltello spelucchino	140-142
bacinellesse gastronomiche forate	235-250	coltello verdura	140-142
bagnomaria	262	cono cinese	264
base per bastardella	268	coperchio	181-189-194
bastardella	268	coperchio bagnomaria quadrato	260
batticarne	292	coperchio gastronomico	239-240-252-257
bicchiere	317	coperchio teglia	224
bistecchiera	223	coperchio vetro	215
bollilatte	214	coperchio zuppiera	172
brocca termica	364	coppa gelato	334
caffettiere	341-342	crepiere	222-206
casseruola conica	178-188	cucchiaino marmellata	148
casseruola fonda	171-177-187-193-197- 207-211-217	cucchiaino servire	145-150
casseruola fonda con manico	171-178- 188-194-194-198-213	cucchiaino multiuso	148
casseruola mezza fonda - bassa	171-177-187- 193-197-212-214	cucchiaino multiuso forato	147-148
casser mezza fonda - bassa con manico	171- 178-188-194-198	cucchiaino pizzaiolo	146
cavatappi	127-292	cucchiaino risotto	144
cestino frutta	158	cucchiaino risotto forato	144
cestino pane	157-159	cucchiaino unipezzo	286-288
chaffing dishes	359-362	cuociforno	221
chiudibottiglia	328	cuocipesce	216
cloche	154-156	distributore bevande buffet	354-355
colabrodo	215	distributore succhi buffet	354-355
colapasta	214	dosatore gelato	304
colapasta a rete	265	falso fondo gastronomico	241-244-252-255
colapasta sferico	263	forbici dolce	301
colonna portasecchiello	161-162	forchetta 5 punte	144
coltello affettati	137	forchetta servire	146-150
coltello bistecca	123-133-140-142	forchettone 3 punte	146
coltello cucina	142-145	forchettone arrosto	124
coltello cucina orientale	136	forchettone insalata	146-148
coltello disossatore	137	forchettone unipezzo	288-289
coltello pane	128-143	forma creme caramel	269
		formaggera	165-166
		fruste	290
		imbuto	269
		insalatiera	267

lattiera	341	punta grana	125-141
legumiera con alette	317	raccogli briciole	292
legumiera ovale	226	ricambi	367
lumachiera	226	rompinoce	292
manaretta	136-308	sale pepe	163-164-166
mattarello	269	salsiere	156
mestolo unipezzo	286	scaldapasta forato	264
mestolo salsa unipezzo	287	scaldapasta settori	265
mezzaluna	141	scavino crostacei	125-135
molle	294-297	schiumarola unipezzo	286
morsa prosciutto	358	scodelle	317
multiuso crostacei	125-135	secchiello champagne	160-161-162
oliera	163	secchiello ghiaccio	160
padella 179-188-189-195-198-201-203-205-223		separatore	162
padella sauté	172-180-190	setacci	266
padella sauté antiaderente	180-190	shaker	323
paellera	220	sistema refrigerante buffet	356
paellera girevole	363	sottobicchiere	153
paiolo	210	sottobottiglia	153
pala fritto unipezzo	313	sottopiatto	153-154
pala lasage	123	spatola gelato	332-333
pala torta	145	spatola unipezzo	287
pala uovo	145	speedy-pasta	185
passabrodo	264	spillone porta scontrini	325
passaverdura	268	spremiagrumi	324
pentola	177-187-193-213-220	tappo champagne	328
piastra antiaderente	221	tappo vino	328
piattino cassata	334	tazza brodo	317
piattino per coppa	334	tegame	179-189-197-205-209-214
piatto affettati buffet	357-358	tegame antiaderente	181
piatto fondo	316	tegame uovo	226
piatto formaggi buffet	351	teglia gastronorm	235-249
piatto ovale	272-273	teglia gastronorm alluminio antiad.	232
piatto piano	316	teglie	224-225
piatto portapane	154	teiera	339-340
pietanziera	316	tortiera	225
pinza aragosta	125	trinciapollo	124-290
porta brocche	364	utensili cucina ellisse	302
porta burro	356-368	vassoi con scomparti	241-318
porta burro buffet	356	vassoi impilabili	345
portaghiaccio	161	vassoio gratin	273
portagrissini	158	vassoio ovale	272-273-275
portapane buffet	352	vassoio rettangolare	274-276
posate detenuti	319	vassoio rettangolare pasticceria	345

vassoio tondo	273-275
wok	206-220
wok con 1 manico	206
zuccheriera	325-341
zuppiera	280-282

ALL ITEMS AVAILABLE

3 prong fork	146	conical ice cream goblet	334
5 prong fork	144	convict spoon and fork	319
bain marie	262	cork screw	127-292
basin with retractable handles	238	creme caramel mould	267
bill spike	325	crepe frying pan	206-222
boning knife	137	cruet	163-164-165-166-267
bottle coaster	153	crumb collector	292
bottle stopper	329	deep casserole	171-177-178-187-188-193-197-209-213-219-220
bowl	325-341	deep plate	316
bread basket	352	display	324
bread coaster	154	divider	161-241-306
bread stick holder	158	drink dispenser	354
bread knife	128-143	edged oval tray	272-275
butcher's knife	136	edged plate	334
butter dish	281	egg lifter	145-303
butter tray	356-368	false perforated bottom	241-244-252-255
cake server	145-300	fillet knife	137
carving fork	128	fishkettle	216
chafing dishes	359-362	flat plate	316-319
champagne bucket	160-161-162	foot for semispheric bowl	268
champagne bucket stand	161-162	french omelet pan	226
champagne stopper	328	fruit basket	158
cheese bowl	373-371	frying pan	172-179-180-181-188-189-190-197-205-206-210
chef knife	136-137-138-142-143	frying pan 2 handles	181-190-197-205-214
chinois	264	frying pan for paella	363
citrus squeezer	324	funnel	264
cleaver	136-308	glass	317
cloche	154-156-281-282	glass lid	215
coaster	153	gratin tray	273
coffee pot	341-342	gridiron	221
colander	184		
conical casserole	179-188		

ham clamp	358	rice spoon	144
ham slicer	138	roasting pan	209-221-224-225
hotplate	321	round edged tray	273-275
ice bucket	160-162-356	round tray	154-156-275-277-344
ice cream scoop	304-332	salad bowl with handles	265
ice cream plate	334	salad fork	146-148
ice cream spatula	333	salmon knife	138
icebox	161	salt and pepper	164-166
jam/honey spoon	148	sauce boat	156-280-282
japanese cook	136	sauce ladle Unipezzo	287
jug holder	364	sautè frying pan	172-180-190
juice dispenser	354	sea food pick	135
ladle Unipezzo	286	section colander	184-186-265
lid	181-189-194	separator	162
lid for roasting pan	224	serving dish	316
lid for soup bowl	156-280-282	serving fork	146-150
lid gastronorm	237-242-250-253-255	serving fork unipezzo	289
lobster cracker	135	serving knife	144
lobster pick	135	serving spoon	145-150
low casserole	171-177-187-193-197	serving spoon unipezzo	288-289-311
meat mallet	293	shaker	323
milk pot	342	sharpener	141
milkpot	214	skimmer unipezzo	286-312
mincing knife	141	slicer knife	137-143
multipurpose spoon	150	snails plate	226
non stick frying pan 2 handles	181	saucepan	171-178-188-194-198-210-214
non stick sautè pan	180-190	soup bowl	156-280-282
non stick basin	222	soup cup	317
nutcracker	292	spatula lasagne	123-145
paellera	219-361	spatula unipezzo	287
paring knife	140-142	Speedy-Pasta	184
parmesan cheese knife	141	spherical colander	263
pastry deep tray	345-346	square lid	262
peeling knife	140-142	spare parts	371-372-374-375
perforated rice spoon	144	stackable basin	231
perforated spatula Unipezzo	287-289	steak knife	123-135-140-142
perforated spoon	147	strainer	264-266-302-322
perforated stackable basin	235-236-250	sugar bowl	325-341
pitcher	364	tea pot	341-342
pot	177-184-185-186-187-193	tomato spoon	146
poultry shears	290	tong	294-296-298
pressure cooker	374	tray for cheese buffet	351
rectangula tray	274-278	tray with sector	241-318
refrigerating brick	369	underplate	153-157

utensils ellisse	302
vegetable dish	226-317
vegetable dish with handles	317
vegetable mill	268
wall tray for sliced	357
warmer	363
whisk	290-303
wine stopper	328
wok	206-220

PINTINOX

MADE IN ITALY

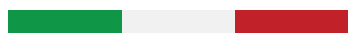

HORECA
2018